

*Eastwood*

DO THE JOB RIGHT.

Part #13574

# 8", 3/4 HP BENCH GRINDER INSTRUCTIONS



**THE EASTWOOD 8", 3/4 HP GRINDER** is a powerful, heavy-duty, high-quality shop tool precision engineered to provide excellent performance, rugged reliability and long life. It is equipped with a convenient flexible stem work lamp and sturdy tool rests.

## WARNINGS

- Be Sure to **BECOME FAMILIAR** with all aspects of grinding wheel operation before using. Objects can be violently propelled by the wheel at high speed causing serious injury or death.
- **DO NOT** attempt to operate without guards, shields and guides in place! Serious injury could result!
- **DO NOT** attempt to operate without base being securely and firmly attached to a solid work surface. Serious injury could result.
- **IMPORTANT NOTE:** Grinding creates hot sparks and metal fragments which are ejected from the wheel at a considerable distance.
  - Keep flammable materials and liquids away from the grinding area.
  - Use appropriate ANSI or CSA approved eye and face protection.
  - Keep people and pets away from the grinding area.
- Keep long sleeves, other loose clothing and long hair away from rotating wheels. Serious injury could result.
- Keep fingers and hands away from rotating wheels. Use locking pliers or other suitable device to firmly hold smaller items while grinding.
- Should grinding wheels become cracked or an unbalanced condition or vibration develops, **TURN OFF SWITCH** and **STOP USE IMMEDIATELY!**

## SPECIFICATIONS

- 120V AC/60Hz.
- 3/4 Horsepower Motor
- 5/8" Shaft Diameter.
- 3450 RPM
- 8" x 1" Grinding Wheels. Left = 36 Grit, Right = 60 Grit
- Flexible Stem, 40 watt work lamp. (Bulb not included).

## ASSEMBLY AND SET-UP

- Remove Grinder, parts bags and hardware from packaging. Be careful not to discard parts bags with packaging.
- Attach left and right Tool Rests to lower edge of wheel guard opening with supplied knob screws, washers and lock washers (Fig A). Locate slot over pin and adjust so that rear edge of tool rest is 1/8" from wheel surface.
- Attach left and right Spark Deflectors over upper edge of wheel guard opening with supplied screws, washers and lock washers (Fig B). Keeping the bottom edge approx 1/16" from the wheel surface.
- Attach Eye Shields to left and right curved mounting arms with supplied thumb screws, washers and lock washers (Fig C).
- Assemble Eye Shield assemblies to holes at the inboard, 12:00 position of the Wheel Guards with supplied long hex head bolts, washers and lock washers (Fig C).
- Snap the coolant-tray into the brackets located on the base. Fill with clean water.
- Place a 40 watt maximum bulb in the work lamp socket. Note: a vibration resistant or appliance bulb works best.

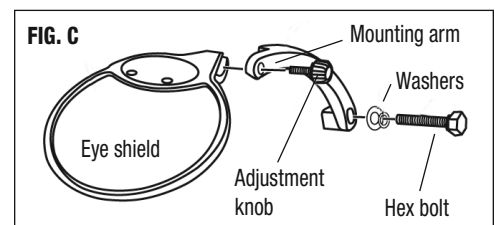
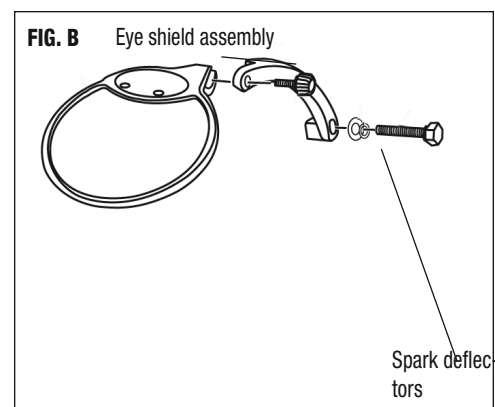
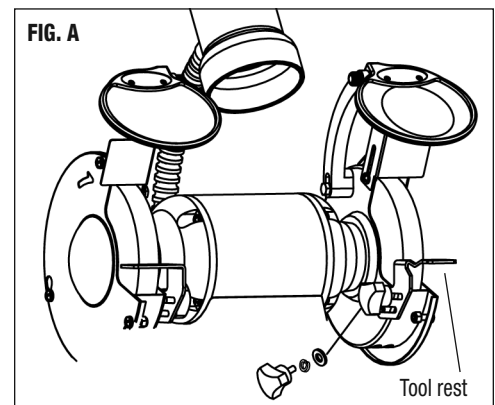

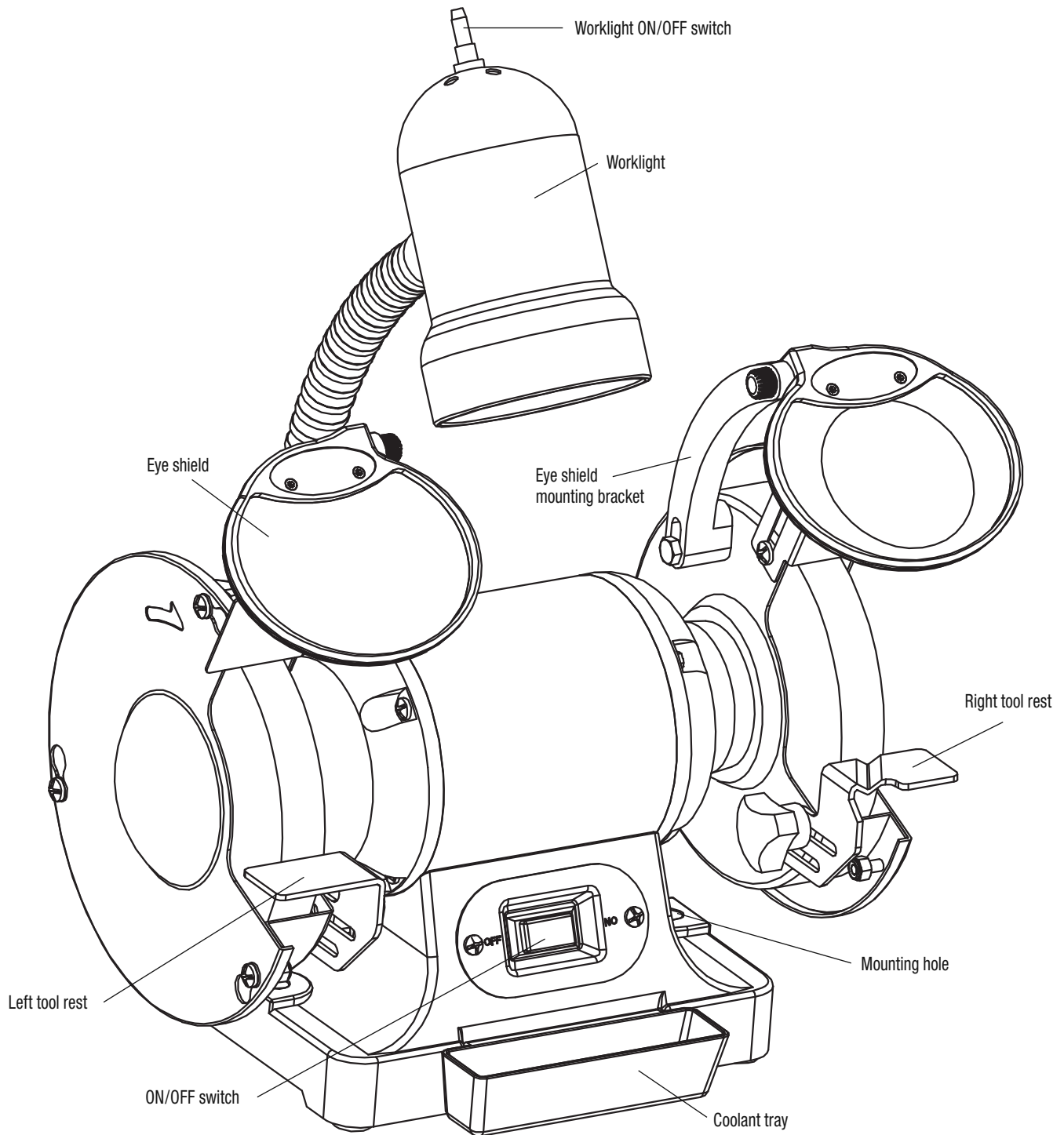

## OPERATION

- The grinder **MUST** be securely bolted or clamped to a solid work surface at a comfortable working height.
- Make sure the switch is in the **OFF** position before plugging in.
- Stand to one side and turn switch on then allow motor to reach operating speed. Check for vibration and shut-off immediately if any vibration is detected.
- **VERY IMPORTANT!** The wheel rotates in a Counter-Clockwise direction when viewed from the right side. When viewed from the front, the top segment of the wheel exposed by the shield is rotating toward the operator. **ALWAYS** grind objects pointing slightly downward and **NEVER** upward as they can be violently hurled toward you causing severe injury or death!
- Only apply a very light pressure against the wheel when grinding. **NEVER** push an object hard against a grinding wheel.
- Always use the tool rests for support and stabilization.
- Only allow the object being ground to contact the wheel for several seconds at a time. Heat will quickly build in the wheel and ground object which can cause damage and burns. Dip the object into the coolant in the tray as required.
- **NEVER** grind against the side of the wheel as an imbalance condition or even cracking can occur.

# TROUBLESHOOTING

- **Motor will not start when switch is turned on:**
  - Check 120 VAC input plug connection.
  - Check for binding of shielding, tool rests or guards against wheel.
- **Motor slows down while operating:**
  - Too much pressure being applied to the wheel. Reduce pressure.
  - Check for binding of shielding, tool rests or guards against wheel.
- **Burned appearance on ground object:**
  - Too much pressure being applied to the wheel. Reduce pressure.
  - Ground object being held too long against wheel. Grind several seconds on, wait several seconds, re-grind.
  - Dip ground object into coolant.
- **Wheel wearing rapidly:**
  - Too much pressure being applied to the wheel. Reduce pressure.
  - Wheel too soft for material being ground, use harder wheel.
  - Ground object being held too long against wheel. Grind several seconds on, wait several seconds, re-grind.
- **Wheel loading up with metal:**
  - Too much pressure being applied to the wheel. Reduce pressure.
  - Wheel too hard for material being ground, use softer wheel.
  - Ground object being held too long against wheel. Grind several seconds on, wait several seconds, re-grind.
  - Too much heat in ground object. Dip into coolant.

# REPLACING A WHEEL

Your grinder's unique quick-release covers make wheel replacement a snap.

- Make sure the grinder is **OFF** and **UNPLUGGED!**
- Loosen the three Phillips head screws (don't remove) and rotate the side plate of the wheel guard along the slots counter-clockwise (left side) or clockwise (right side) until the holes clear the screw heads (Fig D). Set aside.
- Remove large retaining nut (Clockwise, reverse thread for the left side shaft and Counter-clockwise standard thread for the right side shaft) (Fig D).
- Remove Outer Flange Washer.
- Remove Grinding Wheel.
- Replace in reverse order of disassembly. Be aware that the left side shaft is reverse threaded. **NOTE:** Do not over-tighten the Grinding Wheel Retaining Nut. Cracking of the Grinding Wheel could occur resulting in a dangerous condition.

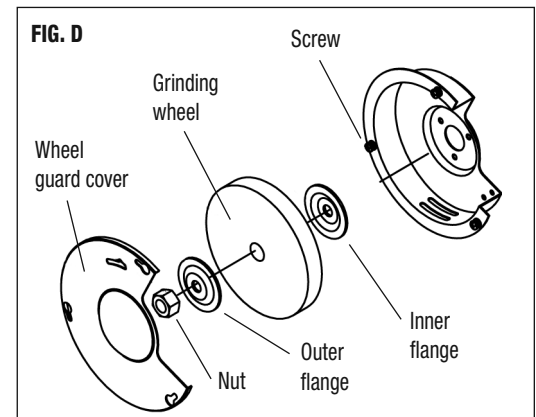

**If you have any questions about the use of this product, please contact**

The Eastwood Technical Assistance Service Department: 800.544.5118 >> email: [techhelp@eastwood.com](mailto:techhelp@eastwood.com)

The Eastwood Company 263 Shoemaker Road, Pottstown, PA 19464, USA

US and Canada: 800.345.1178 outside US: 610.718.8335

Fax: 610.323.6268 [eastwood.com](http://eastwood.com)