

Eastwood

DO THE JOB RIGHT.

Part #13689

PLASMA CUTTING GUIDE

INSTRUCTIONS



The **EASTWOOD PLASMA CUTTING GUIDE** was specifically designed to fit the **Eastwood Versa Cut Plasma Cutter**. This cutting guide will also work on other torches with a 0.95" (24mm) Nozzle. It allows for easy cutting of straight lines, curves, radii, and circles.

WARNINGS

- Read Plasma Cutter's Instruction Manual before attempting to use.
- DO NOT use without protective gloves, and long sleeve shirt or jacket.
- Protect lower legs and feet when using plasma cutter from heavy slag and sparks.
- Always use a minimum Shade 5 lens for eye protection.

SET-UP AND OPERATION

ATTACHMENT TO TORCH

1. Turn OFF and unplug Plasma Cutter before proceeding.
2. Determine the top and bottom of the plasma cutter guide by referring to Fig. 1.
3. Insert the torch into the cutting guide and tighten the 2.5mm set screw to secure the cutting guide to the torch.



STRAIGHT LINE CUTTING

1. To configure the Eastwood Plasma Cutting Guide for Straight Line cutting, remove the rod assembly from the Cutting Guide.
 2. Install the cutting guide onto the torch as shown in Fig. 2.
- NOTE:** If the nozzle of the torch is hitting the work piece, the cutting guide is installed upside down.
3. Align the wheels and torch in the direction you would like to make the cut and lock the Cutting Guide from rotating by tightening the set screw with a 2mm Allen wrench.



4. Measure and mark your material with a permanent or metal marker. This should be easy to see so that it can be followed during the cutting process.
5. Line up your nozzle on the torch with your markings and begin cutting by rolling the cutting guide across the surface. It is best to look where you're heading while cutting rather than directly in front of the cutting guide to achieve the straightest line possible.

CIRCLES AND RADII

1. To configure the Eastwood Plasma Cutting Guide for Circles and radii cutting, install the rod along with the center point mount (Fig. 3). Tighten the rod by threading into the cutting guide and then secure by tightening the jam nut.
2. Determine the center point of your arc or circle and mark the piece of metal.
3. There are 2 ways to mount the cutting guide to the center point:
 - a. Use a center punch and mark the center point of the arc and place the tapered point of the center point mount into the punch mark.
 - b. Drill a 3/16" hole at the center point. Remove the thumb screw in the center point mount and install through the metal being cut. Make sure to put the spring on the underside of the piece being cut to keep tension on the center point mount.
4. Once the cutting guide is centered, make a practice pass with the torch to determine the best starting point of the cut. It is ideal to make the cut in one smooth motion without stopping the cut; determine the best starting point to achieve this.
5. Once a starting point has been determined, the cut can be made; your speed of travel will depend on your output Amp setting as well as your material thickness.
6. When finished making the cut of the arc or circle the piece will either fall out or still be attached to the cutting guide depending on the center mounting method used.

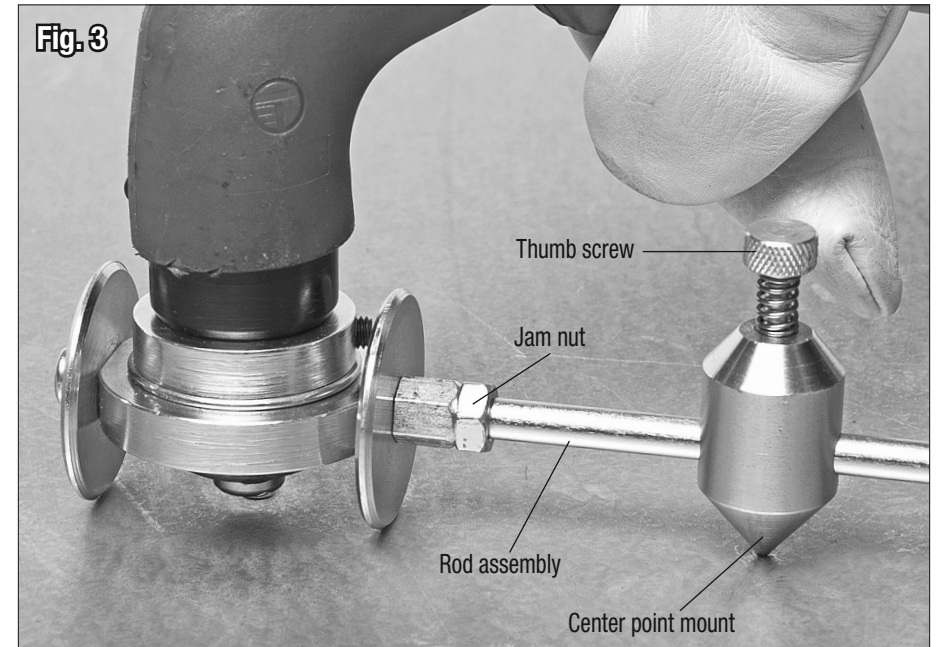

TROUBLESHOOTING

- Nozzle on torch contacts surface prohibiting the wheels on the guide from touching the surface
 - Remove the cutting guide and flip the guide over and reinstall.
- Torch does not completely cut through metal
 - Increase Amp output.
 - Increase Air Pressure but do not exceed 60psi.
 - Decrease travel speed of torch.

If you have any questions about the use of this product, please contact

The Eastwood Technical Assistance Service Department:
800.544.5118 >> email: techelp@eastwood.com

The Eastwood Company 263 Shoemaker Road, Pottstown, PA 19464, USA
US and Canada: 800.345.1178 outside US: 610.718.8335
Fax: 610.323.6268 eastwood.com