

Eastwood[®]

DO THE JOB RIGHT.[®]

Item #15639

CONCOURS[®] LT100 HVLP PAINT GUN INSTRUCTIONS



The **EASTWOOD CONCOURS®LT100 HVLP PAINT GUN** has all the features of a professional paint gun with the added benefit of a specific, low air demand design requiring only 4.5 CFM [120 l/min] @ 30 PSI [2 Bar]. It is precision engineered, capable of producing a high-quality paint finish and ideal for the seasoned professional or hobbyist. The body is constructed of a highly durable diecast alloy with Stainless Steel internal components which are compatible with both solvent and waterborne coatings. Convenient reference markings on the gun body and control knobs allow for accurate repeatability of gun settings.

CONTENTS

- (1) HVLP Paint Gun
with 1.3mm stainless steel
nozzle/needle set installed
- (1) 600ml., solvent resistant,
composite Paint Cup
- (1) Paint Cup Inlet Filter
- (1) Paint Gun Wrench
- (1) Round Cleaning Brush
- (1) Rectangular Cleaning Brush



SPECIFICATIONS

- Requires 4.5 CFM [120 l/min] @ 30 PSI [2 Bar]
- 1/4" male NPT air input threads
- M16 x 1.5 NPS paint cup inlet attachment threads
- 1.3 mm stainless steel needle/nozzle set installed (others available)

SAFETY INFORMATION

The following explanations are displayed in this manual, on the labeling, and on all other information provided with this product:

DANGER

DANGER indicates a hazardous situation which, if not avoided, will result in death or serious injury.

WARNING

WARNING indicates a hazardous situation which, if not avoided, could result in death or serious injury.

CAUTION

CAUTION used with the safety alert symbol, indicates a hazardous situation which, if not avoided, could result in minor or moderate injury.

NOTICE

NOTICE is used to address practices not related to personal injury.

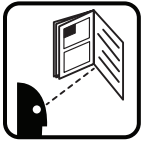

READ INSTRUCTIONS

- Thoroughly read and understand these product instructions before using this equipment. Failure to follow all warnings can result in tool damage or serious physical injury.
- Keep these product instructions for future reference.



WARNING FIRE AND EXPLOSION HAZARD!

- Do Not use near sparks, open flame or another potential ignition source. Solvents and paints are highly combustible and may ignite or explode. Keep at least 25' away from any non-explosion proof compressors, motors, switches etc.



WARNING HEALTH HAZARD!

- Avoid breathing vapors produced by Spray Gun. Always wear appropriate NIOSH approved breathing apparatus and use in a well-ventilated area.
- Wear appropriate ANSI standard Z87.1 eye protection.
- Wear solvent-resistant gloves.
- Do not allow unprotected persons or pets in the spray area.



CAUTION BURSTING HAZARD!

- Do not exceed 60 psi (4.1 bar) of air inlet pressure. Permanent paint gun damage and/or bursting could occur and cause personal injury.

SAFETY INFORMATION



⚠ CAUTION INJURY HAZARD!

- This Paint Gun can accidentally spray when handling while connected to an air supply causing serious personal injury. Always disconnect the Paint Gun from the air supply before adding paint, changing nozzles, removing clogs or other maintenance.

⚠ NOTICE

- Use only Eastwood Aerosol Injected Cleaner, Eastwood Paint Gun and Equipment Cleaner, acetone or lacquer thinner to clean guns. Use of chlorinated or halogenated hydrocarbon solvents can corrode aluminum gun components or emit hazardous reactive gasses.
- Use for spraying paint products only. Do not use for spraying pesticides, fertilizer, acids or other corrosive materials and solvents.

SET-UP

- Remove all components from carton, identify them and become familiar with their purpose.
- Before use, it is necessary to thoroughly clean out the paint cup as well as the paint gun air and paint passages with a solvent such as Eastwood PRE, Eastwood Aerosol Injected Cleaner, Eastwood Paint Gun and Equipment Cleaner or acetone. This is to remove any residual manufacturing oils or impurities that may remain. Dry thoroughly.
- A 3/8" I.D. minimum air hose at a 25' maximum length is strongly recommended for best results. Smaller I.D. hose and greater length may reduce available CFM and produce unsatisfactory results.
- A clean, dry, regulated air supply is required. An Eastwood #31633, Eastwood Air CFS, or equivalent works well.
- To avoid pulsation of pressure when the trigger is depressed, an optionally available, remotely mounted, main regulator should be set to approx. 40 PSI [2.75 bar] and an optional "on the gun" regulator (an Eastwood #31834 Concours Pro Regulator works perfectly), initially set to 30 PSI [2 bar], is then used for fine-tuning of gun pressure.

ASSEMBLY

- Insert the Paint Cup Inlet Filter into the inlet at the top of the Gun Body (**FIG 1**).
- Thread the Gun Cup onto the threaded inlet at the top of the Gun Body. Hand Tighten only (**FIG 2**).
- The Paint Gun is now ready for use.

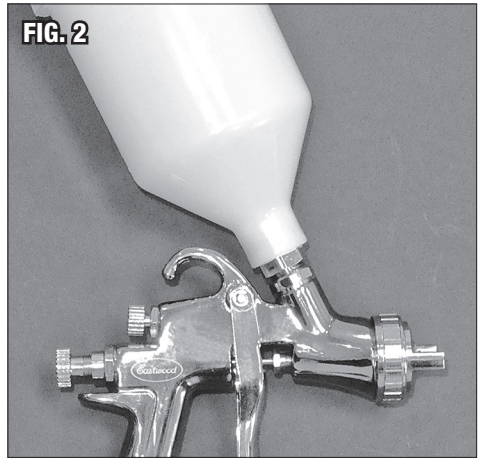

IMPORTANT NOTES BEFORE PAINTING

1. Please note that many variables affect the adjustment of a paint gun including paint viscosity and type, atmospheric conditions such as humidity, barometric pressure and temperature, as well as air inlet pressure and operator preference. Always “tune” the gun before each use as prevailing conditions may not be the same as the previous use.
2. It is always best to test spray on sheets of cardboard or masking paper with the actual paint you will be applying while making your adjustments to become familiar with the gun and achieve the ideal Fluid Control Setting.
3. Remember that a small amount of product wasted at this point can avoid disappointment in your results and the need to re-do your work later.

GUN SETTINGS

FIG. 3

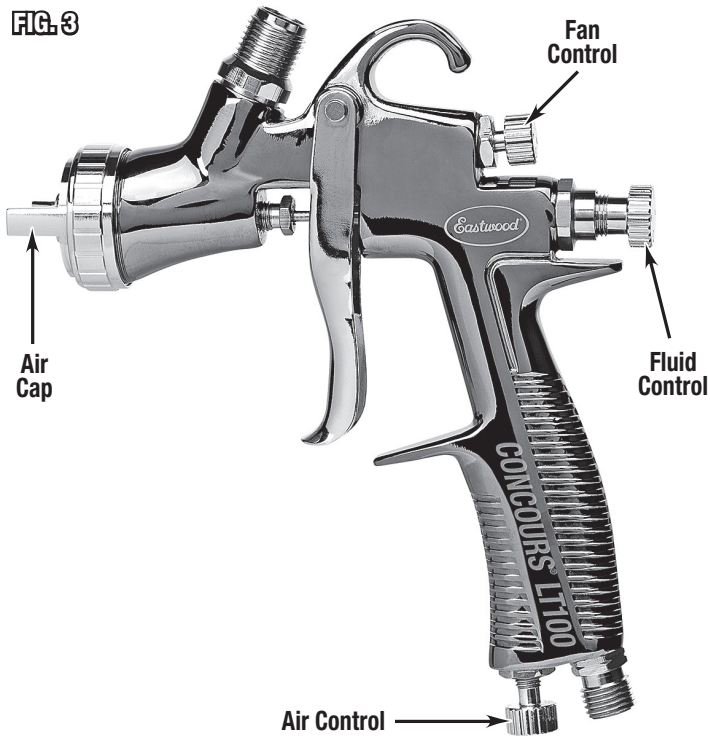

- **Air Cap** - Make sure the Air Cap is properly oriented in a horizontal plane to produce a vertical fan spray pattern by viewing the HVLV Paint Gun from the front. To adjust, loosen Retaining Ring by rotating counter-clockwise slightly, adjust Air Cap then re-tighten Retaining Ring (FIG 3).
- **Fluid Control** – The Fluid Control knob (located at mid-rear of gun body) regulates the distance the Needle travels and the amount of paint flowing through the gun. **NOTE:** Generally, for higher viscosity coatings, a wider opening is desired while a closer opening is better suited for lower viscosity fluids. To adjust, rotate the Fluid Control Knob outward (counter-clockwise as viewed from the rear) to increase flow and turn inward to reduce flow (FIG 3).
- **Fan Control** – The Fan Control knob (located at the upper-rear of the paint gun body) controls the size and shape of the spray pattern of “fan”. Rotating the knob counter-clockwise (as viewed from the rear of the gun) will produce a larger and softer spray pattern while rotating it clockwise will result in a smaller, sharper, round pattern. For most painting conditions, a larger, softer fan is desired (FIG 3).

- **Air Control** – The Air Control knob (located at the bottom of the gun handle adjacent to the air inlet) is opened by rotating in a counter-clockwise direction (as viewed from the bottom of the gun). This is for “fine tuning” the airflow to the gun. You will generally want to set the inlet pressure at the regulator, start with the Air Control in the fully open position and decrease air as needed (**FIG 3**).
- With practice, you will quickly acquire a “feel” for the gun and will be producing professional results.
- After achieving optimal knob settings, note their positions with the numbered indicators on the face of the knobs. This will assist in quickly “tuning” the gun in future uses (**FIG 4**).

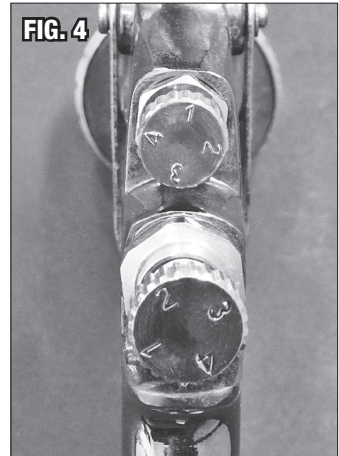

GUN CLEAN-UP

- Disconnect air supply to gun.
- Pour unused coating into a proper disposal container, then remove Paint Cup.
- Wipe out any excess coating then thoroughly rinse the Paint Cup with a mild solvent compatible with the coating being used.
- Attach Paint Cup, then pour a small amount of a solvent compatible with the paint being used into the Cup, then run solvent through HVLP Gun in a safe area until it flows clear.

⚠ NOTICE

As an alternative, #12846Z Eastwood Aerosol Injected Gun Cleaner and #16154ZP Eastwood Paint Gun and Equipment Cleaner are excellent for this purpose.

- Remove air supply from HVLP Gun.
- Pour out any unused solvent and remove paint cup.
- Allow solvent to dry completely from all components.

PAIN T GUN DISASSEMBLY FOR ADDITIONAL CLEANING

- Remove Air Cap by unthreading and removing the chrome Retaining Ring.
- Remove Nozzle with the 19mm hex of the wrench (included) (FIG 5).
- Unthread and remove Fluid Control Knob from rear of Paint Gun body (FIG 6).
- Carefully remove Tension Coil Spring with Bushing and Needle by firmly gripping rear of Needle and pulling out through rear of Paint Gun body (FIG 7).

REASSEMBLY

- Replace Needle by sliding into bore in rear of Paint Gun body until it seats.
- Slide Needle Tension Spring w/bushing over the rear of the Needle.
- Replace Nozzle by threading into front of Gun Body and tighten firmly with the 19mm hex of the included wrench (do not-over tighten).
- Replace Air cap by threading Retaining Ring onto Gun Body. Make sure the air horns of the Air Cap are oriented properly.

FIG. 5



FIG. 6

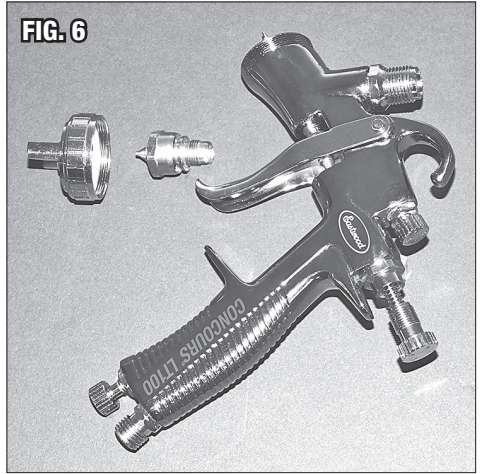
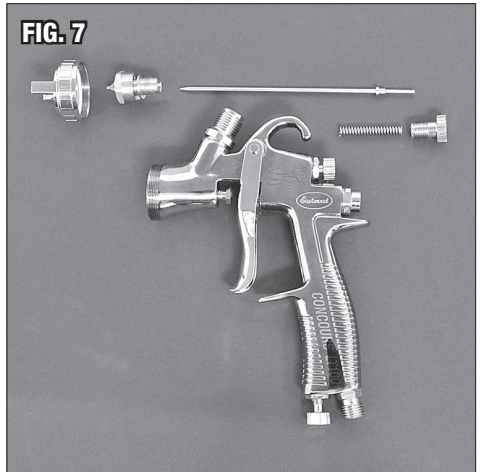

FIG. 7



TROUBLESHOOTING

PROBLEM	CAUSE	CORRECTION
Gun Produces an Uneven Spray Pattern or Fan	Paint or film buildup on Air Cap blocking air holes	Disconnect air supply and clean buildup from Air Cap.
Gun “Spits” or Sputters; Discharges Large Droplets	Paint or film buildup on Needle & Nozzle	Disconnect air supply and clean buildup from Needle & Nozzle. NOTE: Use of solvent may be helpful, removal of the Nozzle may be necessary.
Gun Dispenses Only a Small Amount of Paint or None at All	Clump or piece of paint film blocking paint inlet port	Disconnect air supply; remove paint cup, remove blockage from paint inlet area then strain paint or coating to remove clumps or film.
Heavy Textured or “Orange Peel” Paint Appearance	Paint Gun is too close to surface	Keep within 8” to 12”.
	Inlet air pressure too low	Increase inlet air pressure and or decrease fluid flow.
	Incorrect thinner/reducer	Check paint manufacturer’s reducing/thinning instructions.
	Incorrect material mix ratios	Check paint manufacturer’s mix ratio instructions.
Excessive Runs and Sags	Paint Gun being moved too slowly over surface	Speed up gun motion over surface.
	Excessive fluid flow	Decrease fluid flow by adjusting “fluid” knob.
	Paint mixed too thin	Check paint manufacturer’s reducing/thinning instructions.

TROUBLESHOOTING

PROBLEM	CAUSE	CORRECTION
“Dry” Paint Appearance	Paint Gun is too far from surface.	Keep within 8” to 12”.
	Paint Gun being moved too fast over surface.	Slow down gun motion over surface.
	Inlet air pressure too high.	Decrease gun inlet air pressure and or increase fluid flow.
	Incorrect thinner/reducer.	Check paint manufacturer’s reducing/thinning instructions.
Thin Paint Appearance	Paint Gun is too far from surface.	Keep within 8” to 12”.
	Paint Gun being moved too fast over surface.	Slow down gun motion over surface.
	Inlet air pressure too high.	Decrease gun inlet air pressure and or increase fluid flow.
	Incorrect thinner/reducer.	Check paint manufacturer’s reducing/thinning instructions.
Paint Spray is Sputtering	Paint Gun is dirty or contaminated.	Disassemble and clean gun with suitable solvent.
	Nozzle or Air cap loose.	Tighten Nozzle and or Air Cap.
	Needle tip or Nozzle seat damaged.	Replace Needle/Nozzle set.
	Gun being tipped too far down.	Operate gun with tip tilted no more than 45° down or up.

TROUBLESHOOTING

PROBLEM	CAUSE	CORRECTION
Gun “Sprts” at Initial Trigger Pull Then Evens Out	No main air regulator in line causing pressure build up in air line.	A main remote regulator must be installed air supply line and set to 40 PSI [2.76 bar].
	Air regulator set too far back in line causing pressure build up in air line.	Install an “On Gun” regulator at inlet of paint gun.
“Dogbone” Shaped Spray Pattern	Inlet air pressure too high.	Decrease inlet air pressure at gun.
	Fluid flow adjusted too low.	Increase fluid flow adjustment on gun.
Exaggerated “Football” Shaped Spray Pattern	Inlet air pressure too low.	Increase inlet air pressure at gun.
	Fluid flow adjusted too high.	Decrease fluid flow adjustment on gun.
	Paint mixture too thick.	Check paint manufacturer’s mix ratio instructions or thin if possible.

ADDITIONAL ITEMS

#31633	Eastwood Air CFS Complete Air Filter Regulator
#31834	Concours Pro “On Gun” Regulator
#10041Z	Eastwood PRE-Painting Prep, Aerosol
#12846Z	Aerosol Injected Paint Gun Cleaner
#16154ZP	Eastwood Paint Gun and Equipment Cleaner
#16186	Eastwood Professional Paint Gun Cleaning Set
#14829	Gerson One Step P95 Respirator
#20405 & 20406	Gen-Nex Painters Coveralls
#50207	DeVillbiss DeKups # DPC-11 Adapter
#31624Z	Kresto Hand Cleaner, 200ml Tube
#31625	Kresto Cherry Scrubbing Wipes

If you have any questions about the use of this product, please contact

The Eastwood Technical Assistance Service Department: 800.343.9353 >> email: tech@eastwood.com

PDF version of this manual is available at eastwood.com

The Eastwood Company 263 Shoemaker Road, Pottstown, PA 19464, USA

800.343.9353 eastwood.com