



263 SHOEMAKER RD. POTTSTOWN, PA 19464
1-800-345-1178 INTERNATIONAL: 610-323-2200
FAX: 610-323-6268
WWW.EASTWOOD.COM

Instruction Manual Part #19031Q – Rev. 1/06

Eastwood Stitch Welder

Part #19031



The Eastwood Stitch Welder attaches to any conventional A/C unit arc (stick) welder permitting welding on sheet metal as thin as 22 gauge. Welding with the Stitch Welder is faster and easier than conventional stick welding with less chance of burning through or warping sheet metal.

Operating Instructions

Using Your Stitch Welder

IMPORTANT SAFETY NOTICE

Important: Repair procedures and techniques, tools and parts for servicing motor vehicles, as well as the skill and experience of the individual performing the work vary widely. It is not possible to anticipate all the conceivable ways or conditions under which a vehicle may be serviced or repaired, or to provide cautions as to all of the possible hazards that may result. Standard and accepted safety precautions and equipment should be used during cutting, grinding, chiseling, chipping, prying or any other process that can cause material removal or projectiles. Proper safety clothes and precautions including eye protection must be worn when welding. Before performing any operation, you must be completely satisfied that neither your personal safety nor the condition, performance or value of the vehicle will be endangered.

Your new Eastwood Stitch Welder consists of a one-piece metal body including the Power Head containing a special solenoid, insulated handle and the power cord. The solenoid is the key to the Stitch Welder's operation. The solenoid moves the welding rod in and out, just a fraction of an inch, very rapidly. You probably won't even notice the movement.

The unique stitching action makes and breaks the electric contact at the end of the welding rod, making it easy to start and maintain the arc.

Welding rods 1/16" diameter work best. Always use a "non-aggressive" welding rod. Electrodes classified as type 6010 or 6011 are too harsh. Mild steel rods such as type 6013 and 7014 produce the spraying arc that works best on light metal. We suggest using Eastwood's special Stitch Welder rods (#19001, 1/16"). They feature a high quality flux coating that helps produce fine welds.

When the electrode is touched to the workpiece, the electrical circuit is completed.

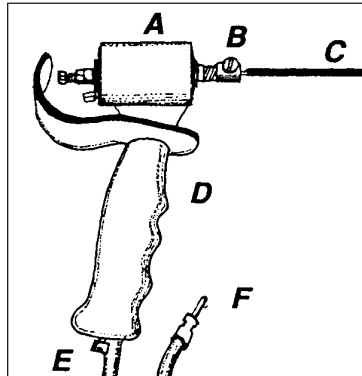

- A. Power Head
- B. Electrode Collar (Carrier)
- C. Electrode
- D. Insulate Handle
- E. Diode Adjuster Screw
- F. Power Lead



Setup begins by inserting an electrode into the Stitch Welder's brass collar, and snug up the set screw.

The Eastwood Stitch Welder

By touching the electrode briefly to the work, then lifting it slightly, electric current jumps the gap forming an electric arc. Striking an arc is usually a real challenge for a beginning welder, especially when using low amperage as required for automotive sheet metal work.

The tremendous heat of the arc melts a puddle in the workpiece and also melts the welding rod. The metal rod core flows into and fills the puddles as you move the arc along the joint.

Melted metal wants to combine with oxygen in the air, weakening the joint. The coating on the welding rod is made so it melts and forms a "slag" that shields the weld bead. It also keeps the bead from cooling too rapidly causing cracks. After the weld finally cools, the slag can be chipped away.

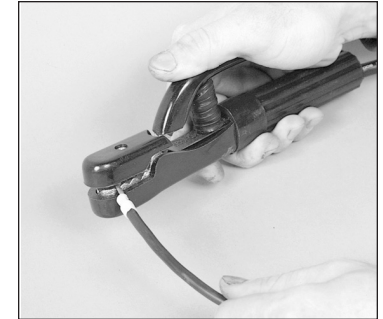

Hook up to your arc welder is very simple. Just insert the pin end of the Stitch Welder's power cord into the jaws of your welder's electrode holder. Hook your welder's ground clamp to the work as usual.

Adjusting for Proper Amperage

Your goal in welding is to get enough heat concentrated to melt the metal. Many steels found in the home restoration garage melt in the 2700°-2800°F range.

The electric arc generated by the welder can be as hot as 7,000°-10,000°F. The very high temperature of the electric arc melts the workpiece to form a "puddle" and also melts the electrode to provide metal for fill. When arc welding, it is important to use the right equipment and proper technique as the high temperature can also burn through the piece you're trying to repair.

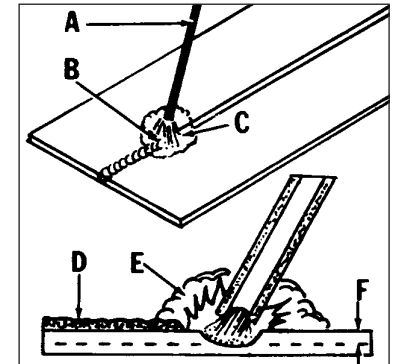

A. Welding Rod, also called the **electrode** or **stick**, supports the electric arc and produces filler for the joint. **B. Pool of melted metal** at bottom of arc. **C. Electric arc** crosses gap between electrode and work, producing intense heat. **D. Slag** build up protects weld bead. **E. Gas shield** is formed by melting flux coating, protecting the molten pool from oxygen and nitrogen in the air which will contaminate the weld. **F. Penetration depth** depends on heat and speed of movement.

Depending on your brand of welder, you may not be able to set your welder low enough to successfully weld sheet metal (40-50 amps). The Stitch Welder contains a Diode built into the handle. It will cut the current coming into the Stitch Welder, from your arc welder, in half.

The Eastwood Stitch Welder

For example, if your welder can only be set as low as 80 amps, the diode can reduce that to 40 amps – just right for welding autobody sheet metal. If your welder can be set at 40 to 50 amps, you might not need to engage the diode. Much depends on the thickness of the metal. Whether or not you need to engage the diode depends on the arc welder and its output and the thickness of the metal you are welding.

The brass screw in the base of the handle is the On/Off control for the diode. It isn't a variable control, but an on-off control only. We suggest that you experiment and practice on scrap metal to get the feel of the tool.

Try welding with the diode screw turned all the way in. With the brass screw turned all the way in, the diode is bypassed. Whatever amperage output you select on your main welder is passed through to the stitch welder. (Example: 60 amp on welder is 60 amp through Stitch Welder.) If this setting proves "too hot", simply adjust the brass screw outward, and the diode will cut the incoming current in half.

Different cars have different gauges and different strengths of sheet metal, so it's smart to practice with the equipment and the same type of metal you'll be using.

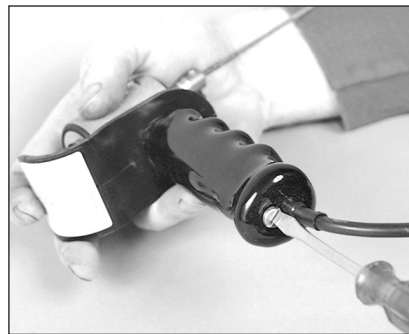
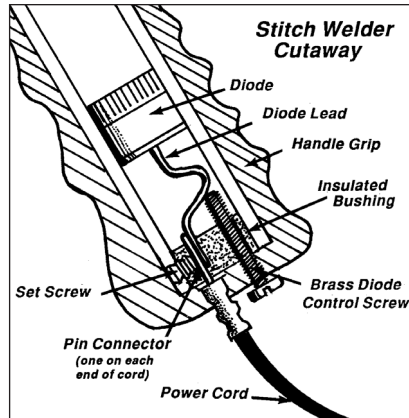

The diode control screw is located in the base of the handle. This screw is not an adjustment, but an On/Off control. It contacts a wire lead running from the diode that's built into the handle to the power cord. Whether you'll need the diode On or Off depends on how low an amperage you can set your main arc welder.

The Eastwood Stitch Welder

IMPORTANT SAFETY NOTICE

- **Welding produces sparks, smoke and fumes. Use enough ventilation to keep fumes and gases away from where you're working.**
- **Parts that are painted or plated can release toxic fumes when welded.**
- **Wear an arc welder's helmet. It has a special lens to protect your eyes and face. Eastwood carries a wide variety of suitable welding helmets. Don't use gas welding goggles.**
- **Protect yourself from welding spatter. Good leather gloves (#19010) are a must. Fully buttoned, long sleeve work shirts help protect your arms from burns. Leather work boots can keep welding spatter from giving you a "hot foot". A leather welder's apron (#19009) is a good investment if you do a lot of welding.**
- **When welding on a car, disconnect the battery. Many shops also disconnect the alternator wiring feeling this protects the unit from electrical surges.**
- **Always ground as close as possible to the work. If you ground in the wrong location, you force the current to find its own path. This path could be through parts that can be damaged.**
- **Use common sense when making hookups.**
- **Double check that there's no upholstery, carpeting, undercoating, rustproofing compound or other material behind where you're welding that could catch fire.**
- **Always work in a clean, dry place.**
- **Remember that many items in auto restoration don't mix with welding. Gasoline, lacquer thinner and other solvents and all flammable substances should be kept well away from your welding area.**

How To Strike An Arc

Eastwood's low amperage Stitch Welder does well on the material for which it was designed – automobile sheet metal body panels. Thin, 1/16" Stitch Welder Rods help you lay a quality weld bead without burn-through, when properly used.

Probably the biggest challenge is just Striking the Arc. Since there is only a limited amount of power available to jump the arc, good techniques are needed. If the rod is moved too slowly, it will stick to the work. Too quickly and you'll fail to make an arc.

Here are a few suggestions:

1. TILT THE ROD TO ABOUT 20-25 DEGREES FROM THE WORK AND SCRATCH THE SURFACE WITH THE ROD TIP, JUST AS IF YOU WERE STRIKING A MATCH.

The moment a spark is made, lift the rod quickly to a distance equal to the diameter of the rod (about 1/16"). Keep the arc going by maintaining this distance and, as you run the bead, remember to keep feeding more rod into the work.

2. ANOTHER METHOD IS TO TAP THE WORKPIECE WITH THE TIP OF THE WELDING ROD ALMOST AS IF YOU WERE TAPPING IN A NAIL.

Once the rod sparks, lift to establish the arc.

3. ANOTHER WAY IS TO HOLD THE ROD STRAIGHT UP AND DOWN IN RELATION TO THE WORK.

Lower the rod to within about an inch of the work. The rod is still too high to complete the circuit. Once you're comfortable with this position, dip the rod gently to the work and immediately raise again to establish the arc.

4. ANOTHER WAY THAT WORKS WELL, DEPENDING ON HOW THE WORK IS ARRANGED, IS TO LAY THE SIDE OF THE ROD AGAINST THE EDGE OF THE WORK.

In other words, the rod is completely off the work, only its insulated coating is touching the work. Now gently drag the rod up and onto the work. Usually the arc starts right at the edge of the work and you can continue the bead with no problems.

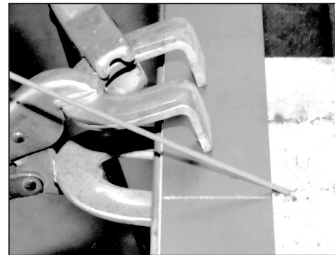

Drag the rod tip onto the work surface and you should have no trouble getting an arc started.

5. A FIFTH METHOD AND A GOOD ONE FOR BEGINNERS JUST GETTING OVER THE "ARC WELDER'S JITTERS" IS TO LAY THE ROD AT A VERY SHALLOW ANGLE, AND DRAG THE ROD A FEW INCHES.

The rod should make sparks and, with practice, you can make the transition to an arc.

How To Strike An Arc

TECH TIP: *Sometimes it pays to have a piece of scrap metal (welders call this a "Scratch Pad") right next to the piece of sheet metal you are practicing on (make sure it's grounded, too). You can even clamp this scratch pad on the car.*

By dragging the rod and starting the arc on the scrap, you can bring the arc onto the workpiece without excessive burn marks from attempts at starting the arc.

Continue to practice on scrap metal until you feel comfortable with the Stitch Welder.

How To Lay A Bead

Now that we have an idea of the basics, let's try to "lay a bead".

1. MAKE SURE YOUR STITCH WELDER IS PROPERLY HOOKED UP.
(As shown on page 3.)

2. USE SOME SCRAP FOR A PRACTICE PIECE. AN OLD PIECE OF CLEANED UP BODY METAL WORKS JUST FINE.
Clamp the workpiece firmly to a non-flammable surface.
Hook up your ground connection.

3. PUT ON YOUR WELDER'S HELMET AND RAISE THE HOOD OR LENS COVER, SO YOU CAN STILL SEE.

4. INSERT A FRESH ELECTRODE IN THE STITCH WELDER AND SNUG UP THE SET SCREW.

Hold the electrode tip about an inch or so above the workpiece. Lower the helmet over your eyes. If you are not using an electronic welding helmet the first thing you will notice is that you can't see a thing. That's why it's important to line up the welding rod carefully before lowering the helmet into position. The lens in a welding helmet must be very dark to protect your eyes. Learning to strike an arc without seeing the rod tip is part of the fun of learning to arc weld.

When you begin to try to strike an arc you'll probably have the rod stick and no arc is made. When this happens, quickly wiggle the Stitch Welder to break the rod free. These thin rods should come unstuck easily.

Never be afraid to start with a fresh welding rod. Welding rods are considered expendable – a consumable. Why make things any harder by using a burned or sub standard rod? Many home restorers and pros, too, will tack weld a repair panel, let it cool while checking for fit, then use a fresh rod for the final finish weld bead.

How To Lay A Bead

To help you get the feel of the welder, practice dragging the rod tip along the sheet metal. Don't worry about trying to get an arc going just yet. Just get a feel for how the arc looks, the feel of the slight vibrations of the Stitch Welder and the change in sound in your welder. Get comfortable just dragging the tip of the rod, and making some sparks. When you are finding it easy to make sparks, try raising the rod just a little and try to get an arc going.

4. ONCE THE ARC IS MADE, THE ROD WILL CARRY THE ARC AS YOU MOVE THE ROD ALONG THE JOINT.

Let the solenoid's "stitching" action do the work. It will help take some of the guesswork out of "How long should the arc be?" Many Stitch Welder users began by simply laying the rod on the work, letting the stitching action establish the gap.

If the rod is moved too quickly, you'll get a narrow bead with little, if any, penetration. If you have trouble keeping the arc going, you may be traveling too fast, or have the rod too far from the work. Remember the motion of feeding the rod down into the work as you also move it across the joint.

This can be a little confusing at first and requires some coordination. The electrode must be lowered, or fed into the work at the same rate it is consumed by the arc, and, at the same time, it must be kept in forward motion and without changing the angle of the electrode to the work.

All of this requires practice and is much like driving a car. You need to develop a reflex action, to be able to do the job without actually having to think about it. Moving the rod too slowly is easy to spot – you'll burn through the sheet metal.

5. DON'T BE TEMPTED INTO TRYING TO GET TOO FANCY.

Many welders use a weaving or circling motion to build up the weld bead. This is fine after you get some experience. But for now, work on "drag welding" – just dragging the rod in a straight line across the sheet metal. Using a welder's soapstone to mark a line makes it easier to see and helps get those beads straight. Try to work on being smooth and steady.

How To Lay A Bead

6. WHEN WELDING, DON'T LOOK AT THE ARC ITSELF.

Try to watch the area where the rod has been – the molten puddle of metal the rod just created. With the small arc of low amperage welders, you have to get close enough for a good look.

TECH TIP: A good exercise is to draw a series of lines with your soapstone, about 1/2" or 3/4" apart on your practice piece. Work on running straight beads, following those soapstone lines. As you practice running the beads, you should be able to see progress – welds will be better, more consistent, and you should have less trouble striking the arc

Practice piece with soapstone guide lines.

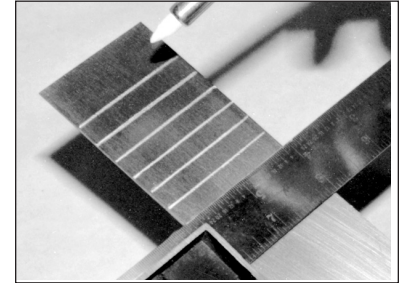

7. SOME WELDERS USE A "ONE STEP FORWARD, HALF STEP BACKWARDS" MOTION.

This means they'll try to move the tip of the welding rod "one step," say, a quarter inch forward, then move the tip a "half step" about an eighth inch backward. The goal here is to build up little layers of weld, called "shingles" much like the overlapping shingles on a house roof. The forward, then backward motion accomplishes this. It's a useful skill to develop, especially later on when you attempt vertical welding. Here, you'll be trying to build the "puddles" as they harden, one on top of another, a little like using building blocks, each weld "puddle" supported by the one below it.

8. AFTER LAYING A FEW BEADS, CAREFULLY CHIP OFF THE SLAG SO YOU CAN EXAMINE YOUR WORK.

A quick rubdown of the bead with a wire brush will also help you inspect your work and check your progress.

CAUTION: Slag can be dangerous. It gets hot, has very thin and razor sharp edges, and can pop up into your eye when chipping. **BE CAREFUL. WE RECOMMEND WEARING SAFETY GOGGLES (#43090) WHEN CHIPPING SLAG.**

Troubleshooting

In the event you experience difficulty getting welds from your Stitch Welder, there are a number of things to check. Consult the chart below to identify the problem, find the cause and then take the suggested corrective action.

Problem	Possible Cause: Corrective Action
<p><i>Welder will not work;</i> <i>No sound from welder;</i> <i>No spark from welding rod tip</i></p>	<p>No power to welder:</p> <ul style="list-style-type: none"> • Make sure welder is plugged in and switched on. • Check your welder's manufacturer's instructions. • Welder overload protection may have temporarily shut welder down. • Make sure house fuse or circuit breaker is ON. • Make sure ground connection is hooked up to bare steel.
<p><i>Welder hums but no spark from welding rod tip</i></p>	<p>Welding circuit is not complete:</p> <ul style="list-style-type: none"> • Make sure ground connection is hooked up to bare steel. • Make sure Stitch Welder pin connector is clamped firmly in welder's electrode holder. • Wrong electrode: Change electrode. Use Eastwood Stitch Welder Rods (#19001). • Paint, rust, etc. on work: Clean weld area to expose bare metal.
<p><i>Difficult to strike arc</i></p>	<ul style="list-style-type: none"> • Work area not clean: Clean weld area to expose bare metal. • Arc current too low: Turn diode control screw in to bypass diode, giving 100% output of main welder's setting. • Wrong electrode: Change electrode. Use Eastwood Stitch Welder Rods (#19001). Tap electrode on hard insulated surface to remove slag from end of rod.
<p><i>Arc burns through sheet metal</i></p>	<ul style="list-style-type: none"> • Amperage set too high: Adjust amperage on your welder lower or turn diode control screw out putting diode in circuit, cutting output to 50% of main welder's setting. • Moving rod too slowly: Move rod along joint at a slightly faster rate. • Gaps between the pieces of sheet metal: Clamp tightly together. Upper layer of sheet metal will tend to curl with application of welding heat. Clamp tightly together. Use tack welds.
<p><i>Insufficient weld penetration</i></p>	<ul style="list-style-type: none"> • Arc current set too low: Adjust amperage on your welder higher or turn diode control screw in to bypass diode, giving 100% output of main welder's setting. • Wrong size rod: Use Eastwood's Stitch Welder Rod (#19001). • Moving rod too quickly: Slow down rod tip movement.
<p><i>Distortion/warping</i></p>	<ul style="list-style-type: none"> • Welds spaced too closely: If a number of welds are to be made in a small area, allow enough cooling time between welds. • Welds made in too long a continuous pass: Weld in a "skip" pattern. • Too few "tack" welds: Use enough tack welds or clamps to keep work from "crawling". • Use Eastwood's Anti-Heat Compound (#31042) to confine heat and minimize warpage.

Testing Your Welds

The key to good weld penetration is the proper balance of heat, speed, and your skills as a welder. On flat welds, look for penetration on the underside of the workpiece. The underside will show penetration by how much metal "drops through". If there is little sign of any metal dropping through under the weld bead, there isn't any penetration and the result will be a very weak weld bead. If you see you aren't getting good weld bead penetration, try slowing down just a little.

To test some practice weld beads, solidly clamp the piece to be tested in a vise on to a steel table just below or beside the weld bead. Bend the piece over at the welded joint with a hammer. If the weld penetration is good, the weld won't break. The metal should bend completely over or break next to the weld, but not through the weld.

To test small pieces, grip one end in a vise and twist the other end, lengthwise.

If your weld beads pass the bending test, hacksaw some welds apart crosswise. This allows you a good look at the penetration of the bead and will help you spot problems such as undercutting.

There are more complicated tests used in the welding industry, but these are reliable, easy to do in the home shop and demonstrate the weld's quality.

Work so your practice welds can stand up to this kind of test over and over again, before getting on to a real welding project.

Proper Weld Penetration

Think in terms of an actual size or length, think of the arc as having a “range” that you can vary to have some control over the heat. The longer the arc, the higher the temperature. If the arc gets too long, the color changes, and the sound can change from a smooth hiss to a harsh crackle along with lots of excess splatter.

If the arc is allowed to get too long, it will go out. Too short and the rod will stick, short circuiting the machine’s output and overheating the rod.

The drawing illustrates a “cross section” of weld beads on a single piece of stock (a practice piece).

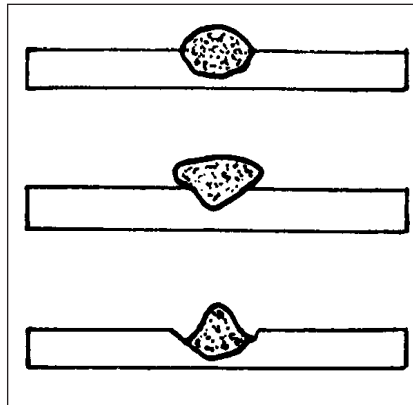

The top bead shows proper penetration and weld build up.

The middle bead “hangs over” or overlaps. This is called overlay and isn’t considered an acceptable weld bead.

The lower drawing shows a bead with grooves on either side. This is called “undercutting” and again, isn’t considered acceptable.

One key to welding autobody sheet metal is that you must always make sure that the two pieces of sheet metal being welded are clamped tightly together. There must be no space between the two pieces of sheet metal being lap welded. The welding heat quickly spreads on thin sheet metal and the metal will “crawl” apart. So take care to clamp the metal tightly, use tack welds and above all, work to make a tight fit without voids.

Welding Techniques

Butt Joints

A Butt Joint is simply two pieces of metal joined edge-to-edge by a weld bead. It requires careful use of the electrode, more so than just making practice beads on a single piece of sheet metal. What complicates things is penetration. The exposed edges of the sheet metal absorb heat faster than a solid surface, increasing the tendency to burn holes.

A good butt weld should have penetration the full depth of the joint, so a small bead is formed on the lower surface and a much larger bead is formed on the upper surface. The set of four Intergrrips (#19016), shown here with the MIG Welder, also works well with the Stitch Welder.

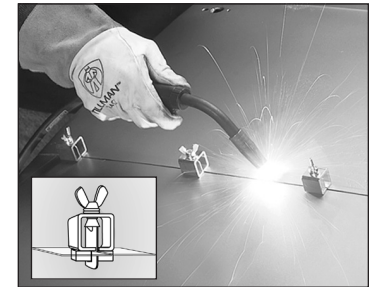

Butt welds on anything thinner than 1/8" can be very difficult and aren’t often used on autobody work. Since the sheet metal will tend to “crawl” apart from the welding heat, you must always tack weld the butt joint along its entire length. Make additional tack welds between the first group until the tack welds are about an inch or so apart. Then begin to run the final weld bead. Expect some distortion from the heat, which can usually be corrected by some hammer and dolly work.

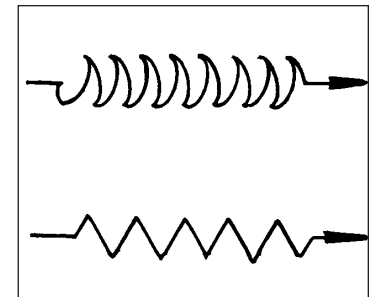

Some people find it easier to use a weaving motion or circular pattern with the electrode making a somewhat wider bead than necessary. This spreads the heat and helps prevent burn through. Feel free to practice changes in electrode angle, arc length, and rate of travel to find a combination that works well to suit the thickness of the sheet metal you are using and your welding technique.

The illustration on the following page shows four cross sections of common results of butt welding. A beginner’s attempt to avoid burning holes usually leads to piling up too much on the upper surface and not enough penetration, as shown in weld **A** (shown on page 14). A weld is not considered acceptable if it shows traces of the original edge.

Welding Techniques

Weld **B** is a good weld with full penetration. There's a slight bead on the lower surface and a full bead blended into the upper surface. Weld **C** shows the beginning of undercutting due to too much penetration. The puddle isn't filling either. The weld will be weak because of the undercutting. Weld **D** shows even greater undercutting – another unacceptable weld.

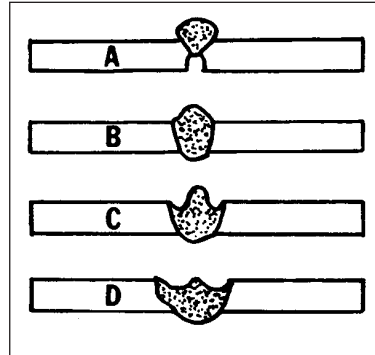

While it's true that welds on autobody panels aren't as critical as frame or suspension component welds, you should still work and practice toward making good welds.

Lap Joints

Lap joints are where two pieces of sheet metal overlap each other. This is a type of joint often used in auto repair work.

A good lap weld should have the proper amount of weld bead penetration, but without meltback of the upper edge or overlay. The reason for this is that if the upper layer melts too much, the joint will be thin and weak. There is also the possibility the inner edge will not fuse properly, resulting in a weak weld. The weld will break easily when tested.

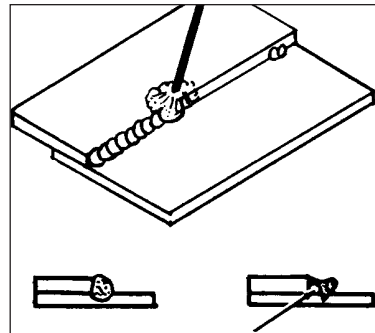

Lap joint is used where panels overlap. Note tack weld at opposite end from where welding bead begins. This helps keep the panels from moving apart due to heat expansion. Lower left shows an acceptable lap weld bead. Lower right shows unacceptable weld with poor penetration with the result, a gap where no weld reached the necessary are (shown by arrow). Also "undercutting" is present at front of bead.

Many welders, especially beginners will find it easier to use a weaving pattern with the electrode, zigzagging back and forth across the lap joint. This helps avoid melting too much of the exposed upper edge. The idea is to allow the melted metal at one end of the weave to partly solidify before adding more, but being careful not to allow the bead to cool too much. It takes practice but is a useful skill for body repair.

Welding Techniques

Flange Joints

Flange joints are the most useful type of joint for autobody patch panel installation. Eastwood's flanging pliers (#31092) or the combination Holepunch/Flanger (Hand #31018 / Pneumatic #31015) can be used to put an offset into one side of the panel being welded. The flange can be put on either the auto's sheet metal or on the patch panel.

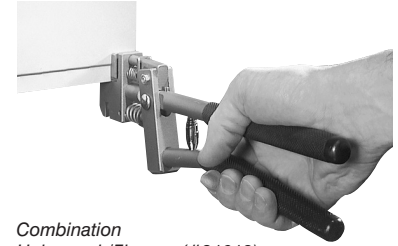

Combination Holepunch/Flanger (#31018)

Flange joints are welded much like lap joints. The real advantage is that after the weld bead is ground smooth, very little filler is required for a smooth joint.

Sometimes when welding a flanged joint or a lap joint, it seems as if the weld doesn't want to go where you want it to go. This also happens when welding in a corner and is caused by the magnetic field that has formed around the tip of the electrode. To overcome this, try changing the angle of the electrode to the work. Imagine the welding rod tip is a tiny spray at a different angle, you'll be able to get the weld bead where it's needed.

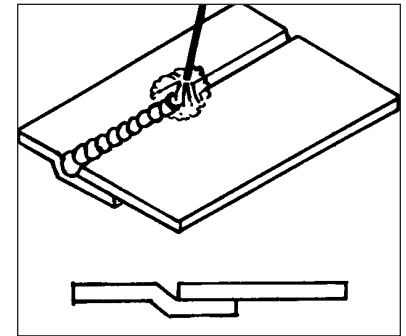

Flange joints are the most used joints in welding body panels in repair and restoration. Note the position of the panels. Special tools, both hand and air powered are available to make this special offset flange.

A good way to check your progress on lap joints and flange joints is to hacksaw the practice piece crossways to check for penetration and undercutting.

Button Welds/Spot Welds

Button welds, sometimes called rivet welds can be made by starting the arc and keeping the rod in one place. This will, of course, burn through the metal, especially if the electrode is pushed through the softened steel. The rod is then withdrawn, the object being to fill the hole with the rod as filler, producing what's called a button weld. These often look like slightly oversized spotwelds.

■ Welding Techniques

A technique that really works well with the Stitch Welder is to drill or punch a series of one-eighth to one-quarter inch holes in the patch panel. Make the holes about one-half inch back from the edge of the panel and about two inches apart. One of our combination hole punch/flanger (Hand #31018 or Pneumatic #31015) is excellent for punching holes. You can make the holes through the patch panel, not the fender (we'll call it the "base metal"). Your patch panel will look almost as if you were going to bolt it on because of the holes you've drilled. Put the patch panel in place and clamp it tightly, overlapping the base metal. You should be able to see the base metal through the holes you made in the panel.

Now simply put the electrode through the holes, starting the arc metal on the base metal. Fill the holes with weld, making neat little "spotwelds". You are assured of penetration since the rod is arcing on the inner panel. All you have to do is fill the panel's holes with weld.

If you've drilled out spotwelds on a body panel and are reusing that panel again, simply weld through the holes, filling them up for a neat job.

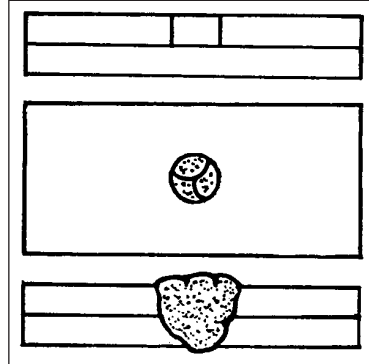

As always, one of the keys to preventing burn through is a good, close fit between the panels. Eastwood's Panel Holding System (#19074) works well for this and the small holes used by the fasteners are quickly and easily filled with weld.

Practice, Practice, Practice!

We suggest you practice as much as possible before trying your hand at autobody replacement. There are also plenty of good books available to help you learn to weld. One particularly good publication is **Welder's Handbook** by Richard Finch and Tom Monroe (available from Eastwood, #19034).

TECH TIP: *Whenever you weld, good heat control is key to good penetration and minimizing warpage. The re-usable Anti Heat Compound (#31042) placed near the weld site absorbs heat for minimal distortion.*



www.eastwood.com

If you have any questions about the use of this product,
please contact The Eastwood Technical Service Department

1-800-CAR-TEC1 (1-800-227-8321)