

Eastwood

DO THE JOB RIGHT.

Part #19871

STEP MASKING MACHINE

INSTRUCTIONS



The **EASTWOOD STEP MASKING MACHINE** is designed to provide years of rugged and reliable service. It features up to 18" wide masking paper roll capacity with cutter, 2 variable-sized masking tape dispensing locations and a stable 12"-high, non-slip rubber covered stepping surface.

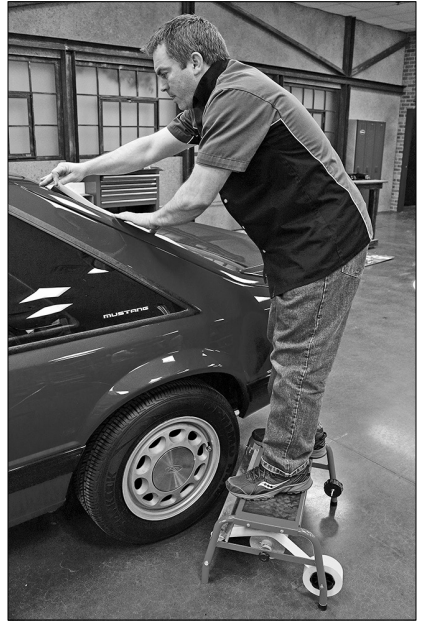

SAFETY INFORMATION

⚠ WARNING

WARNING indicates a hazardous situation which, if not avoided, will result in death or serious injury.

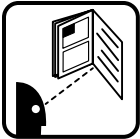

⚠ READ INSTRUCTIONS

Thoroughly read and understand this manual before using this Step Masking Machine. Save for future reference.



⚠ WARNING FALL HAZARD

- Use only on level, paved surface.
- Do not exceed 250 lbs.



⚠ WARNING CUT HAZARD

Serrated paper cutting blade is sharp and can cut skin. Use caution.

ASSEMBLY

1. Place the Step (with rubber step-surface upward) over the 2 Side “A-Frame” assemblies using supplied hardware (4, 6mm bolts, 4 nuts & 8 washers) and tighten with a 10mm wrench.

NOTE: The front side only of the A-Frames have two additional holes for blade mounting. Be sure that these are both **facing forward**.

2. Place the Support Bar at the through holes in both of the lower **front** legs of the “A-Frame” assemblies then fasten in place by threading 6mm bolts (2 pieces) with washers (2 pieces) into the threaded inserts at the ends of the Support Bar and tighten with a 10mm wrench.

3. Place the Cutting Bar with blade teeth facing **outward** and downward at the forward facing through holes in both of the upper **front** legs of the “A-Frame” assemblies then fasten in place with 4, 6mm bolts, 4 nuts & 8 washers (**FIG. 1**). Tighten with a 10mm wrench.

4. Attach the Guide Spring to the **underside** of the Cutting Bar by stretching and hooking the ends into notches on the ends of the Cutting Bar (**FIG. 1**).

5. Place 2 black plastic Tape Roll Spools (flange in) at the through holes of the lower **rear** legs and fasten in place with 6mm bolts (2 pieces), lock nuts, (2 pieces) wing nuts (2 pieces) and 4 washers. Finger tighten Wing Nuts only (**FIG. 2**).

6. Place the Paper Roll Bar at the 2 center through holes at the flat cross-bars of the “A-Frame” side assemblies and attach by threading two 10mm bolts with hand knobs into the threaded inserts of the Paper Roll Bar (**FIG. 3**). Hand snug only.

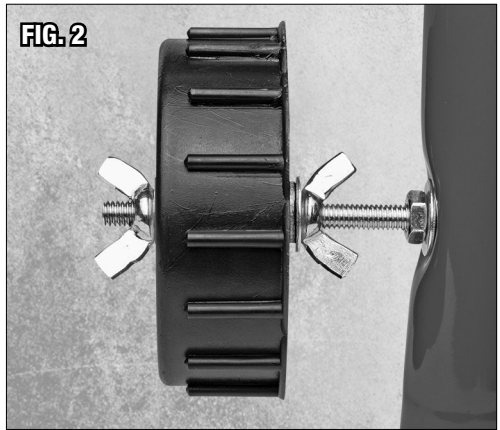
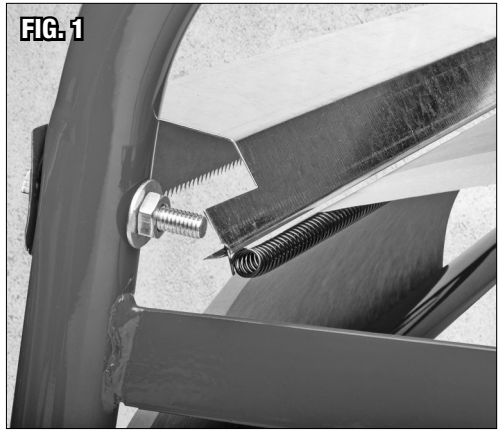

USE

1. Place the masking paper roll on the Paper Roll Bar with the paper feed edge leading **overhead and forward**. **NOTE:** It is important to use the 2 Tensioning Collar/Coil Spring sets to apply a **slight** amount of tension on the paper with the Tensioning Collars and tighten the set-screws with a Phillips screw driver (**FIG. 2**).

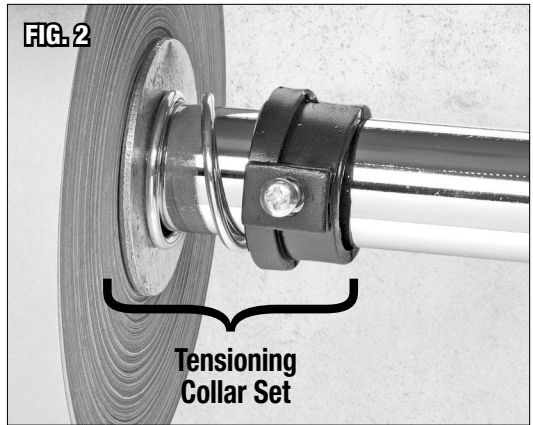

2. Feed the paper edge **under** the Cutting Bar and over the Guide Spring and pull paper between both and toward the front.
3. Place masking tape rolls on the Tape Roll Spools with the feed edge leading **overhead and forward**. **NOTE:** Use with 1-1/2" minimum width masking tape for best results.
4. Pull tape forward to contact the top and edge of the masking paper roll allowing it to adhere to and join with the paper edge.

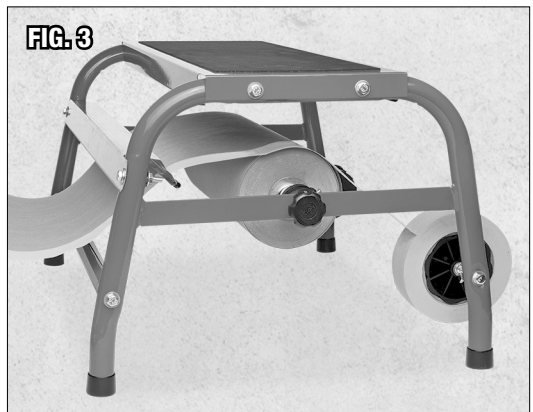

5. Pull the paper with tape attached at side (or sides) through the Cutting Bar and Guide Spring. **NOTE:** Some adjustments to the tape and paper spools will be required to properly align the tape and paper edges for proper masking (**FIG. 3**).
6. To cut, grasp paper by the edge and sharply pull upward and across teeth to cut.

If you have any questions about the use of this product, please contact

The Eastwood Technical Assistance Service Department: 800.544.5118 >> email: techhelp@eastwood.com

PDF version of this manual is available online >> eastwood.com/19871manual

The Eastwood Company 263 Shoemaker Road, Pottstown, PA 19464, USA

US and Canada: 800.345.1178 Outside US: 610.718.8335

Fax: 610.323.6268 eastwood.com