

Eastwood

DO THE JOB RIGHT.

Item #20027

BLAST CABINET

INSTRUCTIONS

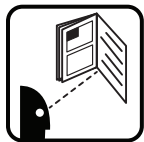


The **EASTWOOD BLAST CABINET** is specifically designed with heavy-duty components and a quality powder coated finish to provide years of trouble-free service. It features a fluorescent work lamp for increased visibility and a baffled, flow-through ventilation design with an external vacuum connection for portable or bolt-on vacuums.

SAFETY INFORMATION

⚠️ WARNING

WARNING indicates a hazardous situation which, if not avoided, will result in death or serious injury.



⚠️ READ INSTRUCTIONS

Thoroughly read and understand this manual before using the Eastwood Blast Cabinet. Save for future reference.



⚠️ WARNING ELECTRIC SHOCK HAZARD!

- **Always** plug into a properly grounded outlet.
- Under certain conditions (e.g. atmospheric humidity levels, type of media being used and/or type of media being blasted), the friction of abrasive blasting may generate static electricity and result in shocking. We recommend grounding the blast cabinet in accordance with local electrical codes.
- For indoor use only.



⚠️ WARNING HEALTH HAZARD!

- Do not use with sand containing crystalline silica. Exposure to crystalline silica may cause silicosis, a serious lung disease, cancer, and death.
- Dust generated by the blasting process can contain hazardous materials such as lead, zinc chromate, cadmium, and other toxic compounds. Always wear a NIOSH-approved breathing apparatus when abrasive blasting.
- **Never** operate the blast cabinet with the door open. Always make sure the door is securely latched and sealed before operating.
- **Never** operate the blast cabinet without a properly filtered shop-type, dust collecting vacuum. If dust is seeping out of your vacuum filter, stop immediately and replace filter!

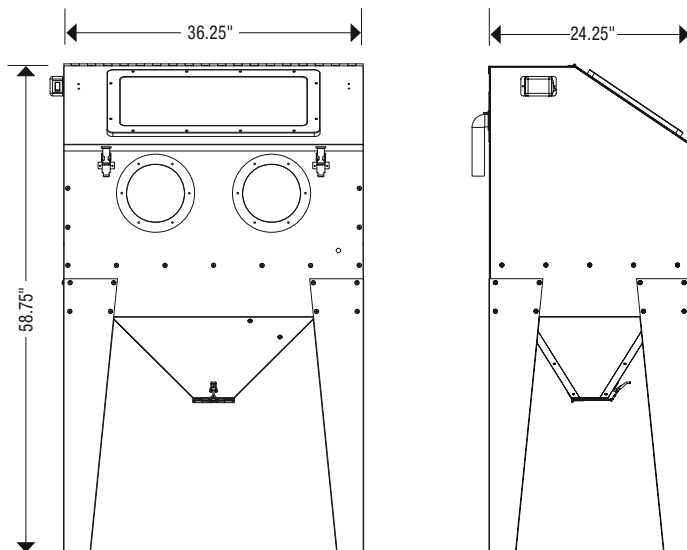


⚠️ WARNING OPERATION WARNINGS!

- **Never overload the blast cabinet.** Maximum weight capacity of object to be blasted is 100 lbs. Maximum weight capacity of blast media is **50 lbs.**
- **Always** use a clean, dry, regulated air supply. Moisture and or oil in air supply will cause clogging of blast media. Inlet air pressure must not exceed 120 PSI. **Excessive air pressure can cause permanent damage to the unit and personal injury.**
- Disconnect air supply before making adjustments, changing accessories, or storing the cabinet.
- Never use and bottled gas as an air source for this cabinet,

SPECIFICATIONS
















- Electrical current requirement (lamp): 120 Volt AC, 60hz; 3 amp
- Air supply requirements: 7 CFM @ 90 PSI.
- Internal Dimensions: 36" wide x 24" deep x 23" high.

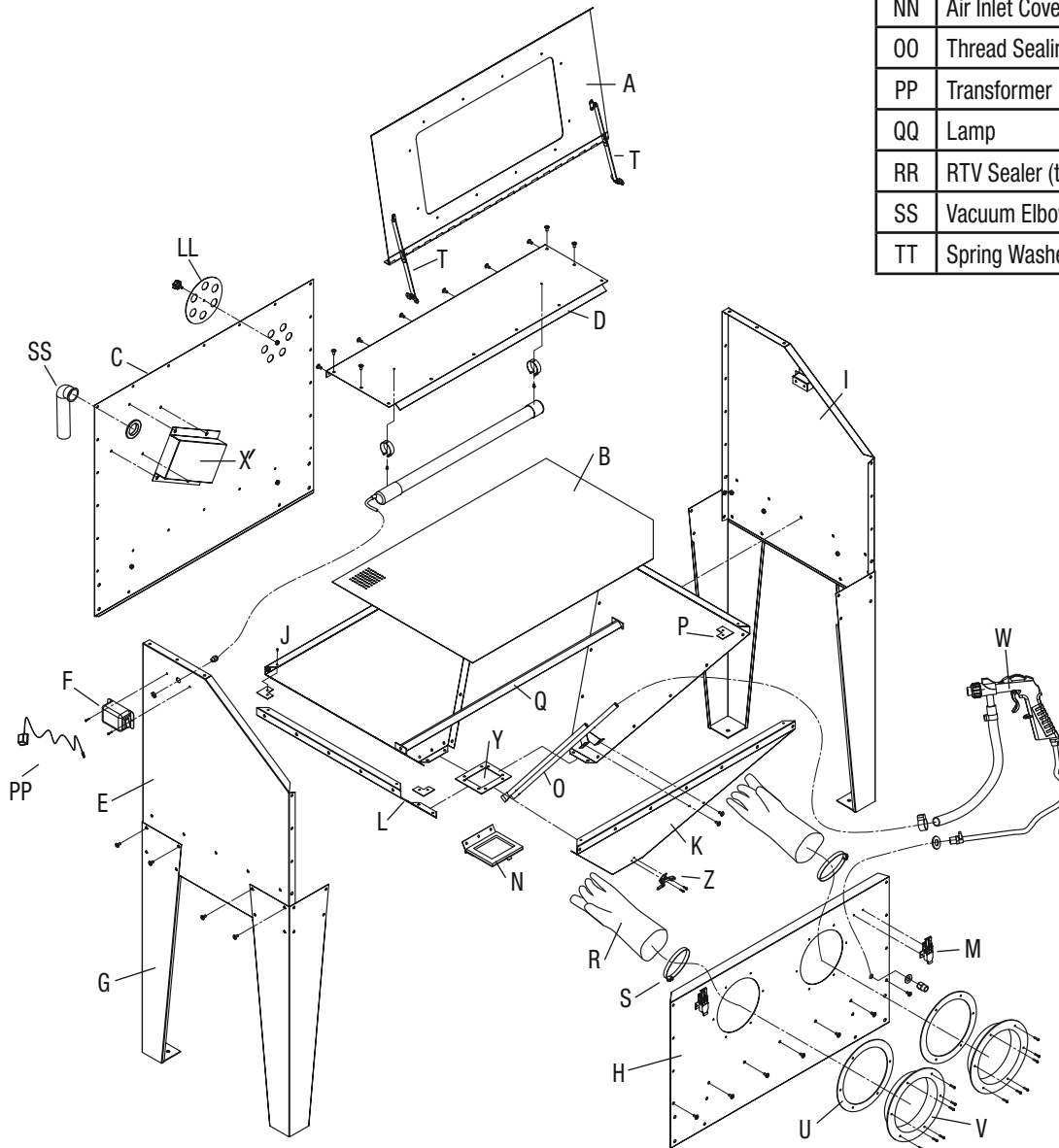


INCLUDES

Part	Description	Qty.
A	Door	1
B	Shelf	1
C	Cabinet Back Panel	1
D	Cabinet Top Panel	1
E	Cabinet Left Side Panel	1
F	Switch Box	1
G	Leg	4
H	Cabinet Front Panel	1
I	Cabinet Right Side Panel	1
J	Hopper Back Panel	1
K	Hopper Front Panel	1
L	Hopper Side Panel	2
M	Latch	2

Part	Description	Qty.
N	Hopper Drain Door	1
O	Media Suction Tube	1
P	Hopper Corner Reinforcements	4
Q	Shelf Floor Supports	1
R	Gloves	1
S	Hose Clamp	2
T	Door Supports	2
U	Seal Ring	2
V	Glove Seat	2
W	Media Blasting Gun	1
X	Vacuum Baffle	1
Y	Hopper Bottom Frame	1
Z	Lock	1

Part	Description	Qty.	
AA	M6 x 12mm Screw	118	
BB	M4 x 16mm Screw	15	
CC	M4 x 10mm Screw	30	
DD	M4 x 6mm Screw	2	
EE	M6 Nut	75	
FF	M4 Nut	20	
GG	M4 Flat Washer	35	
HH	Lamp Clip	2	
II	Nylon Cable Tie	2	
KK	Sealing Foam Thin Foam for use between panels, Thick Foam for use on Door	2	
LL	Air Input Regulating Plate	1	
MM	Knob Screw	1	
NN	Air Inlet Cover	1	
OO	Thread Sealing Tape	1	
PP	Transformer	1	
QQ	Lamp	1	
RR	RTV Sealer (tube)	1	
SS	Vacuum Elbow	1	
TT	Spring Washer	4	



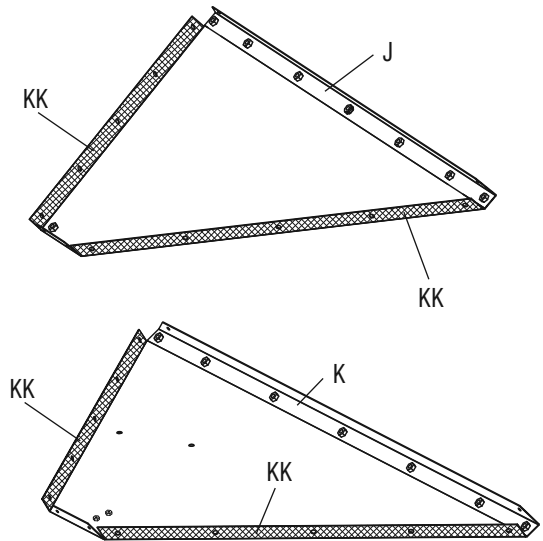
HOPPER ASSEMBLY

⚠ WARNING ASSEMBLY HAZARD!

- Install a shutoff valve on the air supply line for emergency shutoff.
- Wear safety goggles and work gloves during assembly.

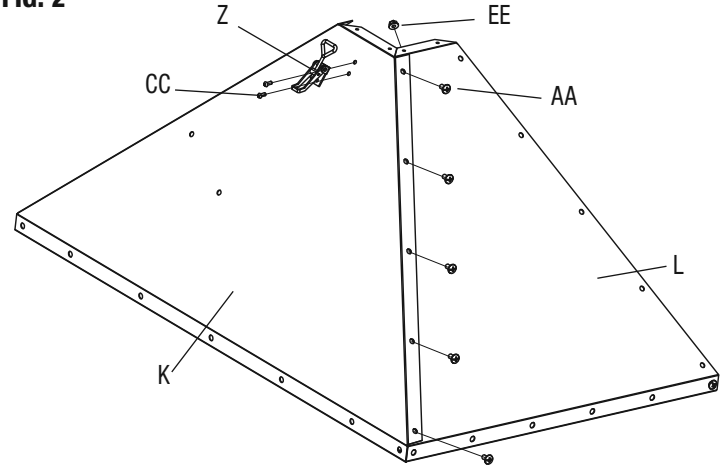
1. Peel away protective paper and apply Thin Sealing Foam (KK) on the inner face, along the bottom of the flanges of Hopper Back Panel (J) and Hopper Front Panel (K) (FIG. 1).

FIG. 1



2. Install Hooper Drain Latch (Z) onto Hopper Front Panel (K) with loop facing small end and attach with 2 M4 x 10 screws (CC) then tighten (FIG. 2).
3. Attach 1st Hopper Side Panel (L) to Hopper Front Panel (K) with 5 M6 x 12mm screws (AA) and nuts (EE) trapping the Sealing Foam between panels. (Do not fully tighten screws at this time) (FIG. 2).

FIG. 2



2 Pcs. CC M4 x 10mm Screw



5 Pcs. AA M6 x 12mm Screw

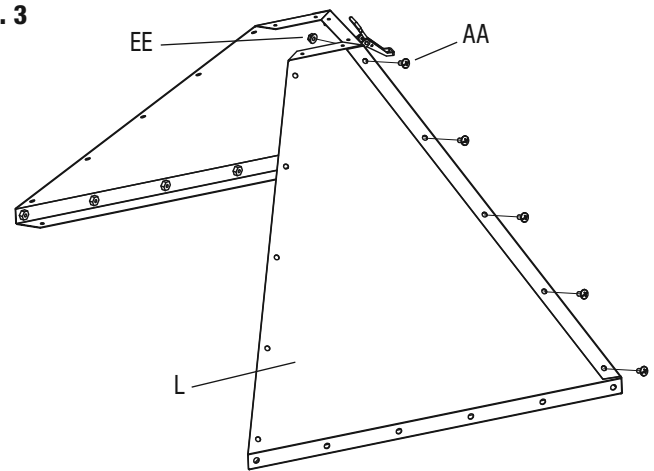


5 Pcs. EE M6 Nut



4. Attach 2nd Hopper Side Panel (L) to opposite side of Hopper Front Panel (K) with 5 M6 x 12mm screws (AA) and nuts (EE) trapping the Sealing Foam between panels. (Do not fully tighten screws at this time) (FIG. 3).

FIG. 3



5 Pcs. AA M6 x 12mm Screw

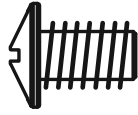


5 Pcs. EE M6 Nut

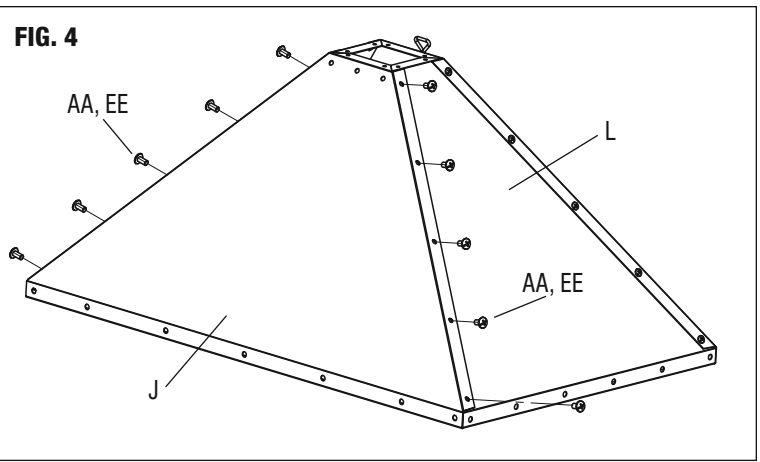


1. Attach Hopper Back Panel (J) to Hopper Side Panels (L) with 5 M6 x 12mm screws (AA) and nuts (EE) trapping the Sealing Foam between panels (**FIG. 4**).
2. Make sure all four panel edges at top and bottom of Hopper Assembly are flush and then evenly tighten the M6 x 12mm screws (**FIG. 4**).

5 Pcs. AA M6 x 12mm Screw



5 Pcs. EE M6 Nut



3. Peel away protective paper and apply Thin Sealing Foam (KK) on the bottom of the flange of Hopper Assembly (**FIG. 5**).
4. Attach Hopper Bottom Frame (Y) to Hopper Assembly with 8 M4 x 10mm screws (CC) and 4mm Flat Washers (GG). Tighten screws (**FIG. 5**).
5. Install the Hopper Drain Door (N) to Hopper Back Panel (J) with 3 M6 x 12 mm screws and tighten (**FIG. 5**).

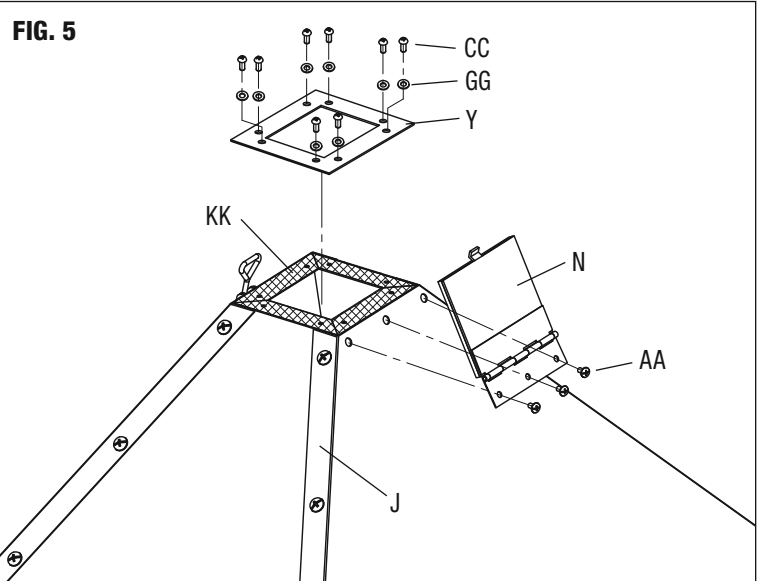
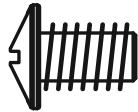
8 Pcs. CC M4 x 10mm Screw



8 Pcs. GG M4 Washers



3 Pcs. AA M6 x 12mm Screw

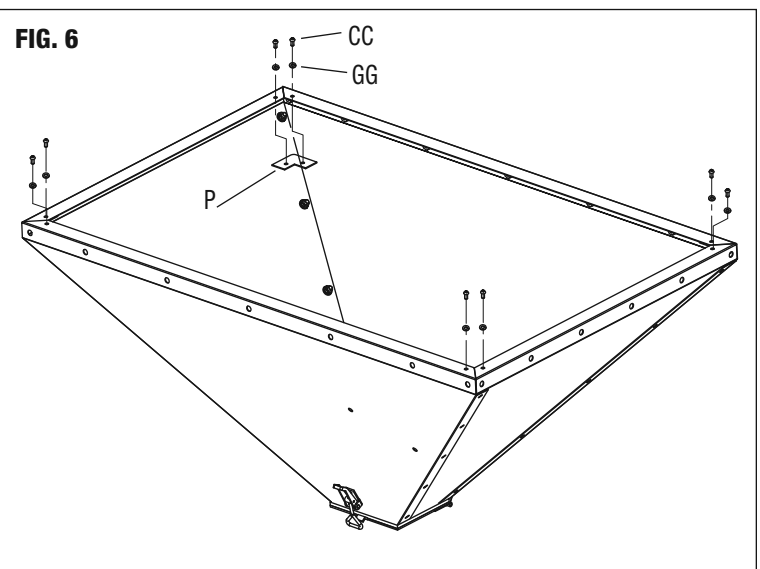


6. Attach 4 Hopper Corner Reinforcements (P) to the INSIDE of Upper Hopper Flange with 4 M4 x 10mm screws (CC) and 4mm Flat Washers (GG). Tighten screws (**FIG. 6**).

8 Pcs. CC M4 x 10mm Screw



8 Pcs. GG M4 Washers



1. Install Media Suction Tube (O) to Hopper Front Panel (K) with 2 M6 x 12mm screws (AA) and nuts (EE) (FIG. 7).

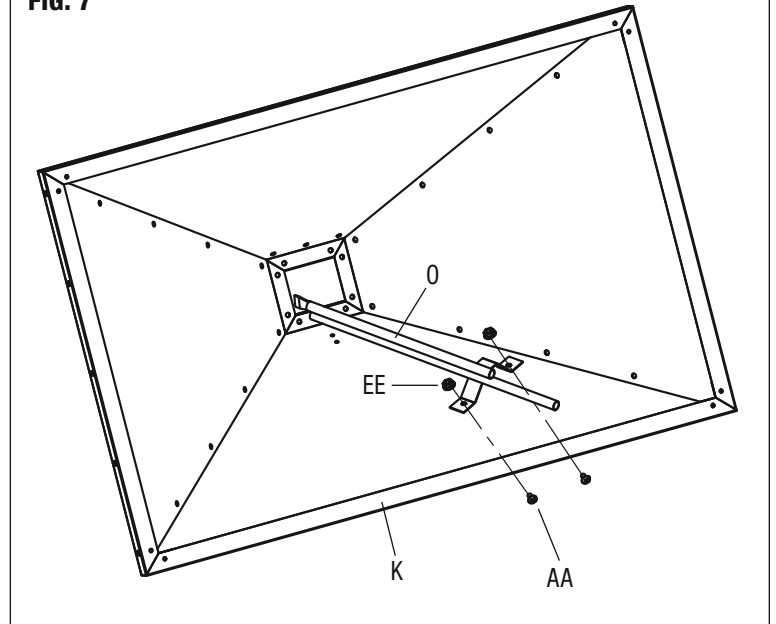
2 Pcs. AA M6 x 12mm Screw



2 Pcs. EE M6 Nut

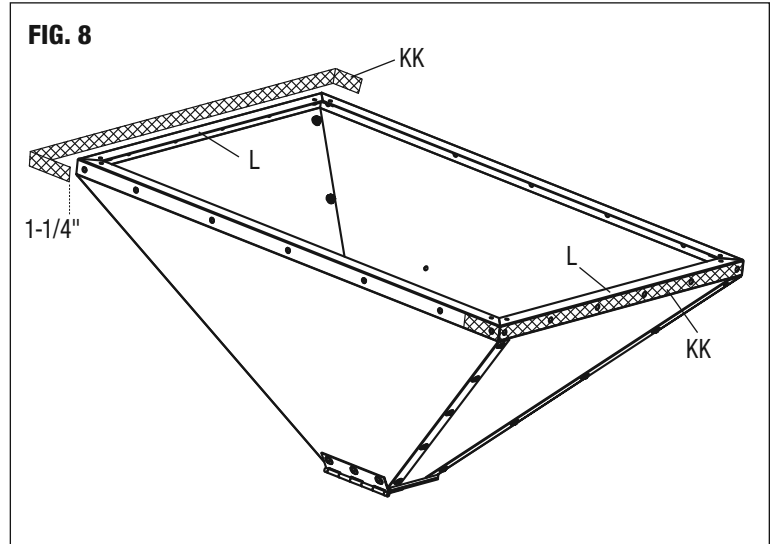


FIG. 7



2. Peel away protective paper and apply Thin Sealing Foam (KK) on the upper OUTER surface of the Hopper Side Panels (L). Wrap the Sealing Foam around the front and back of the Hopper Assembly about 1-1/4" (FIG. 8).

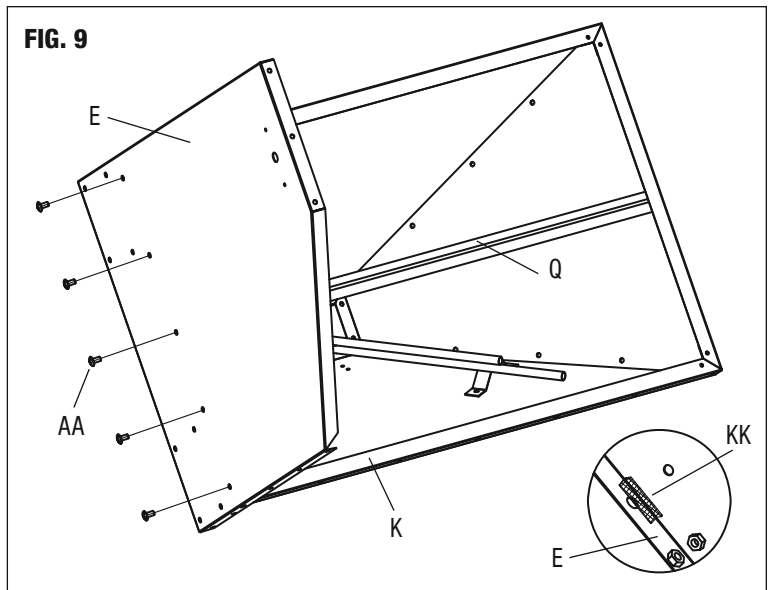
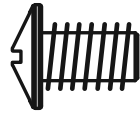
FIG. 8



CABINET ASSEMBLY

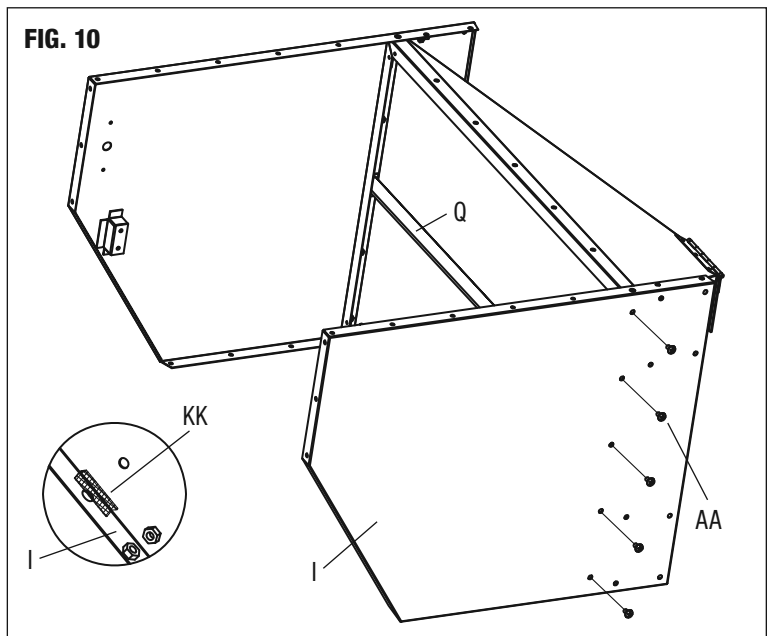
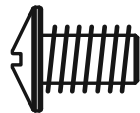
1. Attach Cabinet Left Side Panel (E) with 4 M6 x 12mm Screws (AA) in outer 4 holes only, (no screws in center holes at this time). **NOTE:** Be sure that Left Side Panel (E) is installed with the angled corner facing upward and forward (**FIG. 9**).
2. Install Shelf Floor Support (Q) (**NOTE:** open side downward) to Cabinet Left Side Panel (E) with 2 M6 x 12mm Screws (AA) (**FIG. 9**).

5 Pcs. AA M6 x 12mm Screw

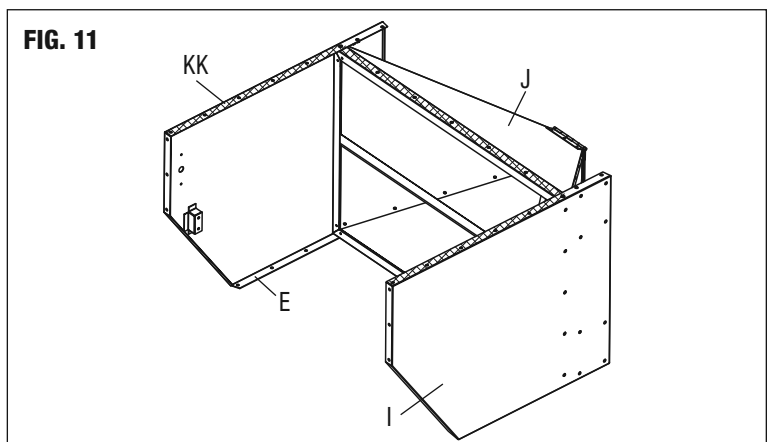


3. Attach Cabinet Right Side Panel (I) & Shelf Floor Support (Q) with 6 M6 x 12mm Screws (AA) (**FIG. 10**).
4. Tighten all screws (**FIG. 10**).

5 Pcs. AA M6 x 12mm Screw



5. Peel away protective paper and apply Thin Sealing Foam (KK) along the rear flanges of Cabinet Side Panels (E) and (I) and Hopper Back Panel (J) (**FIG. 11**).



1. Attach Cabinet Back Panel (C) to the rear flanges of Cabinet Side Panels (E) and (I) and Hopper Back Panel (J) with 15 M6 x 12mm screws (AA). **NOTE:** not all holes receive screws at this time, refer to figure 12 for locations and be sure that larger punched holes are in proper orientation. (Do not fully tighten screws at this time to allow for alignment of remaining leg holes.) (FIG. 12).
2. Install 2 Legs (G) to the rear flanges of Cabinet Side Panels (E) & (I), Cabinet Back Panel (C) and Hopper Back Panel (J) with 16 M6 x 12mm screws (AA) and nuts (EE). Tighten all screws (FIG. 12).

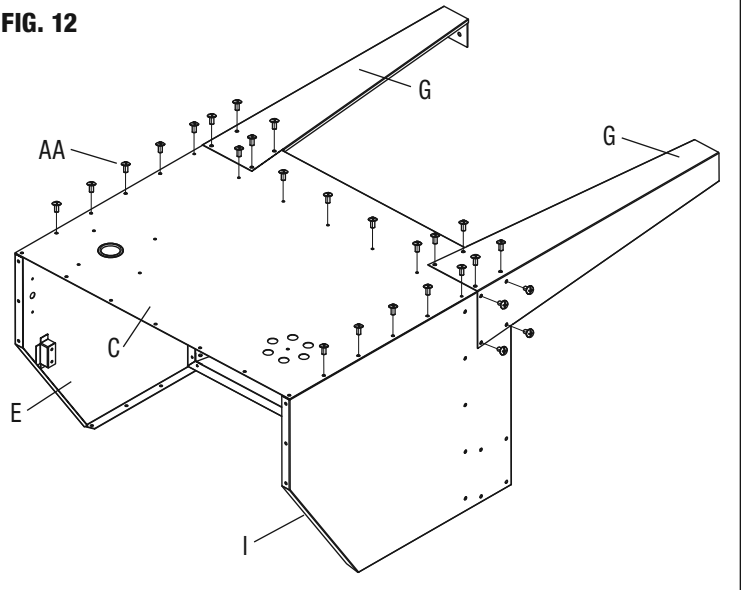
31 Pcs. AA M6 x 12mm Screw



24 Pcs. EE M6 Nut

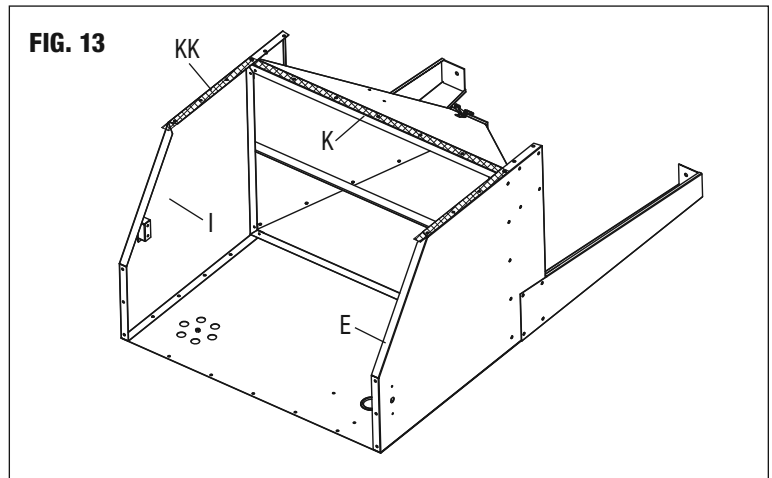


FIG. 12



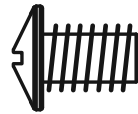
3. Peel away protective paper and apply Thin Sealing Foam (KK) along the front-facing flanges of Cabinet Side Panels (E) and (I) and Hopper Front Panel (K) (FIG. 13).

FIG. 13



4. Attach Cabinet Front Panel (H) to the front flanges of Cabinet Side Panels (E) & (I) and Hopper Front Panel (K) with 13 M6 x 12mm screws (AA). **NOTE:** not all holes receive screws at this time, refer to figure 12 for locations. (Do not fully tighten screws at this time to allow for alignment of remaining leg holes) (FIG. 14).
5. Install 2 Legs (G) to the rear flanges of Cabinet Side Panels (E) and (I), Cabinet Front Panel (H) and Hopper Front Panel (K) with 16 M6 x 12mm screws (AA) and nuts (EE). Tighten all screws (FIG. 14).

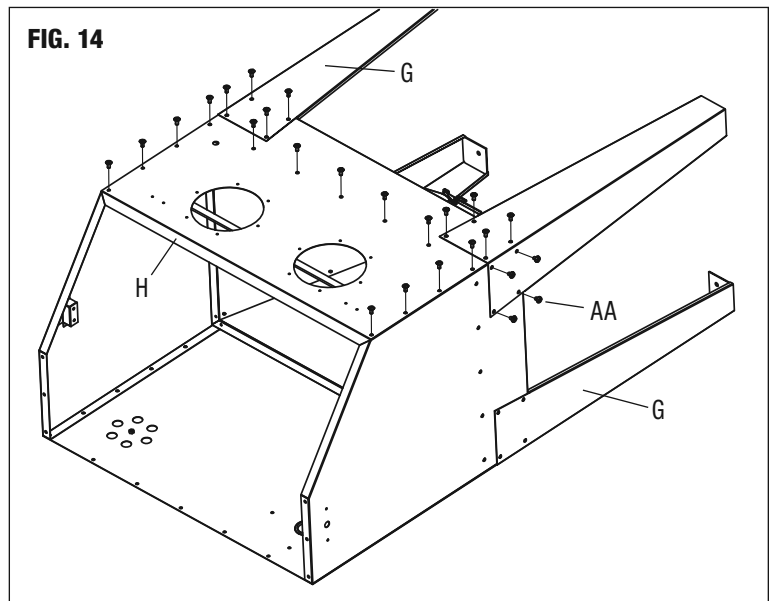
29 Pcs. AA M6 x 12mm Screw



16 Pcs. EE M6 Nut

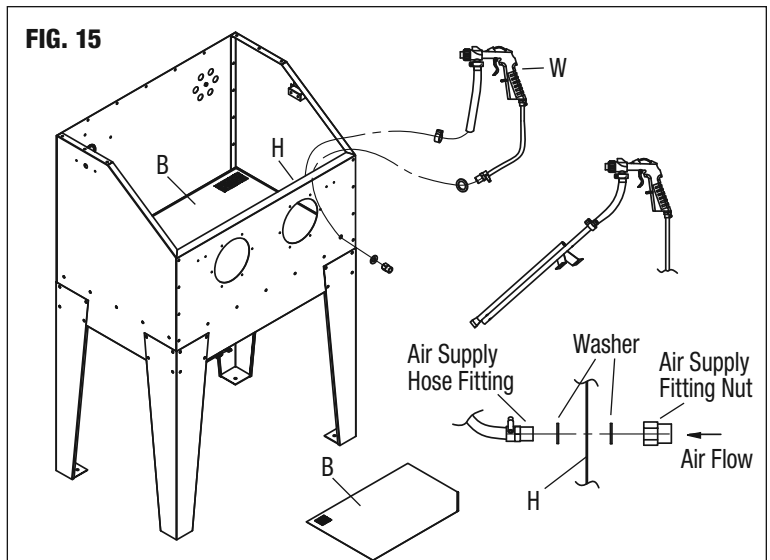


FIG. 14




INSTALLING REMAINING COMPONENTS

1. Stand assembled unit up on it's legs (**FIG. 15**).
2. Install the Media Blasting Gun (W) Suction Hose to the Media Suction Tube (O), secure with a Hose Clamp and tighten (**FIG. 15**).
3. Place the Media Blasting Gun (W) Air Supply Hose Fitting through the through hole in the lower right corner of the Cabinet Front Panel (H) using a large flat washer on either side. Wrap thread sealing tape around fitting threads and secure with the Air Supply Fitting Nut (**FIG. 15**).
4. Let the Media Blasting Gun (W) hang out of the right front corner of the Cabinet (**FIG. 15**).
5. Set the Shelf (B) (with angled cut off corner toward right front of cabinet) and allow it to rest on the hopper flanges and Shelf Floor Support (Q) (**FIG. 15**).



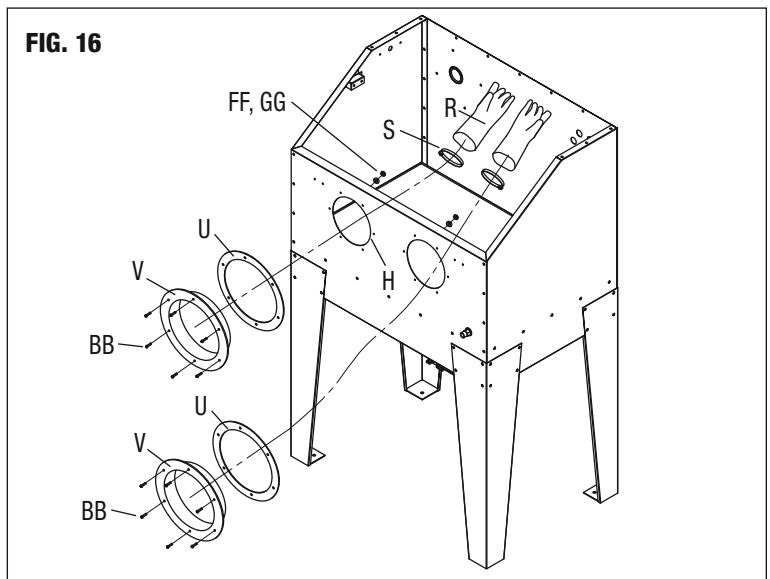
6. From the outside, install 2 sets of Seal Rings (U) and Glove Seats (V) into the large holes in the Cabinet Front Panel (H) and secure with 12 M4 x 16mm screws (BB), flat washers, (GG) and nuts (FF) (**FIG. 16**).

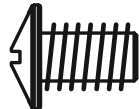
12 Pcs. BB M4 x 16mm Screw 

12 Pcs. GG M4 Washers 

12 Pcs. FF M4 x 12mm Screw 

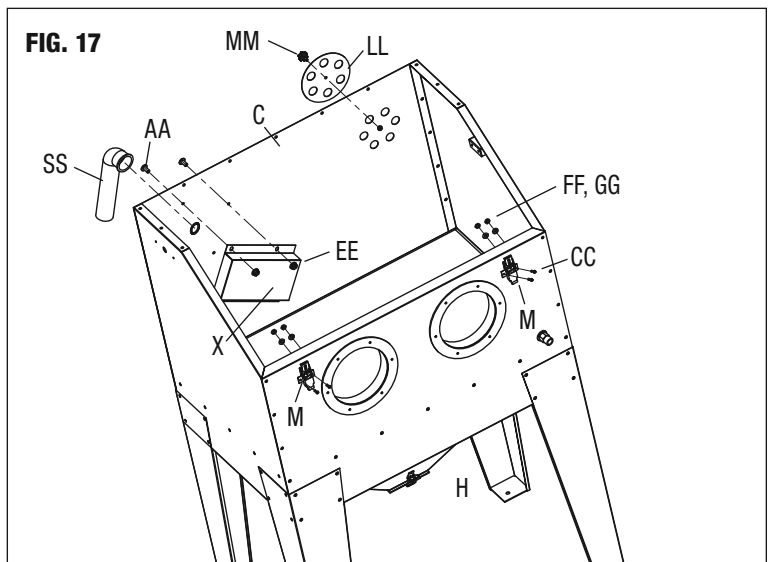
7. Fit 2 Hose Clamps (S) over the Glove Sleeves then slide the Gloves (R) fully over the Glove Seats (V) then tighten Hose Clamps (S) securely (**FIG. 16**). **NOTE:** Be sure to install left and right hand gloves on the correct side and position them with thumbs upward.
8. From the outside, install the Air Input Regulating Disk (LL) over the six hole array on the upper rear corner of the Cabinet Back Panel (C) and secure with Knob Screw (MM) (**FIG. 17**).
9. From the inside, install the Vacuum Elbow (SS) with grommet. Next, install the Vacuum Baffle (X) over the vacuum hole on the upper left corner of the Cabinet Back Panel (C) and secure with 4 M6 x 12mm screws (AA) and nuts (EE) (**FIG. 17**).



4 Pcs. AA M6 x 12mm Screw 

4 Pcs. EE M6 Nut 

1 Pc. SS Vacuum Elbow 



1. Install Latches (M) to the upper corners of the Cabinet Front Panel (H) and secure with 4 M4 x 10mm screws (CC), flat washers, (GG) & nuts (FF) (FIG. 17).
2. Peel away protective paper and apply Sealing Foam (KK) on the exposed level flange areas on the top of the Cabinet Side Panels (E) and (I) and along the top edge of the Cabinet Back Panel (C) (FIG. 18). **NOTE:** Be sure that no gaps exist between sections of sealing foam.
3. Attach 2 Lamp Clips (HH) to underside of Cabinet Top (D) with 2 M4 x 6mm screws (DD), flat washers (TT) and nuts (FF) (FIG. 19).

2 Pcs. DD M4 x 6mm Screw 

2 Pcs. TT M4 Washers 

2 Pcs. FF M4 Nut 


4. Snap Fluorescent Lamp (QQ) into Lamp Clips (HH) and secure with 2 Cable Ties (II) (FIG. 19).
5. Route the cord of the Fluorescent Lamp (QQ) through the hole in the upper area of Cabinet Side Panel (E) then thread the cord ferrule into the hole (FIG. 19).
6. Connect the Fluorescent Lamp (QQ) wires to the Switch (F) wires. Attach Blue Wire to Blue wire connection and Brown Wire to the Brown wire connection (FIG. 19). **NOTE:** Needle Nose pliers may be useful for inserting wires to switch connection.
7. Attach Switch (F) to Cabinet Side Panel (E) with 2 M4 x 10mm screws (CC), washers (GG) and nuts (FF) (FIG. 19). **NOTE:** Be sure to position the switch facing forward towards operator.

2 Pcs. CC M4 x 10mm Screw 

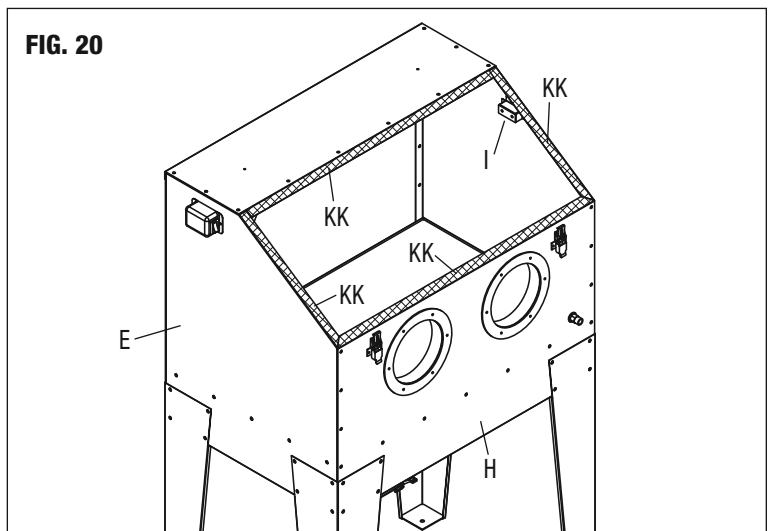
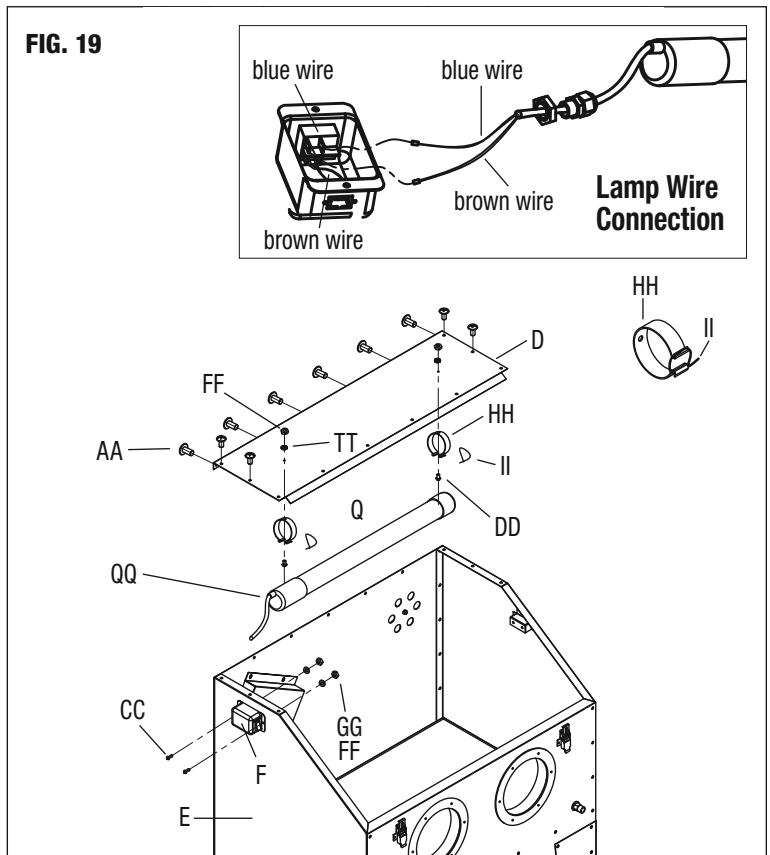
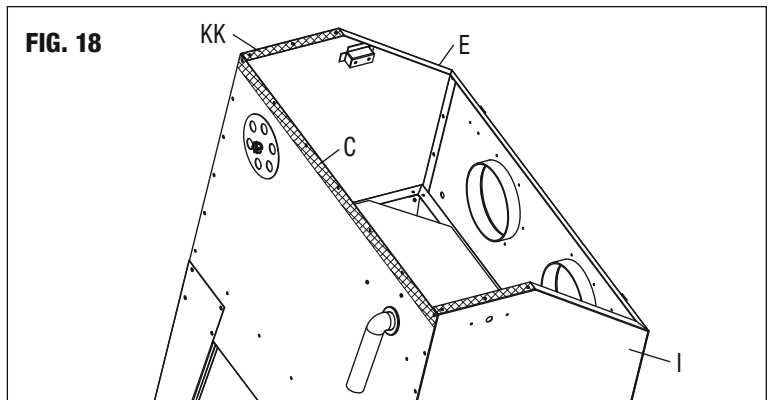
2 Pcs. GG M4 Washers 

2 Pcs. FF M4 Nut 

8. Peel away protective paper and apply **Thick** Sealing Foam (KK) on the remaining exposed angled flange areas on the opening of the Cabinet Assembly (FIG. 20). **NOTE:** Be sure that no gaps exist between sections of sealing foam.
9. Attach Door (A) hinge plate to the Cabinet Top (D) with 6 M6 x 12mm screws (AA) and nuts (EE) (FIG. 20). **NOTE:** Do not let door fall backward against top or glass window breakage will result.

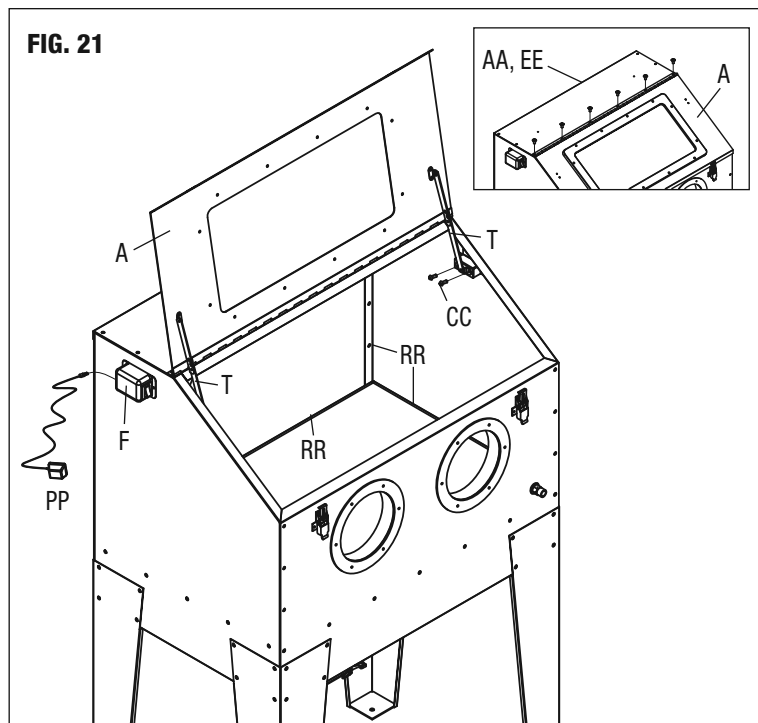
6 Pcs. AA M6 x 12mm Screw 

6 Pcs. EE M6 Nut 



1. Install 2 Door Supports (T) to the Cabinet Side Panels with 4 M4 x 10mm screws (CC) (FIG. 21).
2. Attach Door Supports (T) to the Door (A) with 4 M4 x 10mm screws (CC) (FIG. 21).
3. Plug the Transformer (PP) connector into the Switch (F) (FIG. 21).
4. Apply a liberal amount of RTV Sealer (RR) to ALL interior joints containing Sealing Foam (KK). While wearing a disposable glove, use index finger to spread the sealer evenly all along the joints to guarantee sealing (FIG. 21).
24. The interior side of tempered glass window of the Door (A) is equipped with a replaceable, peel-off, self-adhesive flexible window shield. It will become cloudy with use. To replace, first peel off worn shield and then gently clean glass with a soft cloth and glass cleaner or alcohol. Peel off adhesive protective strips and apply replacement shield to interior glass surface. Press on adhesive areas to ensure an abrasive proof seal.

CONGRATULATIONS! YOUR FULLY ASSEMBLED EASTWOOD BLAST CABINET IS NOW READY TO BE FILLED WITH MEDIA AND PUT TO WORK!



SET-UP CABINET FOR USE

- The inlet air supply must have a moisture separator capable of removing all moisture and impurities from the air supply. Moisture and/or oil in the air supply will cause clumping and clogging of the media.
- A suitable regulator must be used to limit incoming air pressure to 90 PSI maximum, 80 PSI is ideal. Excessive air pressure can cause permanent damage to the unit.
- For best results, a heavy-duty type vacuum with 1.0 to 2.0 peak horsepower is recommended.
- Slip the hose over the Vacuum Elbow at the rear of the cabinet.
NOTE: Only a light amount of negative pressure needs to be generated in order to keep a dust cloud from forming in the cabinet.
- To adjust airflow, close cabinet door and turn on the vacuum. There should be sufficient negative pressure in the cabinet to cause the blast gloves to “balloon” slightly. If they lift up and stick straight into the cabinet, there is too much vacuum. If they do not balloon and just lie flat, there is not enough. Rotate the Air Input Regulating Plate to adjust vacuum.
- **Never** operate the blast cabinet without a properly filtered shop-type, dust collecting vacuum. If dust is seeping out of your vacuum filter, stop immediately! This is a serious health hazard and will prematurely damage your vacuum motor. Purchase and install a fine particular filter for your particular brand of shop-type vacuum to capture these dust particles.
- Check the Hopper Drain Door (N) and make sure it is closed tightly.
- Add 25 lbs. of Eastwood approved Blast Media. Up to 50 lbs. may be used. **DO NOT USE SAND IN THIS BLAST CABINET!**
NOTE: for best results and to avoid nozzle clogging, do not use media larger than 60 grit particle size.

TROUBLESHOOTING

PROBLEM	CAUSE	CORRECTION
Insufficient Air to Blasting Gun	Compressor Inadequate	For best results, a compressor capable of at least 10 CFM @ 80-90 PSI is recommended. Lesser output will result in diminished performance.
	Air Line from Compressor Too Small	Use air supply line of 5/16" or larger.
	Air Line from Compressor Too Long	An air line of 25' maximum is recommended.
	Pinched or Damaged Section of Hose	Replace suction hose. Automotive fuel or heater hose works well.
Media Surging	Moisture in Media and/or Air Supply	Install a moisture separator capable of removing all moisture and impurities from the air supply.
	Dirt or Blasting Residue in Gun Nozzle	Clean out gun nozzle, then drain and sift blast media to remove debris before re-use.
	Excessive Media in Hopper	For best results, operate blaster with the media suction tube buried several inches in media. 25 lbs. of media is generally sufficient.
Media Stream Suddenly Stops	Dirt or Debris in Suction Hose	To dislodge blockage, place a gloved finger over the nozzle outlet and momentarily depress trigger.
	Media is Contaminated	Drain and sift blast media to remove debris before re-use.
View in Cabinet Becomes Obstructed	Vacuum May Not be Operating Correctly	If dust cloud is present, check to see that vacuum system is functioning properly and the Air Inlet Regulating Plate is adjusted per instructions.
	Lens Shield is Worn	Clean inside of window and replace peel-off lens shield.

ACCESSORIES

- #30998 Dust Collection System
- #22022 Blast Media Sifter Screen
- #20608 Filter/Regulator Unit with Gauge
- #22019 Silicon Carbide Media, 60 Grit
- #22021 Aluminum Oxide Media, 60 Grit
- #13792 Aluminum Oxide Media, 90 Grit
- #22018 Walnut Shell Media, 12/20 Grit
- #13779 Ground Glass Media, 40/70 Grit
- #13772 Glass Bead Media, 100/170 Grit
- #22023 Glass Bead Media, 70/100 Grit
- #11806 Soda Media, 10 lbs.
- #20068 Replacement Nozzles, 4pc
- #20071 22" x 10-1/2" Window Liners, 5pc

If you have any questions about the use of this product, please contact

The Eastwood Technical Assistance Service Department: 800.544.5118 >> email: techelp@eastwood.com
 PDF version of this manual is available online >> eastwood.com/20027manual

The Eastwood Company 263 Shoemaker Road, Pottstown, PA 19464, USA
 US and Canada: 800.345.1178 Outside US: 610.718.8335
 Fax: 610.323.6268 eastwood.com