

Eastwood

DO THE JOB RIGHT.

Item #20267

BEAD ROLLER FORMING DIE SET

INSTRUCTIONS



The **Eastwood Bead Roller Forming Die Set** is an exclusive Eastwood in-house engineered die set designed by experienced metal craftsmen for experienced metal craftsmen for fabricating custom panels and complex metal parts. Create hemmed edges, style lines, offsets, deep channels, radiused contours and other intricate forms in steel and aluminum. Fits the Eastwood Bead Roller (#28187) and other units with 22mm shafts.

INCLUDES

- | | |
|---|---------------------------------------|
| (1) Polyurethane Lower Wheel (A) | (1) Lower Edge Forming Die (F) |
| (1) 180 Lower Die (B) | (1) 3/8" Tipping Die (G) |
| (1) Inside Offset Die (C) | (1) 1/2" Tipping Die (H) |
| (1) Outside Offset Die (D) | (1) Round Tipping Die (I) |
| (1) Knife Edge Tipping Die (E) | (1) Lower Forming Die (J) |

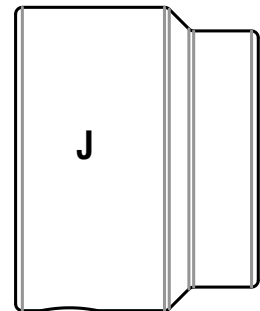
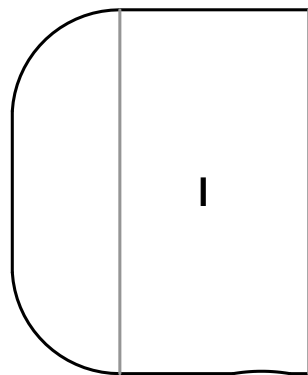
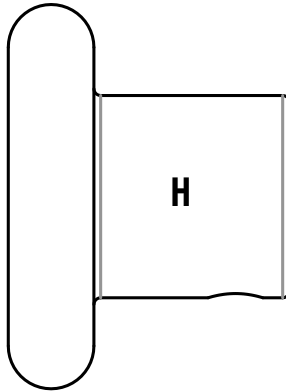
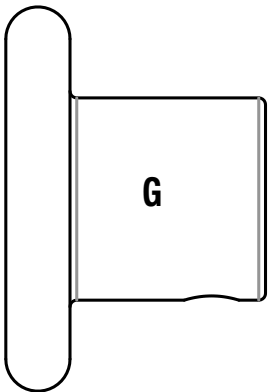
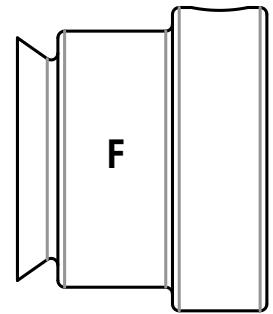
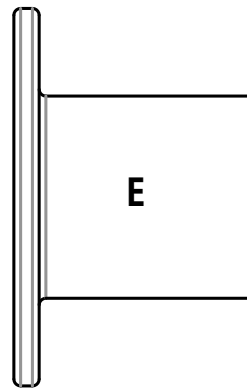
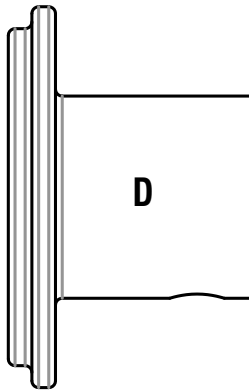
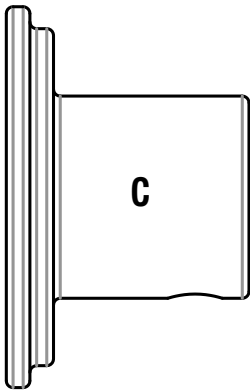
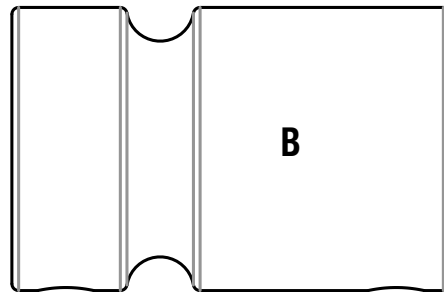
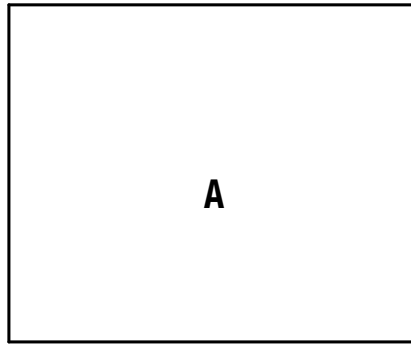

SPECIFICATIONS

- Material = CR12
- Hardness = 30-40 HRC

SAFETY INFORMATION



READ INSTRUCTIONS!

Thoroughly read and understand this instruction manual before using. Save manual for future reference.



INJURY HAZARD!

- **WARNING! The Bead Roller has rotating rollers and gears with amplified leverage which can quickly cause severe injury!** Keep fingers and hands away from moving parts when operating.
- Wear thick, well fitting work gloves to prevent cuts from handling sharp metal.
- Frequently inspect moving parts and structure of the Bead Roller. If damage is observed, discontinue tool use immediately.
- Make sure the Bead Roller Frame is securely mounted in a minimum 4" (6" & larger strongly recommended) vise properly fastened to a solid work surface before use. **IMPORTANT NOTE:** The Eastwood Bead Roller is moderately heavy, have a helper available when installing in the vise.

EXAMPLES OF METAL CONTOURS THAT CAN BE CREATED WITH DIE COMBINATIONS:

The following images illustrate only some of the many contour configurations that can be created in metal by combining the dies in this kit. The resilient composition of the "A" Polyurethane Die offers mar-free backup for any Eastwood Die and allows for the creation of virtually any metal shape imaginable.

TIP: Experiment with material that is close in thickness to the gauge of metal you wish to use. This will enable you to determine the metal contour that will result from your experimental combination. **Visit eastwood.com to view a video on how to use each die.**

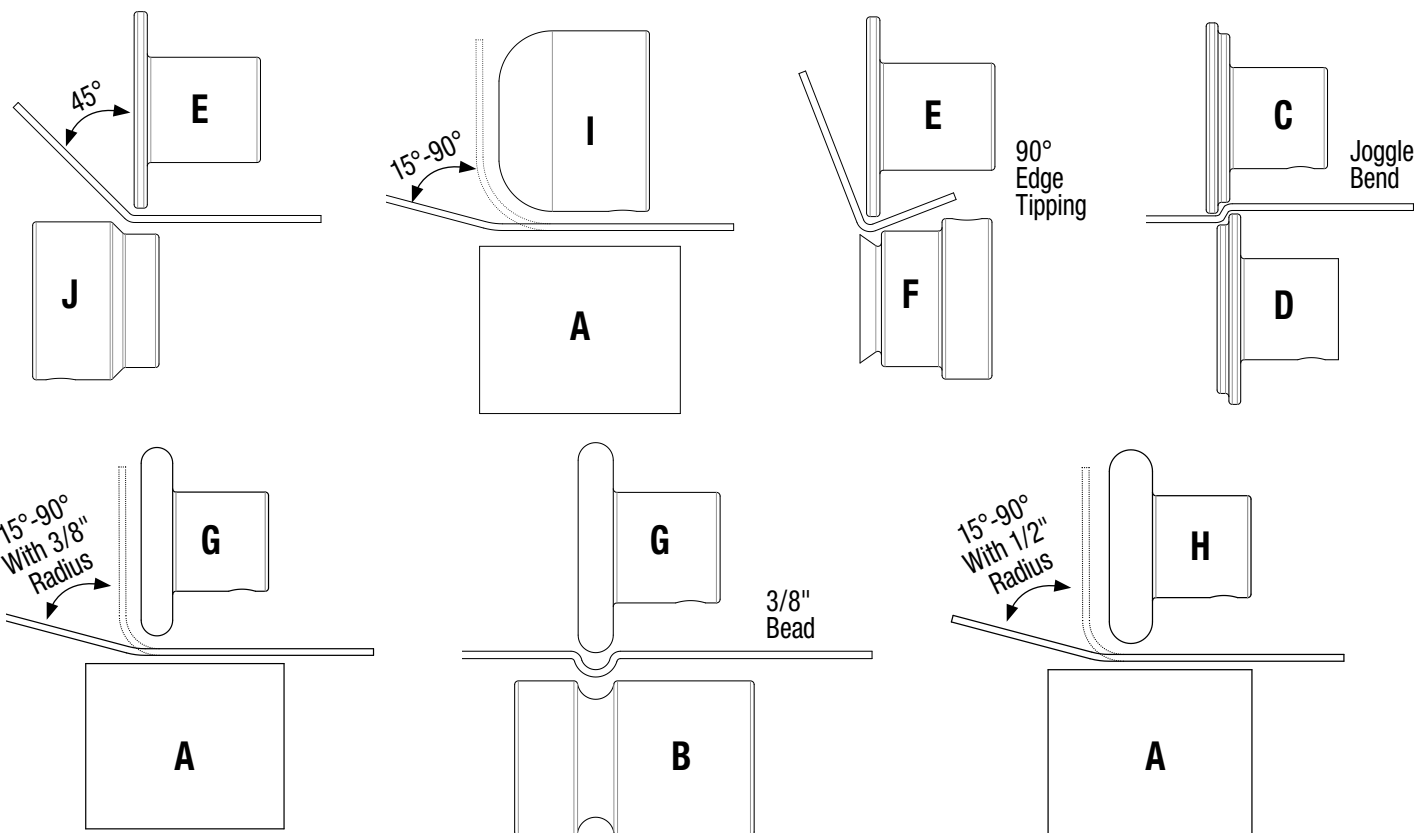
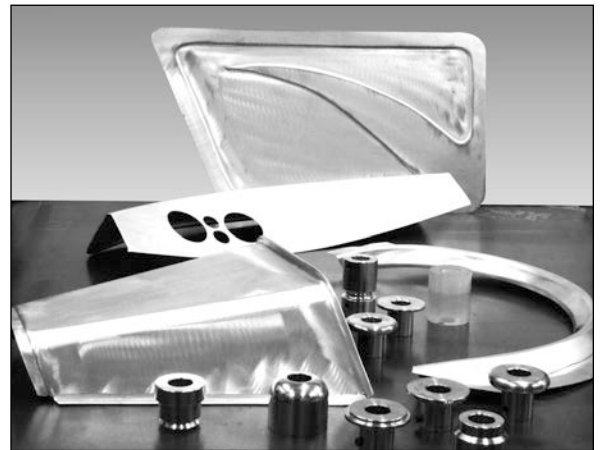

LAYOUT & PLANNING

- Using a suitable marker, draw the pattern or shape you want to form with beads right on the panel. We recommend using a T-square and straightedge or long ruler for straight lines (**Fig A**). For curves, use a circle or radius template.
- Work carefully and lay out your design lines as neatly as possible.
- When forming beads, be sure to work from the inside of the piece toward the outside. The bead roller shrinks metal and if you work from the outside toward the center, the bead you previously formed will be distorted and the entire piece may warp.
- Plan out how you will need to turn and move the panel while creating the pattern to avoid having to start and stop in the middle of a line.
- A little time taken at this stage will make the rest of the job go more easily & help avoid mistakes.

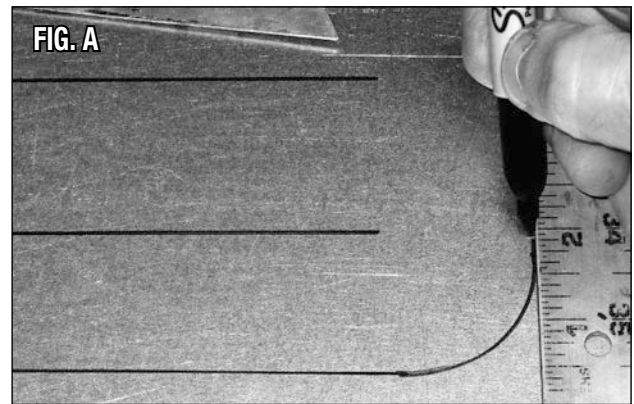

OPERATION

- Loosen the 2 Upper Bearing Block bolts located at the rear of the Bead Roller Frame with a 19mm wrench (not included) (**Fig B**).
NOTE: the Left upper Bearing Block mounting hole is slotted.
- Loosen the Roller Tensioning Bolt with a 10mm wrench (not included) and retract it several turns (**Fig C**). At this point, the Left side of the Upper Roller Shaft and Bearing Block should be free to be raised up sufficiently to separate the Bead roller Mandrels enough to slide the workpiece metal between them.
- Center the Upper Die over the previously drawn pattern line then slide the Upper Roller Shaft and Bearing Block down in place against the metal workpiece panel (**Fig D**).
- Draw down the Roller Tensioning Bolt finger tight, check alignment with your drawn line then tighten several additional turns with a 10mm wrench (not included) (**Fig E**). **CAUTION:** Do Not Over tighten as this may tear the metal workpiece, jam the Roller Dies or deform the Frame.
- Tighten the Upper Bearing Block bolts located at the rear of the Bead Roller Frame with a 19mm wrench (not included) (**Fig F**).

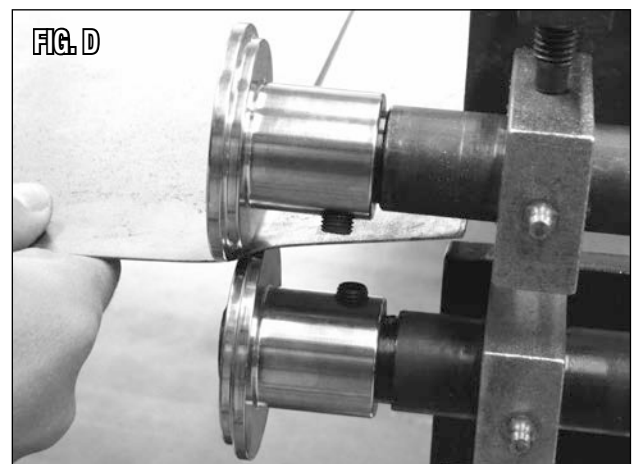
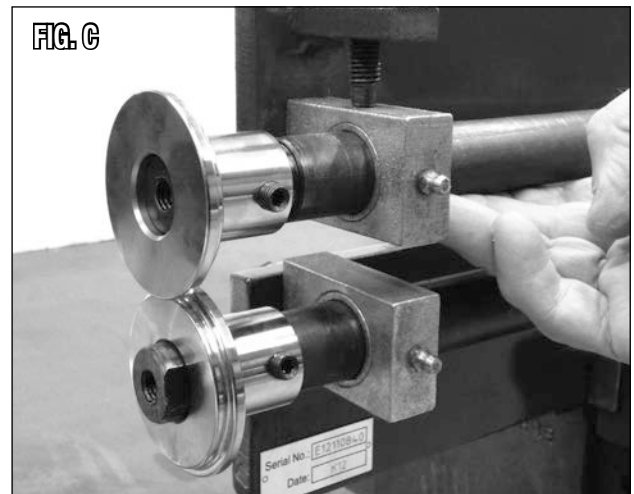
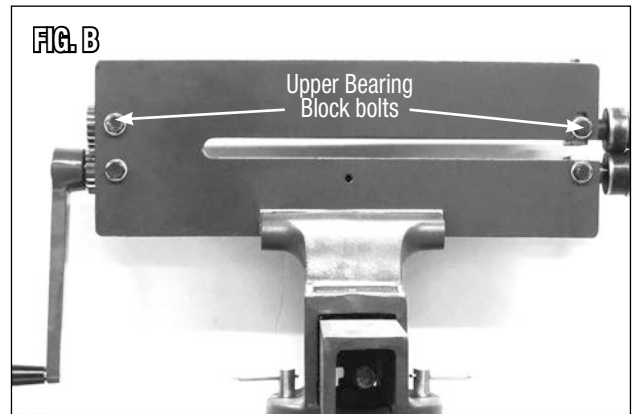

- **IMPORTANT NOTE:** For the greatest ease in handling workpiece panels and achieving optimal accuracy in forming beads, it is strongly advised to have a helper turning the handle as you work.
- Have the helper crank slowly as you move the metal along following your marked guideline (**Fig G**).
- Keep the marked guideline aligned with the center of the Upper Female Mandrel Die groove as you go. When you reach the end of the guideline, you may re-roll the bead by having your helper turn the crank in the opposite direction. This produces a more sharply defined bead.
- When done, loosen and retract the Roller Tensioning Bolt then loosen the Upper Bearing Block bolts located at the rear of the Bead Roller Frame with a 19mm wrench (not included).
- It is critical to producing a good job that you keep the guideline aligned with the center of the Upper Female Mandrel Die groove as you go (**Fig H**). If your design forms an oval, start the bead in the center of a straight or larger radiused section.
- Do no attempt to start right at a corner or a joint of two lines, since it will be extremely difficult to line up the bead perfectly when you finish.
- By using combinations of curves and straight lines, there is almost no limit to the designs you can create with the Eastwood Bead Roller.
- Pull the workpiece panel from between the dies and admire your work.

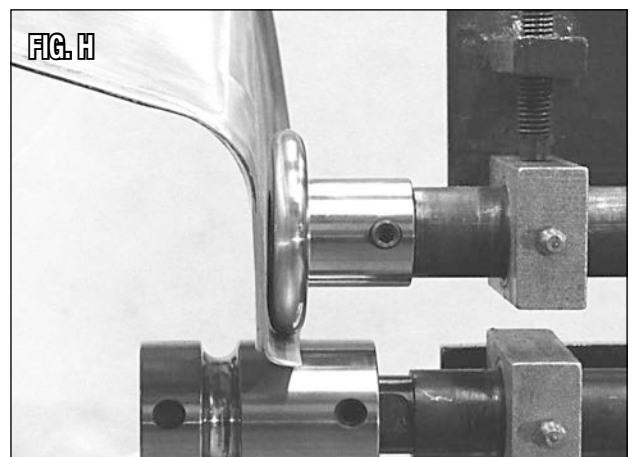
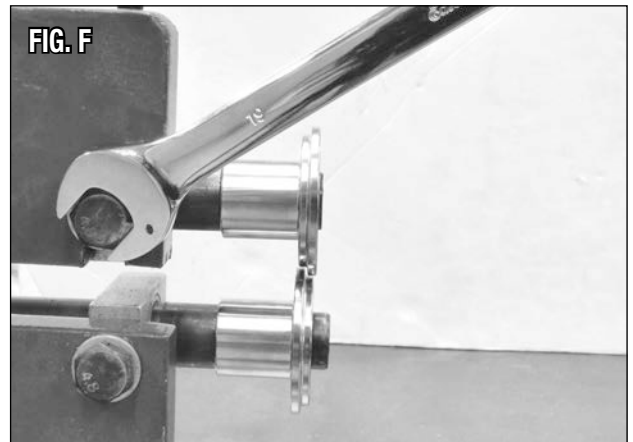
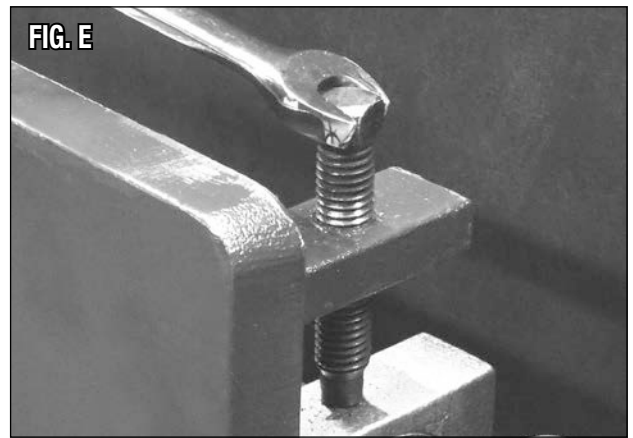

DISMOUNTING & MOUNTING BEAD ROLLER MANDREL DIES

MANDREL DIE REMOVAL

- Loosen the 2 Upper Bearing Block bolts located at the rear of the Bead Roller Frame with a 19mm wrench (not included) (**Fig I**). Note that the Left upper Bearing Block mounting hole is slotted. Allow the upper Mandrel Die to rest on the lower one temporarily and with the drive gear teeth engaged, hold the Crank Handle to keep the shafts from turning. With a 16mm wrench, (not included) loosen and remove the (2) Mandrel Die Cap Screw Bolts (**Fig J**).
- Loosen the 4mm Mandrel Die setscrews with a 4mm hex key (not included) (**Fig K**).
- Pull the Mandrel Dies from the shafts (**Fig L**).

MANDREL DIE INSTALLATION

- Raise the upper shaft slightly and slide the Mandrel Dies onto the shaft ends. Be sure to align the set screws with the flats of the shafts.
- Use care to align the machined grooves or offsets of the Mandrel Dies before tightening set screws.
- Note that the Polyurethane Lower Wheel (**Fig C**) is a slip fit on the lower shaft and has no set screws.
- Adjust the 2 Upper Bearing Block Bolts and Roller Tensioning Bolt as required.

STORAGE

MANDREL DIE REMOVAL

- Apply a thin film of light oil or rust-preventive to all bare steel areas.
- Store in a clean, dust-free, dry, area preferably covered with plastic.

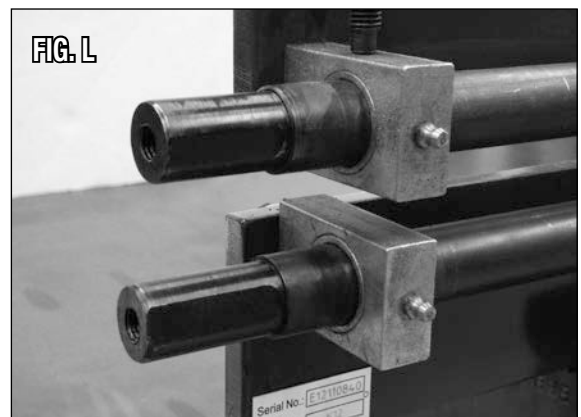
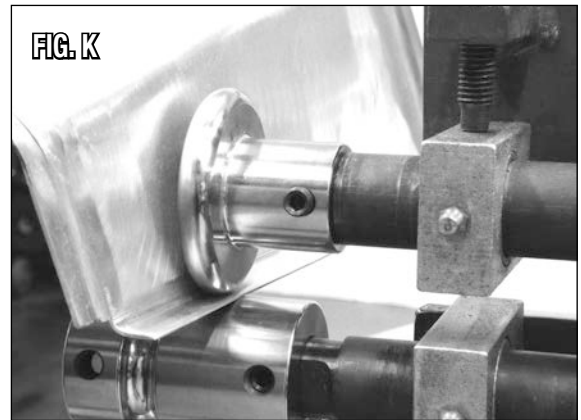
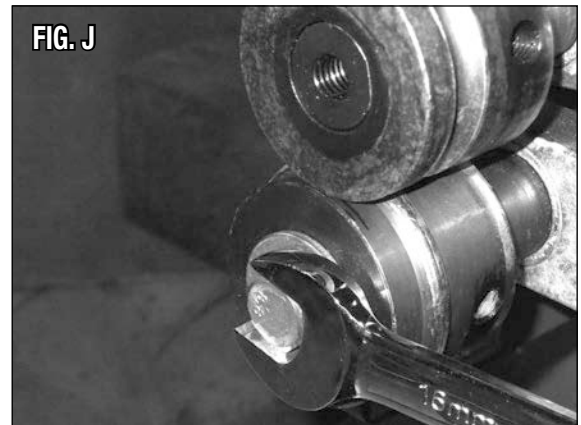
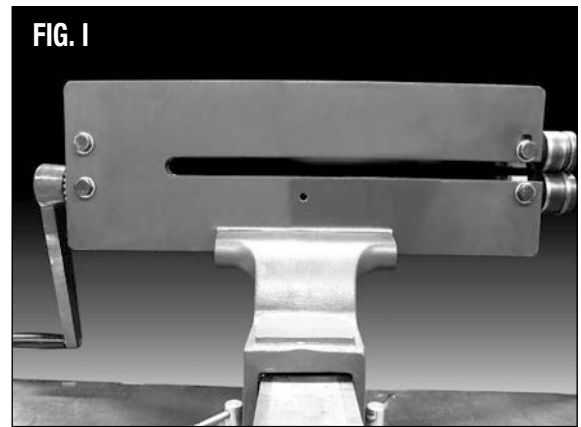

ACCESSORIES

- # 28060P Adjustable Guide Fence guides along the edge of a metal panel and allows you to make straight line beads perfectly straight and parallel
- # 51088 Shrinker/Stretch Set
- # 13475 Eastwood Electric Metal Shears
- # 11797 Throatless Shear
- # 14042 Versa Bend Sheet Metal Brake
- # 20254 Eastwood 24" Slip Roll
- # 20268 Replacement Polyurethane Lower wheel

If you have any questions about the use of this product, please contact

Eastwood Technical Assistance Service Department: 800.544.5118 >> email: techelp@eastwood.com

PDF version of this manual is available online >> eastwood.com/20267manual

The Eastwood Company 263 Shoemaker Road, Pottstown, PA 19464, USA

US and Canada: 800.345.1178 Outside US: 610.718.8335

Fax: 610.323.6268 eastwood.com