

Eastwood

DO THE JOB RIGHT.

Item #20411

VERSA-BEND FORMING BRAKE INSTRUCTIONS



The **Eastwood Versa-Bend Forming Brake** is designed to be used with the Eastwood #14042 Versa-Bend 20" Sheet Metal Brake to create multiple bend channel shapes as narrow as 3/8" (9.5mm) in mild, 20 gauge sheet steel and 18 gauge aluminum panels up to 20" wide. Excellent for creating hard to form parts such as window channels, floor braces, weatherstrip retainers and much more.

SAFETY INFORMATION



READ INSTRUCTIONS!

Thoroughly read and understand Eastwood #14042 Versa-Bend 20" Sheet Metal Brake manual before using the Brake tool.



WARNING!

- **WARNING! This tool has pinch points with amplified leverage which can quickly cause severe injury!**
Keep fingers and hands away from moving parts when operating.
- Wear appropriate work gloves and protective clothing. Sheet metal will often have sharp edges which can cause cuts to hands and arms.
- The Eastwood #14042 Versa-Bend 20" Sheet Metal Brake is considerably heavy. Use extreme caution when mounting or dis-mounting when using a vice or other temporary fixturing arrangement. Personal injury could occur if tool is dropped.
- Wear appropriate eye protection. Metal chips can be ejected during the bending process.



INCLUDES

- (1) Eastwood Versa-Bend Forming Brake
- (2) 10mm x 1.5 x 60mm Bolts
- (2) 10mm washers

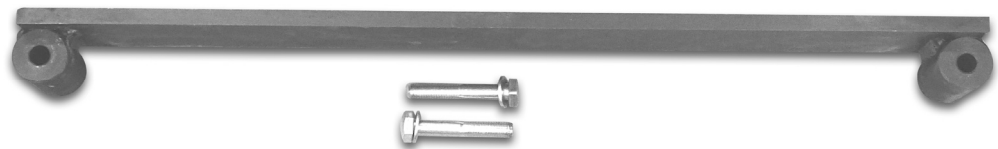

SET-UP

CAUTION! Standard Clamping Beam is heavy and may cause personal injury if dropped. Use care to support it during removal.

- Remove the standard Clamping Beam from the Eastwood #14042 Versa-Bend 20" Sheet Metal Brake.
- Place the Eastwood Versa-Bend Forming Brake on the deck of the Sheet Metal Brake. Be sure the face of the Forming Brake is oriented toward the face of the pivoting Bending Bar (**FIG A**).
- Place the two 10mm x 1.5 x 60mm Hold-down Bolts with washers through the cylindrical ends of the Forming Brake then thread them in finger tight (**FIG A**).

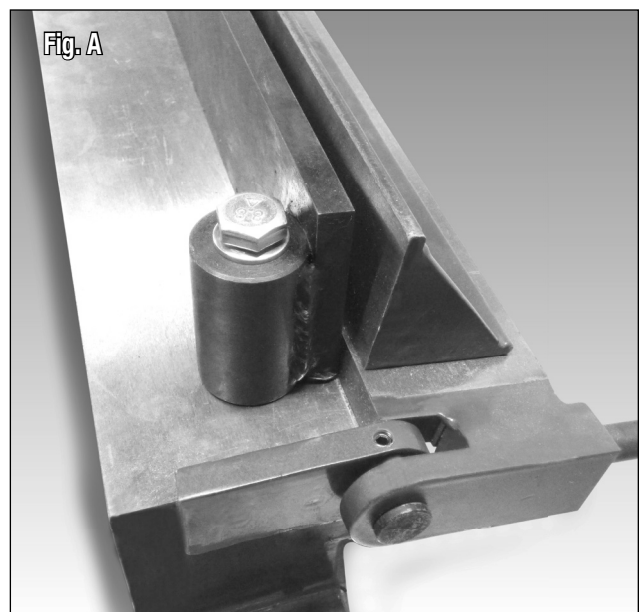

OPERATION

NOTES:

- It is strongly recommended to make a mockup of your final piece in heavy construction paper or manila folder material prior to beginning as it is very easy to make a mistake and create a bend in the wrong direction.
- Follow the Eastwood #14042 Versa-Bend 20" Sheet Metal Brake instructions carefully while using the Eastwood Versa-Bend Forming Brake.

STANDARD 1ST BENDS UP TO 90°

With the Eastwood Versa-Bend Forming Brake in place, conventional bends can be made in 20 gauge mild steel panels up to 20" and in 18 gauge in widths of 12" or less.

- Measure and mark the desired bend line on your sheetmetal panel.
- Loosen the 10mm x 1.5 x 60mm Hold-down Bolts with a 17mm wrench.
- Slide metal panel under the Forming Brake lining up your pre-marked bend line with the lower, beveled edge of the Forming Brake. **NOTE:** this edge is set back slightly from the main body of the brake to allow for a sufficient bend radius of the metal and the most accurate bends.
- Tighten the Forming Brake Hold-down Bolts to hold the panel in place with a 17mm wrench.
- Grasping both handles of the moveable Bending Bar, lift upward, bending your panel until the desired bend angle is achieved. **NOTE:** The use of an angle gauge or protractor (not included) is recommended.

SECONDARY BENDS UP TO 90°

- Measure and mark the desired bend line on your sheetmetal panel.
- Loosen and remove the 10mm x 1.5 x 60mm Hold-down Bolts with a 17mm wrench.
- Lift Forming Brake.
- Set metal panel in place (**FIG B**).
- Replace Forming Brake and align bending mark on metal panel with Beam.
- Tighten the Forming Brake Hold-down Bolts to hold the panel in place. Complete your bend as required (**FIG B**).
- Repeat the above steps as often as necessary to achieve final results.

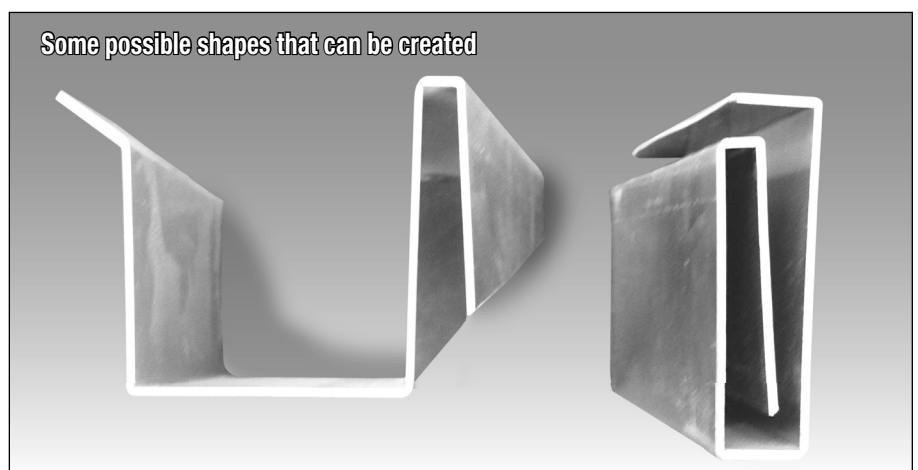
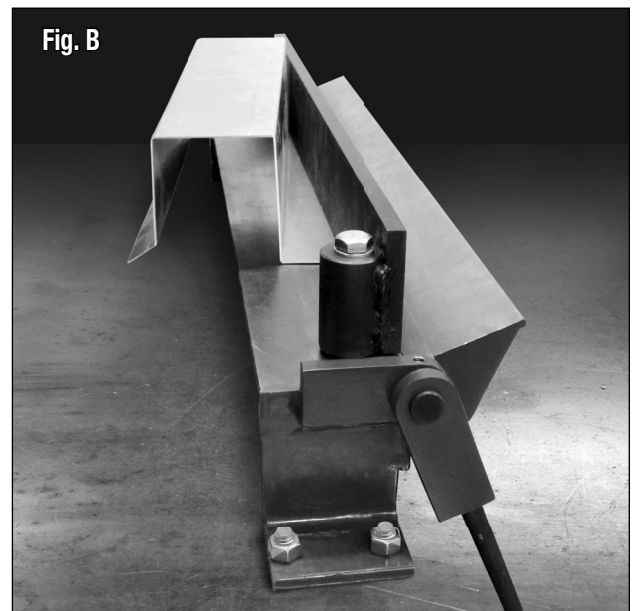

If you have any questions about the use of this product, please contact

The Eastwood Technical Assistance Service Department: 800.544.5118 >> email: techelp@eastwood.com
PDF version of this manual is available online >> eastwood.com/20411manual

The Eastwood Company 263 Shoemaker Road, Pottstown, PA 19464, USA
US and Canada: 800.345.1178 Outside US: 610.718.8335
Fax: 610.323.6268 eastwood.com