

Eastwood[®]

DO THE JOB RIGHT.[®]

Part #20521

4" METAL BENDER

INSTRUCTIONS



The **EASTWOOD 4" METAL BENDER** is a high quality, industrial style tool capable of generating a powerful 2-1/2 tons of pressing force to create 90° or lesser repeatable bends in mild steel and aluminum up to 4" wide.

INCLUDES

- (1) Metal Bending Brake Unit - [A]
- (1) Male Die – [B]
- (1) Handle – [C]
- (1) Acorn Nut - [D]
- (1) Stop Rod – [E]
- (1) Stop Rod Lock Nut – [F]
- (1) Workpiece Stop Gauge – [G]
- (1) Stop Clamping Screw - [H]
- (1) Stop Clamping Wingnut - [I]

SPECIFICATIONS

- Maximum Jaw Travel: 2-1/2"
- Minimum Bend Radius: 1/4"
NOTE: For mild steel only. High carbon steel and stainless steel allowable thickness will be less while aluminum thickness will be higher.
- Maximum Bend Angle: 90°
- Average Maximum Expected Material Bending Capability.
NOTE: Material thicknesses shown are for mild steel only. High carbon steel and stainless steel thickness will be less while aluminum thickness will be higher.
 - 3/4" wide, max. = 3/8" thick
 - 2" wide, max. = 1/4" thick
 - 4" wide, max. = 3/16" thick

SAFETY INFORMATION

The following explanations are displayed in this manual, on the labeling, and on all other information provided with this product:

DANGER

DANGER indicates a hazardous situation which, if not avoided, will result in death or serious injury.

WARNING

WARNING indicates a hazardous situation which, if not avoided, could result in death or serious injury.

CAUTION

CAUTION used with the safety alert symbol, indicates a hazardous situation which, if not avoided, could result in minor or moderate injury.

NOTICE

NOTICE is used to address practices not related to personal injury.

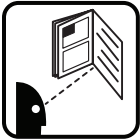

READ INSTRUCTIONS

Thoroughly read and understand this manual before using.
Save for future reference.



WARNING PERSONAL INJURY HAZARD!

- This tool has leveraged rotating components that generate greatly amplified crushing and bending forces which can quickly cause severe injury! Keep fingers and hands away from moving parts when operating.
- Handling sharp metal can cause serious cuts. Wear thick, well fitting work gloves to prevent cuts from handling sharp metal.



WARNING FALL OR INJURY HAZARD!

- Tremendous external torque loads are placed on this Metal Bender during operation. This tool cannot be operated without adequate support or severe personal injury or property damage can occur if it should suddenly become dislodged or moves while in use. Before beginning ANY work with this tool, it is absolutely necessary that it be securely bolted to a heavy, sturdy, anchored workbench.



SAFETY INFORMATION



⚠ WARNING FALL OR INJURY HAZARD!

- Strenuous physical force may need to be applied to the Metal Bender during use. Failure to ensure proper footing can quickly result in a fall which could inflict serious personal injury or property damage. Always work in a clean, uncluttered environment.
- Be sure there is sufficient working room around the tool to allow for safe handling of various lengths of metal.



⚠ CAUTION POSSIBLE EYE INJURY

- Pieces of mill scale, rust and other debris may be ejected from the workpiece during operation. Wear approved eye and skin protection at all times while operating.



⚠ NOTICE POSSIBLE INJURY

- Excessive resistance while operating could indicate a defect with the workpiece material or broken or damaged Metal Bender components. To avoid injury, stop work immediately and inspect workpiece material for nicks, dents, welds, excessive scale or remaining coatings. Clean or repair as necessary or discard and begin with a new piece. Also inspect Metal Bender components for looseness or damage.

ASSEMBLY

⚠ CAUTION

PINCH HAZARD!

The Eastwood Metal Bender consists of moderately heavy metal components which can present a hand/finger pinch hazard and cause potentially serious injuries if dropped on feet. Avoid pinching hands while handling parts during assembly and wear thick, well-fitting work gloves to prevent cuts from handling sharp metal. The use of safety shoes is strongly recommended.

1. Set the Bending Brake Unit [A] on a clean, level work surface.

⚠ WARNING

INJURY HAZARD!

Tremendous external torque loads are placed on this Metal Bender during operation. This tool cannot be operated without adequate support or severe personal injury or property damage can occur if it should suddenly become dislodged or moves while in use. Before beginning ANY work with this tool, it is absolutely necessary that it be securely bolted to a heavy, sturdy, anchored workbench.

2. With the (4) 5/16" [8mm] holes in the baseplate as a guide, mark the locations and centers with a pencil.
3. Drill (4) 5/16" [8mm] mounting holes in work surface. **NOTE:** A minimum thickness of 3/16" steel or 1/2" of a wood-based surface is strongly recommended.
4. Use (4) 5/16" [8mm] bolts (Not Included) washers and nuts to secure baseplate to work surface.
5. Attach Handle [C] to Drive Stem (FIG 1).
6. Thread Acorn Nut [D] onto Drive Stem and tighten securely with a 30mm wrench (FIG 1).

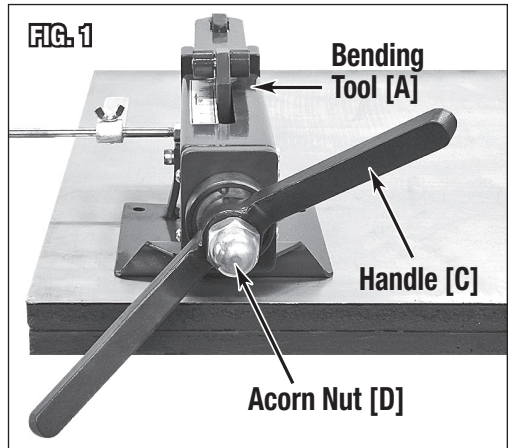
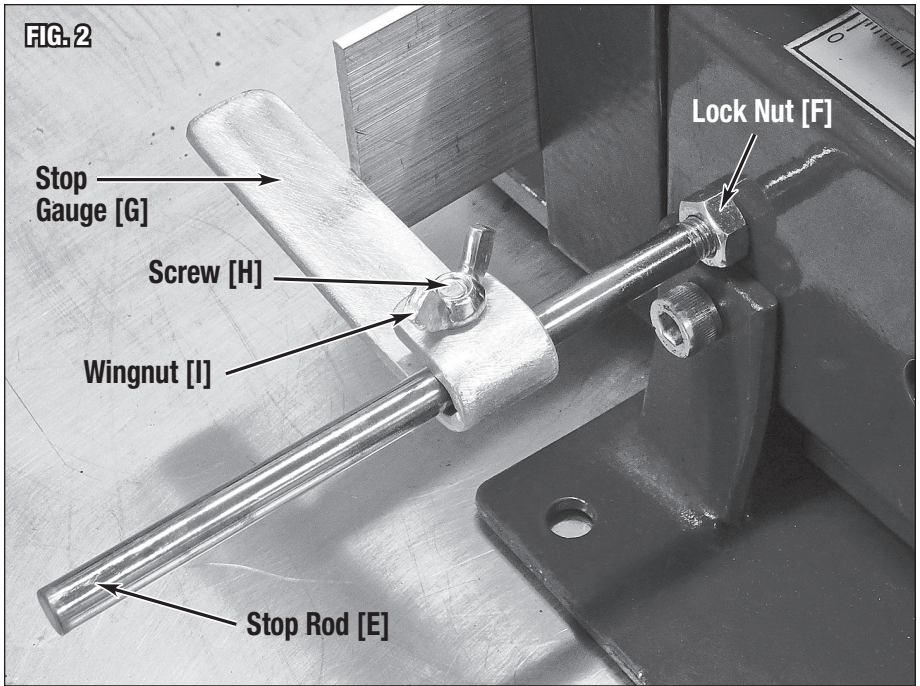

FIG. 2



1. Thread the Stop Rod Locknut [F] onto the Stop Rod [E].
 2. Thread the Stop Rod with Locknut [E,F] into threaded hole in side left side of the Bending Brake Unit - [A] (FIG 2).
 3. Tighten Locknut [F].
 4. Slip Workpiece Stop [G] over Stop Rod [E], place Stop Clamping Screw [H] through hole then thread on Stop Clamping Wingnut [I].
- The Eastwood Metal Bender is now ready to use.

OPERATION

⚠ WARNING

Tremendous external torque loads are placed on this Eastwood Metal Bender during operation. This tool cannot be operated without adequate support or severe personal injury or property damage can occur if it should suddenly be become dislodged or moves while in use. Before beginning ANY work with this tool, it is absolutely necessary that it be securely bolted to a properly anchored heavy, sturdy, anchored workbench.

⚠ CAUTION

The Eastwood Metal Bender exerts tremendous bending and crushing forces in operation which can present a hand/finger pinch hazard and cause potentially serious injuries. Avoid moving parts while operating and wear thick, well-fitting work gloves to prevent cuts from handling sharp metal. The use of safety shoes is strongly recommended.

⚠ CAUTION

The Eastwood Metal Bender was specifically designed to be operated by one person only. Never have one person operate the Handle while one handles the material workpiece or serious injury could occur.

⚠ NOTICE

Workpiece material should be clean of any rust, burrs, nicks, welds or coatings before attempting to bend or interference and binding may occur.

⚠ NOTICE

Apply a minimal amount of a light lubricant to material and die surfaces to ease bending process. Do not over lubricate.

OPERATION

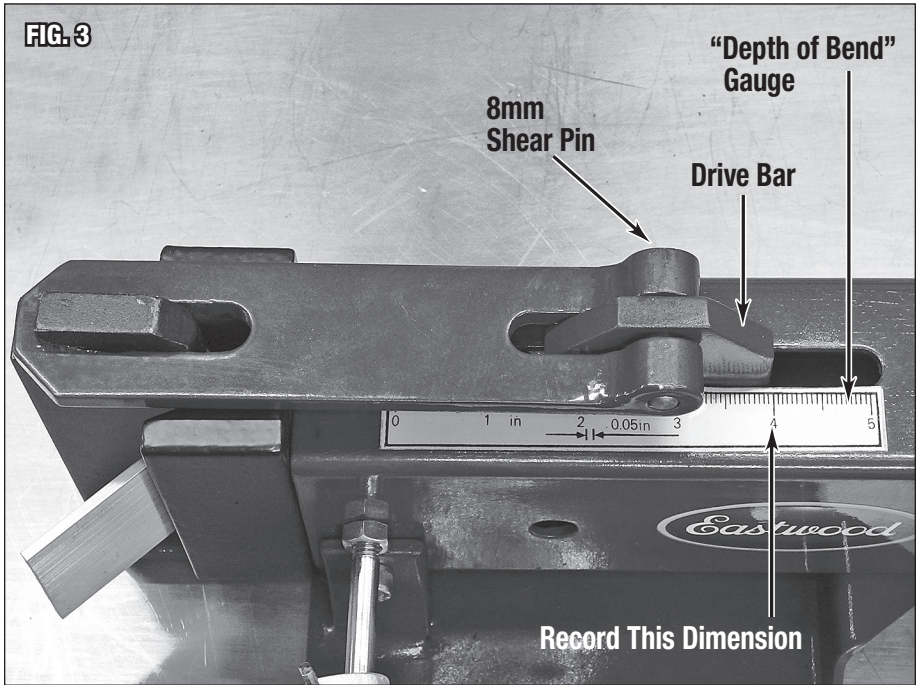

1. Position the workpiece between the jaws then rotate the Handle [C] in a Clockwise direction while holding the workpiece in place with the opposite hand. As the moving Jaw begins to exert pressure on the workpiece, remove your hand from the workpiece and continue to rotate Handle [C] bending the workpiece as you go.
NOTE: The 8mm Shear Pin in the joint of the Drive Bar and Upper link is designed to fail under excess pressure. If replacing, use a softer material 8mm pin or mild steel bolt (FIG 3).
2. As the desired bend is achieved, stop Clockwise rotation and reverse rotational direction of the Handle to release the completed workpiece.

FOR PRODUCING REPEATABLE BENDS

1. To record the depth and angle of bend: Using the gauge located along the slot on top of the tool body, record the dimension aligned at the rear edge of the Drive Bar (**FIG 3**).

▲ NOTICE

There will be a certain amount of “springback” meaning that you must rotate past your gauge target then allow it to “spring back” to the final desired bend angle. This varies widely according to the particular material and thickness being worked. Chromoly and high carbon steel will generally have more “springback” than milder steels and aluminum. This is one reason that some “trial and error” must be performed to explore the properties of the material before working on a final project piece.

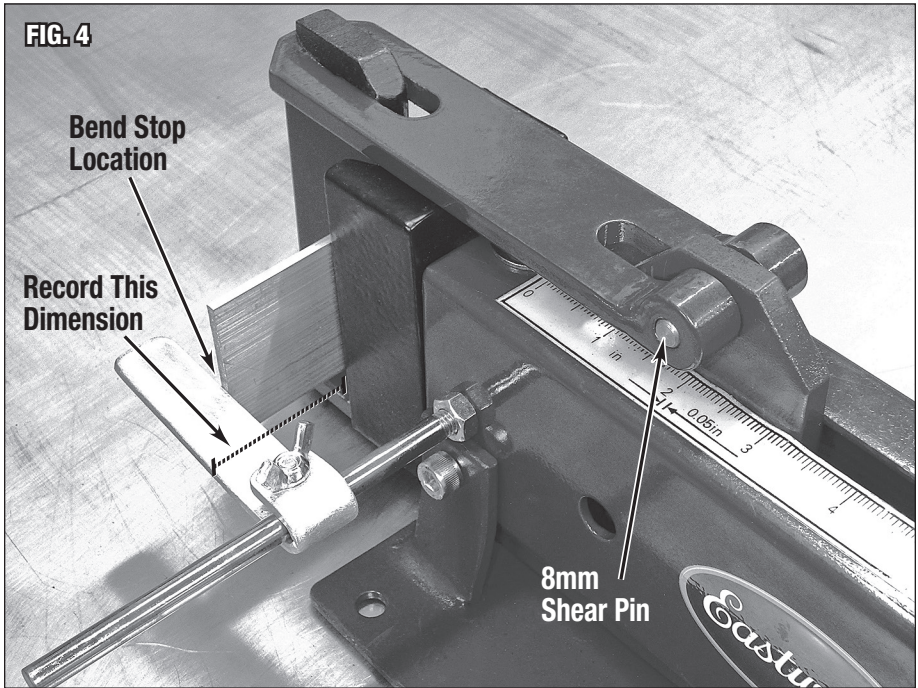

2. **To record the location of bend:** Set the position of the Workpiece Stop Gauge [G] so that the point where the bend is to occur on the workpiece is determined by where the edge of the workpiece contacts the Stop Gauge (**FIG 4**).

STORAGE

- Apply a thin film of light oil or rust-preventive to all bare steel areas.
- Store in a clean, dust-free, dry, dampness free area preferably covered with plastic sheeting.

MAINTENANCE

NOTE: Maintenance should be performed before each use.

- Clean dirt and debris from threaded drive screw.
- Check tightness of all hardware.
- Check operation for binding. Lubricate moving parts and drive screw periodically with medium bodied chassis grease.

NOTE: The 8mm Shear Pin in the joint of the Drive Bar and Upper link is designed to fail under excess pressure. If replacing, use a softer material 8mm pin or mild steel bolt (**FIG 4**).

ADDITIONAL ITEMS

- #51088 Shrinker/Stretcher Set
- #13475 Eastwood Electric Metal Shears
- #11797 Throatless Shear
- #14042 Versa Bend Sheet Metal Brake
- #20254 Eastwood 24" Slip Roll

If you have any questions about the use of this product, please contact

The Eastwood Technical Assistance Service Department: 800.544.5118 >> email: techelp@eastwood.com

PDF version of this manual is available online >> eastwood.com/20521manual

The Eastwood Company 263 Shoemaker Road, Pottstown, PA 19464, USA

US and Canada: 800.345.1178 Outside US: 610.718.8335

Fax: 610.323.6268 eastwood.com