



**DO THE JOB RIGHT.®**

Item #20559

# MP140i WELDER

## INSTRUCTIONS



The **EASTWOOD MP140i WELDER** is designed for use by the serious hobbyist or the busy professional with the versatility to MIG, Stick or TIG weld, all from a single compact, space-saving and lightweight unit for go anywhere convenience. The latest IGBT inverter technology produces the most stable arc possible and provides the capability of welding thin or heavy gauge steel with precision and ease. A powerful, 140-amp maximum welding output allows welding up to 3/16" thick steel and a unique, built-in Spot Weld Timer feature allows precise control for exact, factory perfect spot welds on automotive restoration projects.

For even more versatility and aluminum welding capability, add the optionally available Eastwood Spool Gun.

## READ AND UNDERSTAND ALL INSTRUCTIONS AND PRECAUTIONS BEFORE PROCEEDING.

This unit emits a powerful high voltage and extreme heat which can cause severe burns, dismemberment, electrical shock and death. Eastwood shall not be held liable for consequences due to deliberate or unintentional misuse of this product.

### STATEMENT OF LIMITED WARRANTY

The Eastwood Company (hereinafter "Eastwood") warrants to the end user (purchaser) of all new Eastwood-branded tools and chemicals (collectively called the "products") that each will be free of defects in workmanship and material. This warranty is void if the equipment has been subjected to improper installation, improper care or abnormal operations.

#### WARRANTY PERIOD:

All warranty periods begin on the date of purchase from Eastwood. Warranty Periods are listed below, along with the products covered during those warranty periods:

#### 3-Year Warranty on Material, Workmanship, and Defects:

- Eastwood MIG 135 Welder
- Eastwood MIG 250 Welder
- Eastwood Versa-Cut 20
- Eastwood Versa-Cut 60
- Concours Pro HVLP Paint Gun
- Eastwood TIG 200 DC
- Eastwood MP140i Welder
- Eastwood MP250i Welder
- Eastwood ARC 80 Stick Welder
- Eastwood MIG 175 Welder
- Eastwood TIG 200 Digital
- Eastwood Versa-Cut 40
- Eastwood Rotisserie
- Eastwood TIG 200 AC/DC
- Eastwood MP200i Welder
- Eastwood 90A Flux Core Welder
- Eastwood Contour SCT™

**Items not covered under this warranty:** Consumables, unless deemed defective, are not covered by the 3-year warranty. Abuse, neglect, and lack of maintenance is not covered under this warranty. All other components are covered by the warranty and will be repaired or replaced at the discretion of Eastwood.

#### 2-Year Warranty on Material, Workmanship and Defects:

- Eastwood Air QST-30/60 Scroll Compressor
- Eastwood 60 Gal. 3.7 HP Compressor
- Eastwood Lg View Welding Helmet
- Eastwood 80 Gal. 7.5 HP Compressor
- Eastwood Panoramic Welding Helmet
- Eastwood Auto Darkening Helmet
- Eastwood 80 Gal. 5 HP Compressor
- Eastwood 30 Gal. 1.9 HP Compressor
- Concours 2 HVLP Paint Gun
- Eastwood 60 Gal. 4.7 HP Compressor
- Eastwood XL View Welding Helmet

**Items not covered under this warranty:** Consumables, unless deemed defective, are not covered by the 2-year warranty. Abuse, neglect, and lack of maintenance is not covered under this warranty.

#### 1-Year Warranty on Material, Workmanship and Defects:

- Eastwood Tools Not Included Above
- Fairmount Tools

**Items not covered under this warranty:** Consumables, unless deemed defective, are not covered by the 1-year warranty. Abuse, neglect, and lack of maintenance is not covered under this warranty.

#### 90-Day Warranty on Material, Workmanship and Defects:

- Eastwood Paints & Chemicals
- Rockwood Tools

**Items not covered under this warranty:** Consumables, unless deemed defective, are not covered by the 90-day warranty. Abuse, neglect, and lack of maintenance is not covered under this warranty.

#### Lifetime Warranty on Material, Workmanship and Defects:

- Selected Eastwood Hand Tools carry a Limited Lifetime Warranty

**Items not covered under this warranty:** Abuse, neglect, and lack of maintenance is not covered under this warranty.

#### CONDITIONS TO OBTAIN WARRANTY COVERAGE:

- Proof of purchase must be provided for all warranty claims
- Purchaser must first contact Eastwood at 1-800-343-9353 for an RMA Number before Eastwood will accept any warranty returns. Final determination of warranty on welding and cutting equipment will be made by Eastwood.

**WARRANTY REPAIR:** If Eastwood confirms the existence of a defect covered under this warranty plan, Eastwood will determine whether repair or replacement is the most suitable option to rectify the defect. At Eastwood's request, the purchaser must return, to Eastwood, any products claimed defective under Eastwood's warranty.

**FREIGHT COSTS:** The purchaser is responsible for shipment to and from Eastwood.

#### WARRANTY LIMITATIONS:

EASTWOOD WILL NOT ACCEPT RESPONSIBILITY OR LIABILITY FOR REPAIRS UNLESS MADE BY EASTWOOD. EASTWOOD'S LIABILITY UNDER THIS WARRANTY SHALL NOT EXCEED THE COST OF CORRECTING THE DEFECT OF THE EASTWOOD PRODUCT. EASTWOOD WILL NOT BE LIABLE FOR INCIDENTAL OR CONSEQUENTIAL DAMAGES (SUCH AS LOSS OF BUSINESS, ETC.) CAUSED BY THE DEFECT OR THE TIME INVOLVED TO CORRECT THE DEFECT. THIS WRITTEN WARRANTY IS THE ONLY EXPRESS WARRANTY PROVIDED BY EASTWOOD WITH RESPECT TO ITS PRODUCTS. WARRANTIES IMPLIED BY LAW SUCH AS THE WARRANTY OF MERCHANTABILITY ARE LIMITED TO THE DURATION OF THIS LIMITED WARRANTY FOR THE EQUIPMENT INVOLVED. THIS WARRANTY GIVES THE PURCHASER SPECIFIC LEGAL RIGHTS. THE PURCHASER MAY ALSO HAVE OTHER RIGHTS WHICH VARY FROM STATE TO STATE.



# CONTENTS

- (1) MP140i Multi-Process Welder – P1
- (1) Shielding Gas Regulator – P2
- (1) Shielding Gas Regulator Knob – P3
- (1) Shielding Gas Hose, 4.6' [1.4m] – P4
- (1) Ground Clamp with 10' [3m] Cable – P5
- (1) Trafimet ERGOPLUS 15, Tweeco Style MIG Torch, 10' Length, (0.023"/0.6mm contact tip installed) – P6
- (5) Spare 0.023" [0.6mm] Contact Tips – P7
- (1) Electrode Holder with 12.5' [3.8m] Cable – P8
- (1) TIG Torch with 10' [3m] cable, 14' [4.3m] Gas Line – P9
- (1) #4 Gas Nozzle (1/4") – P10
- (1) #5 Gas Nozzle (5/16") – P11
- (1) #6 Gas Nozzle (3/8") (Installed) – P12
- (1) Short Black Cap (Installed) – P13
- (1) Long Black Cap – P14
- (1) Collet, 1/8" [3.2mm] (Installed) – P15
- (1) Collet, [1.6mm] (Installed) – P16
- (1) Collet, [1.0mm] – P17
- (1) Collet, [2.0mm] – P18
- (1) 1/16" x 6" Tungsten (Gray) – P19
- (1) Welding Wire Spool, 2lb., 0.023" Solid Wire – P20
- (5) Welding Rods, 1/8" E6013 – P21
- (1) 8" Wire Spool Adapter – P22
- (1) Contact Tip Wrench – P23



# SPECIFICATIONS

Input Power	Frequency	Rated Input Current	No-Load Voltage	Rated Working Voltage	MIG Welding Current	TIG Welding Current	Stick Welding Current	Rated Duty Cycle	Enclosure Protection	Cooling Type
VAC	Hz	Amps	V	V	A	A	A	%	IP	-
120	50/60	20	68	18.5	30-140	30-70	30-70	30 @90A	21S	Fan cooled

## MIG WELDING WIRE

	Solid	Stainless	Flux Core
Wire Type and Diameter	0.023-0.035" (0.6-0.9mm)	0.023-0.035" (0.6-0.9mm)	0.030-0.035" (0.8-0.9mm)

## SPOOL GUN WELDING WIRE

	4043 Aluminum
Wire Type and Diameter	0.030-0.035" (0.8-0.9mm)

## ARC WELDING RODS

Type	E6010	E6011	E6013	E7014
Diameter	1/16", 3/32", 1/8"	1/16", 3/32", 1/8"	1/16", 3/32", 1/8"	1/16", 3/32", 1/8"
Polarity	DCEP	DCEN	DCEN, DCEP	DCEN, DCEP

## DUTY CYCLE

The rated Duty cycle refers to the amount of welding that can be done within an amount of time. The Eastwood MP140i has a duty cycle of 30% at 90 Amps. It is easiest to look at your welding time in blocks of 10 Minutes and the Duty Cycle being a percentage of that 10 Minutes. If welding at 90 Amps with a 30% Duty Cycle, within a 10 Minute block of time you can weld for 3 Minutes with 7 Minutes of cooling for the Welder.

If the Duty Cycle is exceeded, the Welder will automatically shut off, however the fan will continue running to cool the components. When a safe temperature has been reached, the Welder will automatically switch the Welder output back on. To increase the duty cycle you can turn down the Voltage Output control.



# SAFETY INFORMATION

Welding can be dangerous to you and other persons in the work area. Read and understand this instruction manual before using your Eastwood welding machine. Injury or death can occur if safe welding practices are not followed.

Safety information is set forth below and throughout this manual.

To learn more about welding safety, read OSHA Title 29 CFR 1910, available at [www.osha.gov](http://www.osha.gov); ANSI Z49.1, "Safety in Welding, Cutting and Allied Processes," available at [www.aws.org](http://www.aws.org); and the consumable manufacturer's Safety Data Sheet.

The following explanations are displayed in this manual, on the labeling, and on all other information provided with this product:

## DANGER

DANGER indicates a hazardous situation which, if not avoided, will result in death or serious injury.

## WARNING

WARNING indicates a hazardous situation which, if not avoided, could result in death or serious injury.

## CAUTION

CAUTION used with the safety alert symbol, indicates a hazardous situation which, if not avoided, could result in minor or moderate injury.

## NOTICE

NOTICE is used to address practices not related to personal injury.

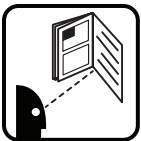

### READ INSTRUCTIONS

Thoroughly read and understand this manual before using. Save for future reference.



### DANGER ELECTRIC SHOCK CAN CAUSE INJURY OR DEATH!

- Improper use of an electric Welder can cause electric shock, injury and death! Read all precautions described in the Welder Manual to reduce the possibility of electric shock.
- Disconnect Welder from power supply before assembly, disassembly or maintenance of the torch, contact tip and when installing or removing nozzles.
- Always wear dry, protective clothing and leather welding gloves and insulated footwear. Use suitable clothing made from durable flame-resistant material to protect your skin.
- Always operate the Welder in a clean, dry, well ventilated area. Do not operate the Welder in humid, wet, rainy or poorly ventilated areas.
- The electrode and work (or ground) circuits are electrically "hot" when the Welder is on. Do not allow these "hot" parts to come in contact with your bare skin or wet clothing.
- Separate yourself from the welding circuit by using insulating mats to prevent contact from the work surface.
- Be sure that the work piece is properly supported and grounded prior to beginning an electric welding operation.
- Always attach the ground clamp to the piece to be welded and as close to the weld area as possible. This will give the least resistance and best weld.



### DANGER WELDING SPARKS CAN CAUSE FIRE OR EXPLOSION!

- Electric welding produces sparks which can be discharged considerable distances at high velocity igniting flammable or exploding vapors and materials.
- Do not operate electric arc Welder in areas where flammable or explosive vapors are present.
- Do not use near combustible surfaces. Remove all flammable items within 35 feet of the welding area.
- Always keep a fire extinguisher nearby while welding.
- Use welding blankets to protect painted and or flammable surfaces; rubber weather-stripping, dash boards, engines, etc.
- If other persons or pets are in the area of welding, use welding screens to protect bystanders from sparks.



**⚠ WARNING ELECTROMAGNETIC FIELDS CAN BE A HEALTH HAZARD!**

- The electromagnetic field that is generated during arc welding may interfere with various electrical and electronic devices such as cardiac pacemakers. Anyone using such devices should consult with their physician prior to performing any electric welding operations.
- Exposure to electromagnetic fields while welding may have other health effects which are not known.



**⚠ WARNING ARC RAYS CAN BURN!**

- Arc rays produce intense ultraviolet radiation which can burn exposed skin and cause eye damage. Use a shield with the proper filter (a minimum of #11) to protect your eyes from sparks and the rays of the arc when welding or when observing open arc welding (see ANSI Z49.1 and Z87.1 for safety standards).
- Use suitable clothing made from durable flame-resistant material to protect your skin.
- If other persons or pets are in the area of welding, use welding screens to protect bystanders from sparks and arc rays.



**⚠ WARNING FUMES AND WELDING GASES CAN BE A HEALTH HAZARD!**

- Fumes and gasses released during welding are hazardous. Do not breathe fumes that are produced by the welding operation. Wear an OSHA-approved respirator when welding.
- Always work in a properly ventilated area.
- Never weld coated materials including but not limited to: cadmium plated, galvanized, lead based paints.



**⚠ CAUTION HOT METAL AND TOOLS WILL BURN!**

- Electric welding heats metal and tools to temperatures that will cause severe burns!
- Use protective, heat resistant gloves and clothing when using Eastwood or any other welding equipment. Never touch welded work surface, torch tip or nozzle until they have completely cooled.



**⚠ CAUTION FLYING METAL CHIPS CAN CAUSE INJURY!**

- Grinding and sanding will eject metal chips, dust, debris and sparks at high velocity. To prevent eye injury wear approved safety glasses.
- Wear an OSHA-approved respirator when grinding or sanding.
- Read all manuals included with specific grinders, sanders or other power tools used before and after the welding process. Be aware of all power tool safety warnings.



**⚠ CAUTION INADEQUATE WIRING CAN CAUSE FIRE AND INJURY!**

- Verify that the facility power source has properly rated wiring to handle power requirements of this Welder.

# CONNECTING THE WELDER TO A POWER SOURCE

The Eastwood MP140i Welder requires a dedicated AC single phase 120V, 50/60HZ, 20 Amp, grounded outlet protected by a circuit breaker. If using an extension cord, use a minimum 12 AWG cord for up to 25 feet.

## CONTROL AND DISPLAY PANEL

The Eastwood MP140i Front Panel is arranged with 5 Function Controls, two Digital Displays and Three LED Indicators (**FIG 1**).

They are as follows:

### FUNCTION CONTROLS

#### A - MIG / TIG / ARC (Stick) & Spool Gun Selector;

3 Position Switch used to select between MIG, TIG or ARC (Stick) welding functionality. Set to Spool Gun for use with optional Spool Gun (not included).

- When set to MIG & Spool Gun Modes; Left Digital Display **[G]** Indicates “Inches Per Minute”. Right Digital Display **[F]** Indicates “Output Voltage”
- When set to Stick/TIG Mode; Left Digital Display **[G]** Indicates “Output Amperage”. Right Digital Display **[F]** Indicates “Output Voltage”

#### B - Spot Weld Timer Power Switch; Turn on to use Spot Weld Function.

- When on; Left Digital Display **[G]** Indicates “Interval in Seconds”. Right Digital Display **[F]** Indicates “Output Voltage”

**C - Spot Weld Timer Interval Control Knob;** Set to preferred Time Interval in Seconds (Indicated on Left Digital Display **[G]**). Limits the length of time in seconds that Torch is energized and automatically shuts it off even though trigger may remain depressed.

**D - Voltage Control Knob;** Controls the voltage output range for MIG (13 to 19 Volts). Voltage value is indicated by the Right Digital Display LED display, **[F]**.

**NOTE:** The Voltage Control Knob serves no function in the Stick/TIG Mode.

**E - Wire Feed / Arc Current Control Knob;** Regulates wire speed in “Inches Per Minute” and Amperage value for Stick and TIG welding.

- Left Digital Display **[G]** Indicates “Inches Per Minute” when Switch **[A]** is set to MIG or Spool Gun.
- Left Digital Display Indicates Amperage Output value when Switch **[A]** is set to Stick/TIG.

### DIGITAL DISPLAYS

**F – Right Digital Display: Voltage Output Digital Display;** Displays MIG & Stick Voltage output value.

**G – Left Digital Display:** (Multi-Function)

- Displays Inches Per Minute when Switch **[A]** is in MIG or Spool Gun Mode.
- Displays Output Amperage when Switch **[A]** is in TIG/Stick Mode.
- Displays Time Interval in Seconds when Switch **[B]** is set to Spot Timer ON.

### LED INDICATORS

**H – Power-On Indicator;** Illuminates GREEN when Welder is connected to a power source and the Power Switch at rear of unit is set to the “ON” position.

**J – Overload Indicator;** Illuminates AMBER when Duty Cycle has been exceeded, the Welder is overloaded or if other abnormalities exist.

**K – Torch Energized Indicator;** Illuminates RED when the Torch Trigger is depressed and the wire (or welding rod) is energized and flowing current.

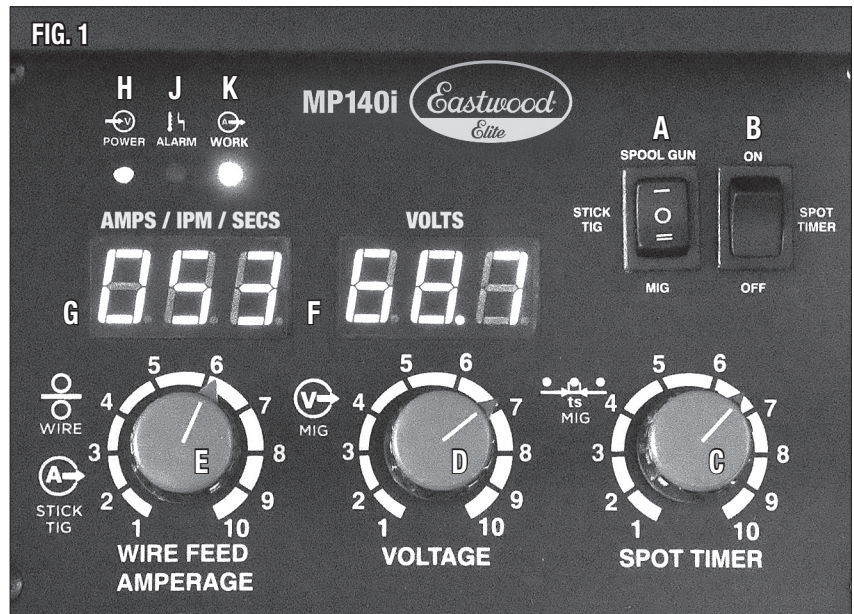



# MIG WELDING SET-UP AND OPERATION

## SET-UP FOR MIG WELDING

### Installing the MIG Welding Gun

- Open the side door of the Welder and loosen the Torch Tensioner Wing Screw located on the side of the brass, hex shaped member of the Drive Motor Assembly (**FIG 2**).
- Plug the Brass Body End of the Welding Gun line into the designated socket (**FIG 3**).  
**IMPORTANT NOTE:** The Brass Body End must be fully seated against the base of the drive assembly socket or gas may either leak or not be able to pass through the connections to the end of the Welding Gun (**FIG 4**).
- Tighten the Torch Tensioner Wing Screw finger tight (**FIG 3**).
- Connect the Male Metal Plug to the Female Cannon Plug connection on the front of the Welder (**FIG 4**).
- Set the Selector Switch **[A]** located on the Front Panel to the MIG Position (**FIG 1**).

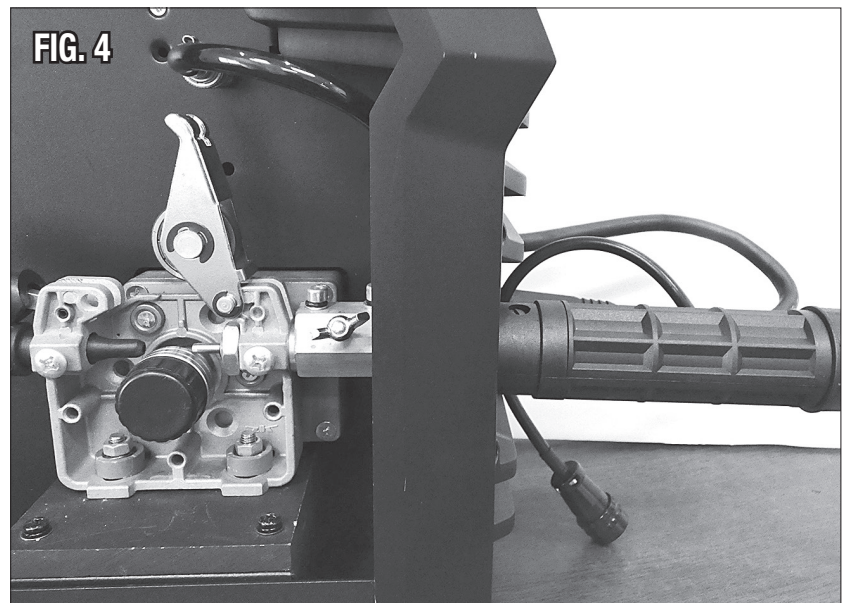
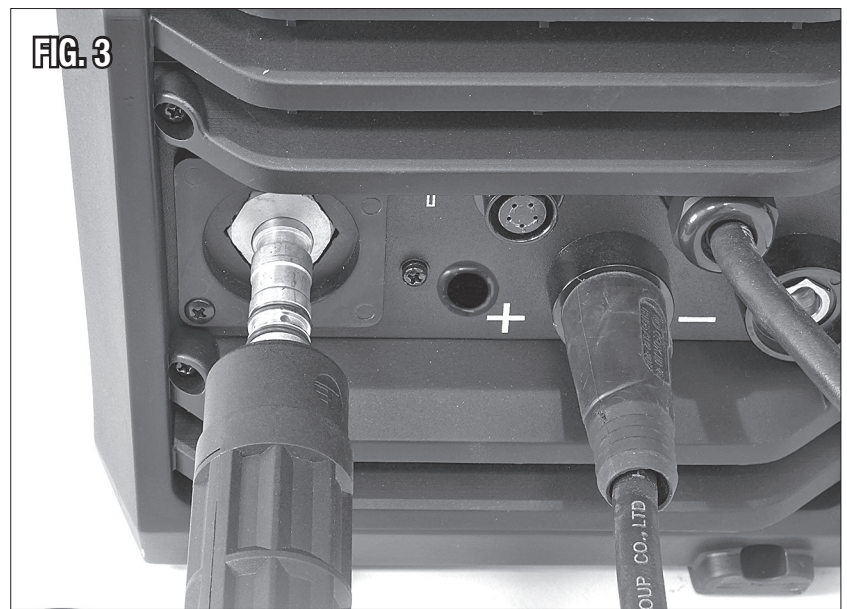
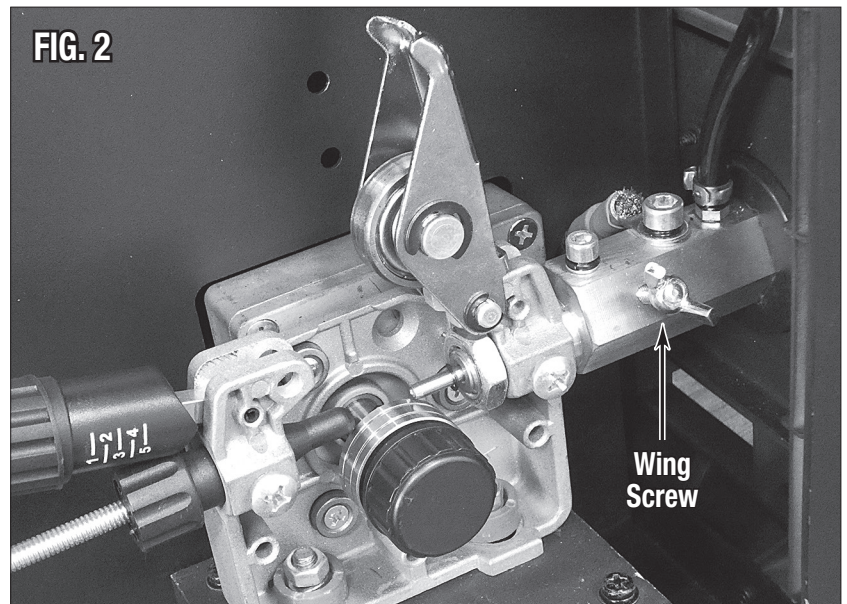



## INSTALLING THE GROUND CABLE AND CLAMP

- Locate the Ground Clamp with Cable and connect the plug on the cable end to the Ground Cable Connector (-) on the Welder. Align the key of the brass ferrule with the notch of the receptacle at the 12:00 position (FIG 6), insert the plug and twist Clockwise 1/2 turn until it is tight (FIG 7).

## CHANGING THE POLARITY FOR WELDING WITH FLUX CORE WIRE

The Eastwood MP140i comes set up to weld with Solid Wire and Shielding Gas (FIG 8). To use a Flux Cored wire, the Polarity of the short Cable Lead attached to the Front Panel must be reversed (FIG 9).

**⚠ WARNING** ELECTRIC SHOCK CAN CAUSE INJURY OR DEATH!  
Disconnect Welder from power supply before beginning.

- Disconnect the short Cable Lead from the Positive (+) Connection Receptacle by rotating the Rubber Insulator 1/2 turn Counter-Clockwise and pulling outward.
- Withdraw the Lead from the short Cable Lead from the Positive Connection Receptacle.
- Align the key of the brass ferrule with the notch of the receptacle at the 12:00 position, then insert the Lead onto the Negative (-) Connection Receptacle, seat fully and rotate 1/2 turn Clockwise to lock.
- Insert and lock the Ground Clamp Cable into the (+) Receptacle.

## INSTALLING THE SHIELDING GAS SUPPLY

**⚠ WARNING** BUILDUP OF GAS CAN INJURE OR KILL!

- Shut off shielding gas supply when not in use.
- Always ventilate confined spaces or use approved air-supplied respirator.
- Always turn your face away from valve outlet when opening cylinder valve.

**⚠ WARNING** CYLINDERS CAN EXPLODE IF DAMAGED!  
Shielding gas cylinders contain gas under high pressure. If damaged, a cylinder can explode. As gas cylinders are a normal component of the welding process, use extra care to handle them carefully.

- Protect compressed gas cylinders from excessive heat, mechanical shocks, physical damage, slag, open flames, sparks and arcs. Keep away from any welding or other electrical circuits.
- Install cylinders in an upright position by securing to a specifically designed rack, cart or stationary support to prevent falling or tipping over.
- Never weld on a pressurized cylinder or explosion will occur.
- Use only correct shielding gas cylinders, regulators, hoses and fittings designed for the specific application; maintain them and all related components in good condition.
- Keep protective cap in place over valve except when cylinder is in use.
- Use proper equipment, procedures and have adequate help when moving or lifting cylinders.

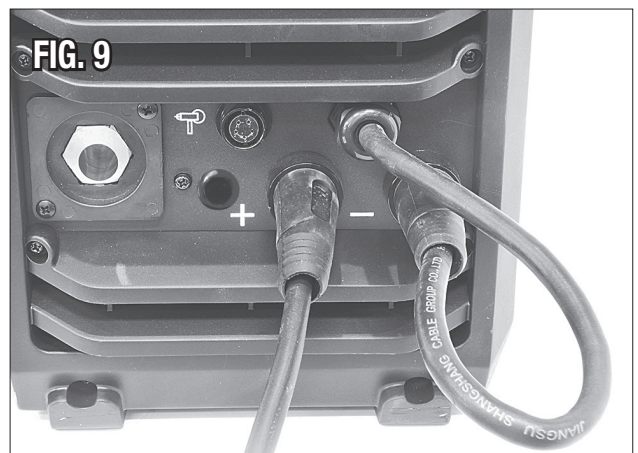
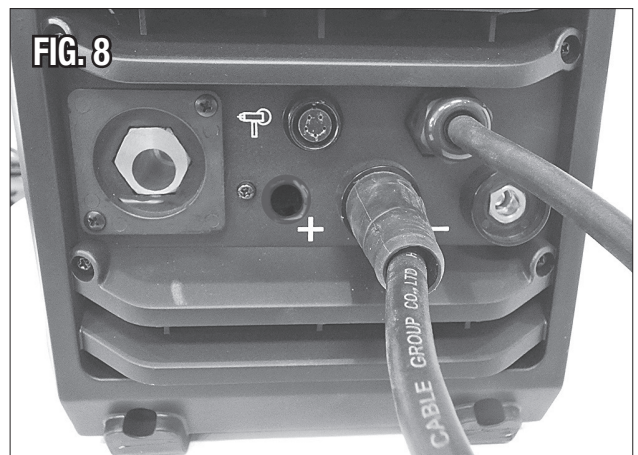
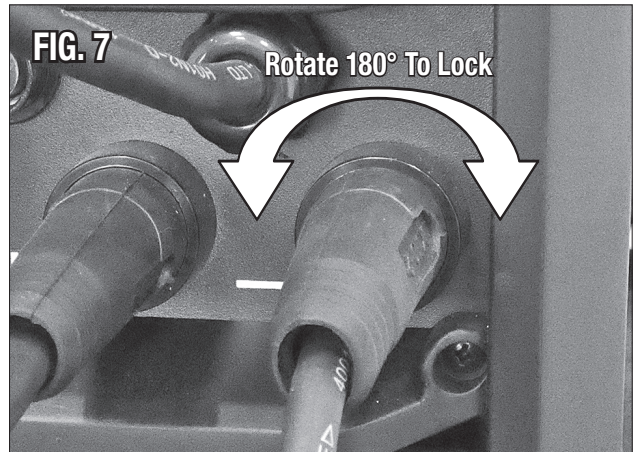
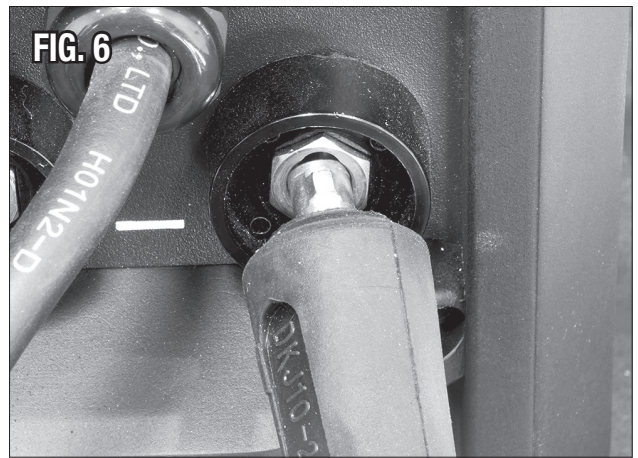



A Shielding Gas Bottle is **NOT INCLUDED** with your Eastwood MP140i but is necessary to weld using Solid Wire. It can be bought at most local Welding Supply Stores. Eastwood recommends the use of 75% Argon / 25% CO2 for shielding gas when MIG welding Steel, 100% Argon for Aluminum, and Tri-Mix (90% He / 7.5% Ar / 2.5% CO2) for Stainless Steel.

Carefully follow the following sequence to safely install and connect a Shielding Gas Bottle:

- Place the Eastwood MP140i in its dedicated area or on a welding cart.
- Secure your Shielding Gas Bottle to a stationary object or mount to your welding cart if it is equipped to hold one so that the cylinder cannot fall over.
- Remove the cap from the Shielding Gas Bottle.
- Install the Regulator Knob on the Shielding Gas Regulator (**FIG 10**).
- Insert the large brass male fitting on the Shielding Gas Regulator into the female fitting on the Shielding Gas Bottle (**FIG 11**).

**▲ NOTICE**

**Do not use White Thread Sealing Tape on this connection as it is an inert gas fitting and does not require it. If you have a leak, check for burrs or dirt in the threads.**

- Tighten the fitting with a wrench until snug, do not over tighten.
- Connect either end of the Gas Line included with your Eastwood MP140i to the fitting on the regulator and wrench tighten until snug (**FIG 11**).
- Connect the other end of the gas line to the fitting on the rear of the Eastwood MP140i and wrench tighten until snug (**FIG 12**).
- Check the gas line for leaks by slowly opening the valve on the gas bottle. When welding the valve on the bottle should always be fully open.

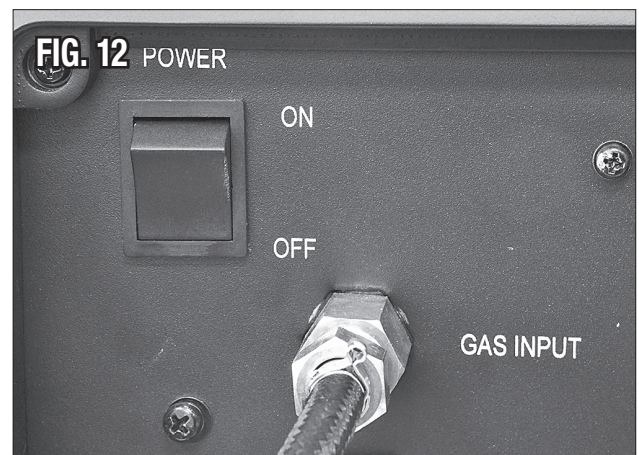
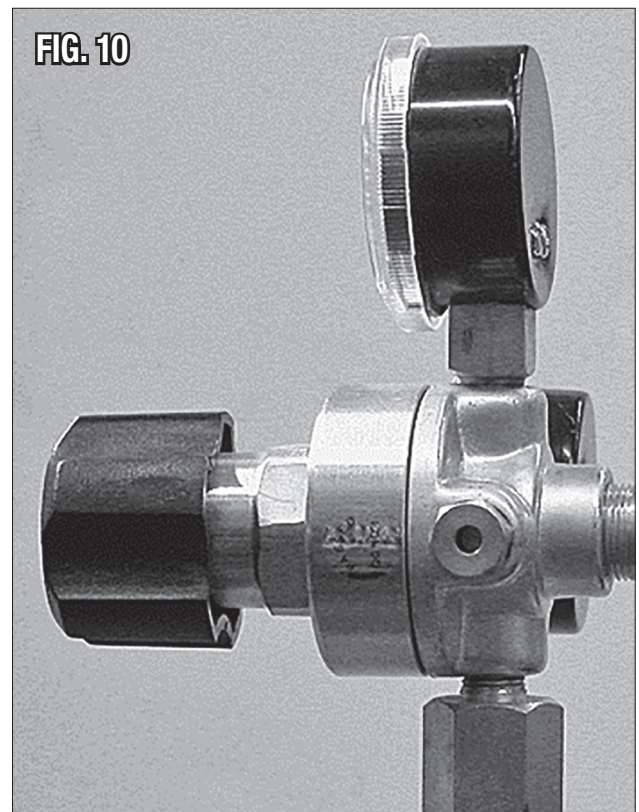



### POSITIONING THE DRIVE ROLLER

The Eastwood MP140i Wire Drive Roller has twin grooves to accommodate both 0.023" [6mm] and 0.030"/0.035" [0.8mm/0.9mm] wire.

The MP140i Drive Roller is factory set up ready to use 0.023" [0.6mm] solid wire.

**IMPORTANT NOTE:** In this position, the narrower 0.023" [0.6mm] groove is inboard, under the wire while the 0.6 marking is visible on the outward face of the Drive Roller (**FIG 13**).

0.023" [6mm] wire can be used with the Drive Roller in this position. If 0.030" [0.8mm] or 0.035" [0.9mm] wire is to be used, the drive roller position needs to be reversed.

Reverse the drive roller according to the following procedure:

- Open the side door of the Welder to access the drive motor compartment (**FIG 14**).
- Push the Pressure Adjuster rearward, pivot it down and out of the way then pivot the Tension Arm up away from the Drive Roller (**FIG 15**).
- Loosen and remove the Drive Roller Retaining Knob (**FIG 13**).
- Remove the Drive Roller and view the wire sizes stamped on each side of the Roller.
- Install the Drive Roller in the orientation so that the chosen wire size stamping is facing outward making sure shaft key aligns with the Drive Roller keyway (**FIG 13**).
- Reinstall the Drive Roller Retaining Knob on the shaft.
- Replace the Tension Arm and re-latch the Pressure Adjuster.

### INSTALLING THE WIRE SPOOL

The Eastwood MP140i can be used with either a 4" or an 8" wire spool. A 4" Spool fits directly on the Spool Shaft. To use the larger 8" spool, the included 8" Spool Adaptor is necessary.

#### To install a 4" Wire Spool:

- Open the door of the Welder and remove the Spool Retaining Knob, Spacer, and 8" Spool Adaptor from the Wire Spool Spindle.
- Slide the 4" Wire Spool onto the Spindle and reinstall the Spacer and the Spool Retaining Knob then place the 8" Spool Adaptor in a safe place if it is needed in the future.

### SETTING THE WIRE SPOOL PRESSURE ADJUSTER

- To set the tension on the wire, incrementally tighten the Spool Retaining Knob until there is a slight resistance to spinning the wire spool on the spindle. If the tension is set too loose the wire spool will freely spin on the shaft and unspool all of the wire. If the tension is too tight, the Drive Roller will have difficulty pulling the wire off the spool and some slipping may occur.

#### To install an 8" Wire Spool:

- Open the door of the Welder and remove the Spool Retaining Wingnut and Spacer from the Wire Spool Spindle.
- Slide the 8" Wire Spool Adaptor into the center of the Wire Spool.
- Slide the 8" Wire Spool Adaptor with the wire spool installed onto the spindle and reinstall the Spacer and the Spool Retaining Knob.
- Set tension on the wire as noted in above steps.

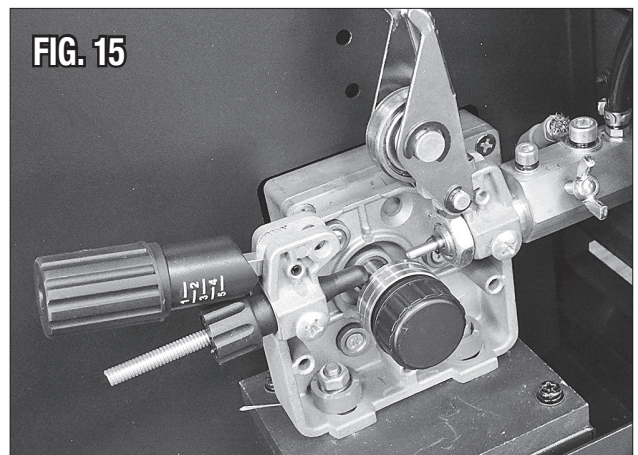
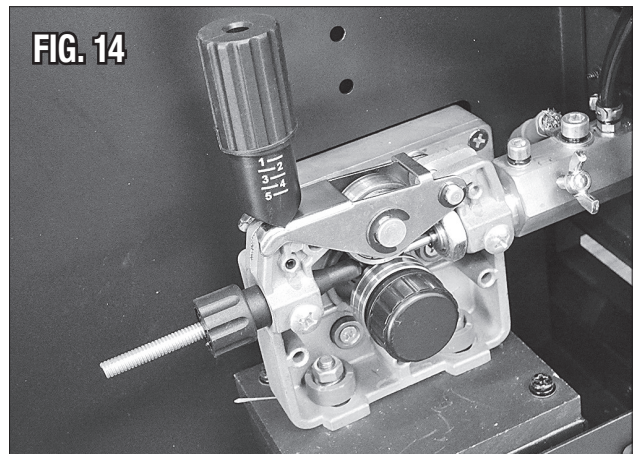
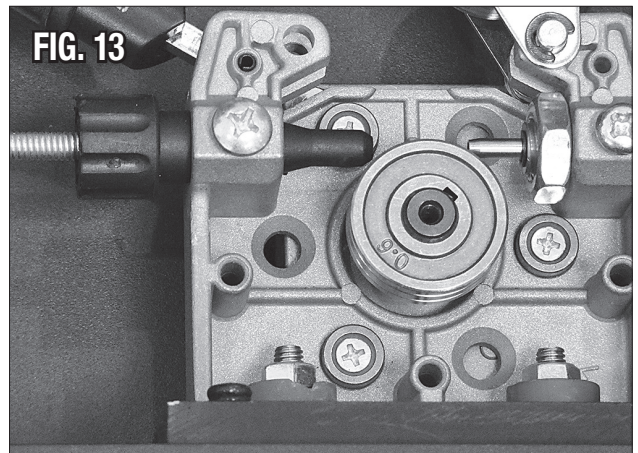

## THREADING WELDING WIRE THROUGH THE DRIVE MOTOR TO THE WELDING GUN

**⚠ WARNING** ELECTRIC SHOCK CAN CAUSE INJURY OR DEATH!  
Disconnect Welder from power supply before beginning.

This Welder uses wire sizes ranging from 0.023" to 0.035" (0.6mm to 0.9mm). To safely and correctly install the welding wire, follow the procedure in the sequence outlined below:

1. Turn the power switch on the Upper rear Panel to the "OFF" position and unplug the Welder from the power supply.
2. Set the Process Selector Switch [A] on the Front Panel to 'MIG'.
3. Remove the contact tip and nozzle from the end of the torch.
4. Ensure that the drive roller is installed in the proper "face-out position" in accordance with the wire size being used (FIG 13).
5. Push the Pressure Adjuster rearward, pivot it down and out of the way then pivot the Tension Arm up away from the Drive Roller (FIG 15).
6. Pull out the welding wire from the wire spool carefully;  
**IMPORTANT NOTE:** Do not let go of the wire or the entire spool could unravel.
7. Cut off the small piece of the curved segment at the front of welding wire and straighten the welding wire approximately 3.0" long.
8. Thread the welding wire through the Guide Pipe and over the wire Drive Roller and into the Torch Hole (FIG 16).
9. Replace the Tension Arm and re-latch the Pressure Adjuster (FIG 17).
10. Connect the Welder to a power supply and Upper rear Panel to the "ON" position. Set the Wire Speed Control [E] to about "5".
11. With the gun pointed away from you and others, depress the trigger to begin feeding wire.  
**NOTE:** The Pressure Adjuster may need to be set. To do so:
  - Watch the drive roller to see if any slipping is occurring between the roller and the wire- if so turn the machine off, unplug it and tighten the Pressure Adjuster 1/4 turn and test again.
  - Repeat the above step until wire is feeding smoothly with no binding or slippage.
12. Once the wire exits the end of the torch, reinstall the contact tip and nozzle. Cut the wire about 1/4" from the end of the contact tip.

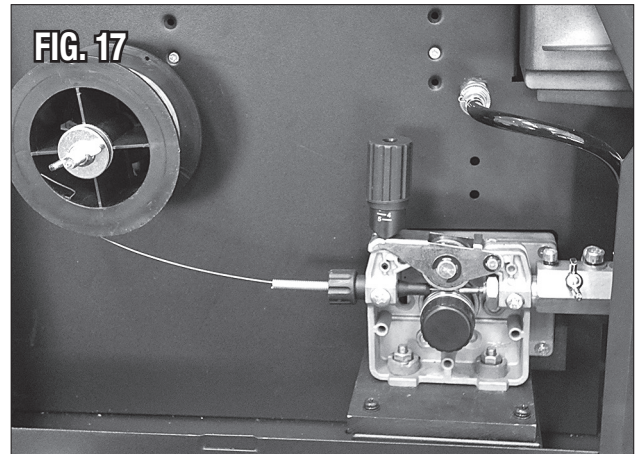
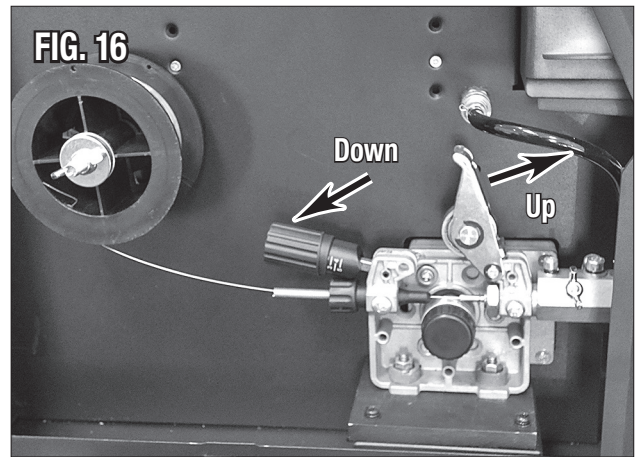

# MIG WELDING OPERATION

## **⚠ DANGER** ELECTRIC SHOCK CAN CAUSE INJURY OR DEATH!

- Improper use of an electric Welder can cause electric shock, injury and death! Read all precautions described in the Welder Manual to reduce the possibility of electric shock.
- Disconnect Welder from power supply before assembly, disassembly or maintenance of the torch, contact tip and when installing or removing nozzles.
- Always wear dry, protective clothing and leather welding gloves and insulated footwear. Use suitable clothing made from durable flame-resistant material to protect your skin.
- Always operate the Welder in a clean, dry, well ventilated area. Do not operate the Welder in humid, wet, rainy or poorly ventilated areas.
- The electrode and work (or ground) circuits are electrically “hot” when the Welder is on. Do not allow these “hot” parts to come in contact with your bare skin or wet clothing.
- Separate yourself from the welding circuit by using insulating mats to prevent contact from the work surface.
- Be sure that the work piece is properly supported and grounded prior to beginning an electric welding operation.
- Always attach the ground clamp to the piece to be welded and as close to the weld area as possible. This will give the least resistance and best weld.

## **⚠ DANGER** WELDING SPARKS CAN CAUSE FIRE OR EXPLOSION!

- Electric welding produces sparks which can be discharged considerable distances at high velocity igniting flammable or exploding vapors and materials.
- Do not operate electric arc Welder in areas where flammable or explosive vapors are present.
- Do not use near combustible surfaces. Remove all flammable items within 35 feet of the welding area.
- Always keep a fire extinguisher nearby while welding.
- Use welding blankets to protect painted and or flammable surfaces; rubber weather-stripping, dash boards, engines, etc.
- If other persons or pets are in the area of welding, use welding screens to protect bystanders from sparks.

## **⚠ DANGER** ELECTROMAGNETIC FIELDS CAN BE A HEALTH HAZARD!

- The electromagnetic field that is generated during arc welding may interfere with various electrical and electronic devices such as cardiac pacemakers. Anyone using such devices should consult with their physician prior to performing any electric welding operations.
- Exposure to electromagnetic fields while welding may have other health effects which are not known.

## **⚠ WARNING** ARC RAYS CAN BURN!

- Arc rays produce intense ultraviolet radiation which can burn exposed skin and cause eye damage. Use a shield with the proper filter (a minimum of #11) to protect your eyes from sparks and the rays of the arc when welding or when observing open arc welding (see ANSI Z49.1 and Z87.1 for safety standards).
- Use suitable clothing made from durable flame-resistant material to protect your skin.
- If other persons or pets are in the area of welding, use welding screens to protect bystanders from sparks and arc rays.

## **⚠ WARNING** FUMES AND WELDING GASES CAN BE A HEALTH HAZARD!

- Fumes and gasses released during welding are hazardous. Do not breathe fumes that are produced by the welding operation. Wear an OSHA-approved respirator when welding.
- Always work in a properly ventilated area.
- Never weld coated materials including but not limited to: cadmium plated, galvanized, lead based paints.



**⚠ CAUTION HOT METAL AND TOOLS WILL BURN!**

- Electric welding heats metal and tools to temperatures that will cause severe burns!
- Use protective, heat resistant gloves and clothing when using Eastwood or any other welding equipment. Never touch welded work surface, torch tip or nozzle until they have completely cooled.

**⚠ CAUTION FLYING METAL CHIPS CAN CAUSE INJURY!**

- Grinding and sanding will eject metal chips, dust, debris and sparks at high velocity. To prevent eye injury wear approved safety glasses.
- Wear an OSHA-approved respirator when grinding or sanding.
- Read all manuals included with specific grinders, sanders or other power tools used before and after the welding process. Be aware of all power tool safety warnings.

**⚠ CAUTION INADEQUATE WIRING CAN CAUSE FIRE AND INJURY!**

- Verify that the facility power source has properly rated wiring to handle power requirements of this Welder.

Your Eastwood MP140i can be used to form many different joints and welds all of which will require practice and testing before using on an actual project piece. This following welding process is just a baseline to get you started.

- Refer to the 'Suggested Settings' chart which is located inside the side door of your Eastwood Welder. From the chart select your baseline starting point for the recommended settings described in the chart.
- Connect your ground clamp to the work pieces that are to be welded. Make sure the ground clamp contacts are placed on a clean piece of metal free of paint, grease, rust, oils, etc. It is recommended to place your ground clamp as close to the weld area as possible.
- Assess your weld area and make sure the welding area is also cleaned of any paint, grease, rust, oils, etc.
- Plug in the Welder and move the Power Switch at the Upper Rear Panel to the "ON" position Depress the Welding Gun trigger pointing the welding gun away from your body and then let go of the trigger and cut the wire back to ~1/4" stick out length.
- Wearing your welding helmet, gloves, and long sleeve shirt and pants, put the end of the wire sticking out of the gun into the joint to be welded.
- Position the MIG Gun so that it is perpendicular to the base metal with ~20° tilt back.
- Depress the trigger to start the wire feed which starts the arc.

**NOTE:** A push, perpendicular, or drag technique can be used to weld the pieces together; the type used depends on the type of joint as well as other influential conditions.

- Once you depress the trigger and the arc has started, you will notice a molten puddle will form; this puddle is the weld bead and will follow the motion of the MIG Gun. Watching the size of the puddle dictates how fast you should be moving with the torch. If you burn through the material you are either moving too slow or you need to make some setting adjustments to the Welder settings. If you're not penetrating the base metal you're either moving too fast or you need to make adjustments to the Welder settings.
- Release the trigger on the MIG Gun to stop the weld.
- After welding is complete, turn off the Welder and disconnect from power source.

## **SHEET METAL WELDING TECHNIQUES**

When welding sheet metal a different approach is usually taken to account for how thin the metal is and it's susceptible to warping it is. The technique most often used is called Stitch Welding and this process is described below:

- Clean the metal to be welded of any paint, rust, oil, grease, dirt or any other contaminants that may be on the surface of the piece.
- Secure the pieces to be welded in place using clamps. Be sure to leave a small gap between the two pieces of sheet metal for the weld to flow into, this will result in a lower bead height which will require minimal finishing.
- Consult the Suggested Settings Chart and set the Voltage and Wire Speed knobs appropriately.
- Get some pieces of scrap metal of the same thickness and verify that the settings will work for the specific weld you will be making.
- Once the settings have been fine-tuned tack weld your final pieces in places and remove the clamps if they are in the way of the weld.
- The Stitch Welding technique can now be utilized which is basically a series of tacks connecting together. To perform the technique, trigger the gun to form a tack weld and then continue to trigger on and off the gun making a series of connected tack welds following along the path of the weld joint. Continue the series of tacks for an inch or so and then move to a different section of the weld and perform the process there. It is essential to keep moving around to spread out the heat making sure not to get one section too hot and warp the metal.
- Once the entire weld has been completed allow the metal to cool. If necessary follow up with a flap disc to grind the weld bead flush.

## **HEAVY GAUGE METAL WELDING TECHNIQUES**

When welding heavy gauge metal, a continuous bead is formed using a 'push' method. This process is described below:

- Clean the metal to be welded of any paint, rust, oil, grease, dirt or any other contaminants that may be on the surface of the piece.
- Secure the pieces to be welded in place using clamps. Be sure to leave a small gap between the two pieces of metal for the weld to flow into, this will result in a lower bead height which will require minimal finishing. Any material thicker than 1/8" should be beveled using an angle grinder.
- Consult the Suggested Settings Chart and set the Voltage and Wire Speed knobs appropriately.
- Get some pieces of scrap metal of the same thickness and verify that the settings will work for the specific weld you will be making.
- Once the settings have been fine-tuned tack weld your final pieces in places and remove the clamps if they are in the way of the weld.
- When welding heavy gauge metal there are two basic approaches to creating the weld. The first is a continuous bead with steady gun movement along the length of the joint. The second type of weld is a Stringer or Weave bead. This is accomplished by moving the torch in a circular or zig zag pattern. Either of these techniques will create strong welds but in some cases the Stringer or Weave type will create a more aesthetically pleasing weld bead.
- Once the entire weld has been completed, allow the metal to cool. If necessary, follow up with a flap disc to grind the weld bead flush.

# STICK WELDING SET-UP AND OPERATION

## **⚠ DANGER** ELECTRIC SHOCK CAN CAUSE INJURY OR DEATH!

- Improper use of an electric Welder can cause electric shock, injury and death! Read all precautions described in the Welder Manual to reduce the possibility of electric shock.
- Disconnect Welder from power supply before assembly, disassembly or maintenance of the torch, contact tip and when installing or removing nozzles.
- Always wear dry, protective clothing and leather welding gloves and insulated footwear. Use suitable clothing made from durable flame-resistant material to protect your skin.
- Always operate the Welder in a clean, dry, well ventilated area. Do not operate the Welder in humid, wet, rainy or poorly ventilated areas.
- The electrode and work (or ground) circuits are electrically “hot” when the Welder is on. Do not allow these “hot” parts to come in contact with your bare skin or wet clothing.
- Separate yourself from the welding circuit by using insulating mats to prevent contact from the work surface.
- Be sure that the work piece is properly supported and grounded prior to beginning an electric welding operation.
- Always attach the ground clamp to the piece to be welded and as close to the weld area as possible. This will give the least resistance and best weld.

## **⚠ DANGER** WELDING SPARKS CAN CAUSE FIRE OR EXPLOSION!

- Electric welding produces sparks which can be discharged considerable distances at high velocity igniting flammable or exploding vapors and materials.
- Do not operate electric arc Welder in areas where flammable or explosive vapors are present.
- Do not use near combustible surfaces. Remove all flammable items within 35 feet of the welding area.
- Always keep a fire extinguisher nearby while welding.
- Use welding blankets to protect painted and or flammable surfaces; rubber weather-stripping, dash boards, engines, etc.
- If other persons or pets are in the area of welding, use welding screens to protect bystanders from sparks.

## **⚠ DANGER** ELECTROMAGNETIC FIELDS CAN BE A HEALTH HAZARD!

- The electromagnetic field that is generated during arc welding may interfere with various electrical and electronic devices such as cardiac pacemakers. Anyone using such devices should consult with their physician prior to performing any electric welding operations.
- Exposure to electromagnetic fields while welding may have other health effects which are not known.

## **⚠ WARNING** ARC RAYS CAN BURN!

- Arc rays produce intense ultraviolet radiation which can burn exposed skin and cause eye damage. Use a shield with the proper filter (a minimum of #11) to protect your eyes from sparks and the rays of the arc when welding or when observing open arc welding (see ANSI Z49.1 and Z87.1 for safety standards).
- Use suitable clothing made from durable flame-resistant material to protect your skin.
- If other persons or pets are in the area of welding, use welding screens to protect bystanders from sparks and arc rays.

## **⚠ WARNING** FUMES AND WELDING GASES CAN BE A HEALTH HAZARD!

- Fumes and gasses released during welding are hazardous. Do not breathe fumes that are produced by the welding operation. Wear an OSHA-approved respirator when welding.
- Always work in a properly ventilated area.
- Never weld coated materials including but not limited to: cadmium plated, galvanized, lead based paints.



**⚠ CAUTION HOT METAL AND TOOLS WILL BURN!**

- Electric welding heats metal and tools to temperatures that will cause severe burns!
- Use protective, heat resistant gloves and clothing when using Eastwood or any other welding equipment. Never touch welded work surface, torch tip or nozzle until they have completely cooled.

**⚠ CAUTION FLYING METAL CHIPS CAN CAUSE INJURY!**

- Grinding and sanding will eject metal chips, dust, debris and sparks at high velocity. To prevent eye injury wear approved safety glasses.
- Wear an OSHA-approved respirator when grinding or sanding.
- Read all manuals included with specific grinders, sanders or other power tools used before and after the welding process. Be aware of all power tool safety warnings.

**⚠ CAUTION INADEQUATE WIRING CAN CAUSE FIRE AND INJURY!**

- Verify that the facility power source has properly rated wiring to handle power requirements of this Welder.

**STICK WELD SET-UP****⚠ DANGER ELECTRIC SHOCK CAN CAUSE INJURY OR DEATH!**

- Disconnect Welder from power supply before beginning.

Set the Welder on a flat surface in the general area where the Welder will be used. A dedicated cart is best.

- Set the Process Selector Switch **[A]** on the Front Panel to 'Stick/TIG'.
- Locate the Ground Clamp with Cable and connect the plug on the cable end into the Negative (-) receptacle on the Lower Right Front Panel of the Welder. To connect the plug; align the key of the brass ferrule with the notch of the receptacle at the 12:00 position then rotate 1/2 turn Clockwise to lock.
- Locate the Electrode Holder with Cable and connect the plug on the cable end into the Positive (+) Connection Receptacle on the Lower Front Panel of the Welder. To connect the plug; align the key of the brass ferrule with the notch of the receptacle at the 12:00 position then rotate 1/2 turn Clockwise to lock.
- Connect the Welder to a power source. This Welder requires a minimum 20 Amp, 120 VAC, 50/60 Hz Protected Circuit.
- Insert the electrode to be used into the Electrode Holder.
- Connect the Ground Clamp to a clean bare metal surface of the part to be welded.
- Turn on the Power Switch at the Rear Panel of the Welder.
- The Welder is now ready to use.

**STICK WELDING OPERATION****Electrode Selection**

Before beginning welding with your Eastwood MP140i, you will need to purchase electrodes as these are a consumable item in the ARC welding process. There are a variety of different types of rods available and should be selected depending on the project on hand. The chart below is an overview of some of the most popular electrodes.

Electrode	Polarity	Usage
E6010	DCEP	This electrode works well for welding rusty, dirty, painted, or greasy steels.
E6011	DCEP	This electrode is a general purpose rod used for carbon and galvanized steel. It is recommended for use when deep penetration is necessary.
E6013	DCEP, DCEN	This electrode is a general purpose rod used for welding carbon steel with poor-fitting joints. It is capable of light penetration.
E7014	DCEP, DCEN	This electrode can be used where a high deposition is necessary along with fast travel speed. It is capable of light penetration.
E7018	DCEP	This electrode is best for use with clean, bare steel and is suitable for moderate penetration.

## **POLARITY SELECTION**

The Eastwood MP140i can weld in both Direct Current Electrode Positive (DCEP) and Direct Current Electrode Negative (DCEN). The electrode, or rod, when welding in DCEP is positive and the grounded surface is negative. This polarity is used with electrodes that specify it and is usually the most commonly used polarity when ARC welding for general purpose use. The electrode when welding in DCEN is negative and the grounded surface is positive. This polarity is used with electrodes that require using this polarity and is usually used for building up heavy deposits of material with less penetration.

### **To use the Eastwood MP140i in DCEP:**

- Locate the Ground Clamp with Cable and connect the plug on the cable end to the Ground Cable Connector (–) on the Welder. To connect the plug line up the key on the plug with the keyway on the socket of the Welder, insert the plug and twist until it is tight.
- Locate the Electrode Holder with Cable and connect the plug on the cable end to the Electrode Holder Connector (+) on the Welder. To connect the plug line up the key on the plug with the keyway of the socket on the Welder, insert the plug and twist until it is tight.

### **To use the Eastwood MP140i in DCEN:**

- Locate the Ground Clamp with Cable and connect the plug on the cable end to the Positive Connector (+) on the Welder. To connect the plug line up the key on the plug with the keyway on the socket of the Welder, insert the plug and twist until it is tight.
- Locate the Electrode Holder with Cable and connect the plug on the cable end to the Negative Connector (–) on the Welder. To connect the plug line up the key on the plug with the keyway on the socket of the Welder, insert the plug and twist until it is tight.

### **⚠ DANGER ELECTRIC SHOCK CAN CAUSE INJURY OR DEATH!**

- **Improper use of an electric Welder can cause electric shock, injury and death! Read all precautions described in the Welder Manual to reduce the possibility of electric shock.**
- **Disconnect Welder from power supply before assembly, disassembly or maintenance of the torch, contact tip and when installing or removing nozzles.**
- **Always wear dry, protective clothing and leather welding gloves and insulated footwear. Use suitable clothing made from durable flame-resistant material to protect your skin.**
- **Always operate the Welder in a clean, dry, well ventilated area. Do not operate the Welder in humid, wet, rainy or poorly ventilated areas.**
- **The electrode and work (or ground) circuits are electrically “hot” when the Welder is on. Do not allow these “hot” parts to come in contact with your bare skin or wet clothing.**
- **Separate yourself from the welding circuit by using insulating mats to prevent contact from the work surface.**
- **Be sure that the work piece is properly supported and grounded prior to beginning an electric welding operation.**
- **Always attach the ground clamp to the piece to be welded and as close to the weld area as possible. This will give the least resistance and best weld.**

### **⚠ DANGER WELDING SPARKS CAN CAUSE FIRE OR EXPLOSION!**

- **Electric welding produces sparks which can be discharged considerable distances at high velocity igniting flammable or exploding vapors and materials.**
- **Do not operate electric arc Welder in areas where flammable or explosive vapors are present.**
- **Do not use near combustible surfaces. Remove all flammable items within 35 feet of the welding area.**
- **Always keep a fire extinguisher nearby while welding.**
- **Use welding blankets to protect painted and or flammable surfaces; rubber weather-stripping, dash boards, engines, etc.**
- **If other persons or pets are in the area of welding, use welding screens to protect bystanders from sparks.**

### **⚠ DANGER ELECTROMAGNETIC FIELDS CAN BE A HEALTH HAZARD!**

- **The electromagnetic field that is generated during arc welding may interfere with various electrical and electronic devices such as cardiac pacemakers. Anyone using such devices should consult with their physician prior to performing any electric welding operations.**
- **Exposure to electromagnetic fields while welding may have other health effects which are not known.**

**⚠ WARNING ARC RAYS CAN BURN!**

- Arc rays produce intense ultraviolet radiation which can burn exposed skin and cause eye damage. Use a shield with the proper filter (a minimum of #11) to protect your eyes from sparks and the rays of the arc when welding or when observing open arc welding (see ANSI Z49.1 and Z87.1 for safety standards).
- Use suitable clothing made from durable flame-resistant material to protect your skin.
- If other persons or pets are in the area of welding, use welding screens to protect bystanders from sparks and arc rays.

**⚠ WARNING FUMES AND WELDING GASES CAN BE A HEALTH HAZARD!**

- Fumes and gasses released during welding are hazardous. Do not breathe fumes that are produced by the welding operation. Wear an OSHA-approved respirator when welding.
- Always work in a properly ventilated area.
- Never weld coated materials including but not limited to: cadmium plated, galvanized, lead based paints.

**⚠ CAUTION HOT METAL AND TOOLS WILL BURN!**

- Electric welding heats metal and tools to temperatures that will cause severe burns!
- Use protective, heat resistant gloves and clothing when using Eastwood or any other welding equipment. Never touch welded work surface, torch tip or nozzle until they have completely cooled.

**⚠ CAUTION FLYING METAL CHIPS CAN CAUSE INJURY!**

- Grinding and sanding will eject metal chips, dust, debris and sparks at high velocity. To prevent eye injury wear approved safety glasses.
- Wear an OSHA-approved respirator when grinding or sanding.
- Read all manuals included with specific grinders, sanders or other power tools used before and after the welding process. Be aware of all power tool safety warnings.

**⚠ CAUTION INADEQUATE WIRING CAN CAUSE FIRE AND INJURY!**

- Verify that the facility power source has properly rated wiring to handle power requirements of this Welder.

**STICK WELDING PROCEDURE**

- Set up a clean well lit work area.
- Prepare the parts to be welded by cleaning the weld joint area of any rust, dirt, grease, or paint.
- Select the proper electrode for the weld joint.
- Turn on the Welder and select the appropriate amperage. To determine proper amperage it is best to practice on some similar metals to set up the machine before welding on an actual part of value.
- Attach the ground clamp to a clean bare metal section on the work piece.
- Insert the electrode into the electrode holder being careful not to allow the electrode to contact the grounded area.
- To start welding an arc must be struck, to do this a motion similar to striking a match will have to be performed with the electrode. Slowly bring the electrode closer to the weld joint and then contact and drag the electrode across the piece to strike the arc. Once the arc has been struck you can continue feeding the electrode into the weld joint.
- While moving along the weld joint the electrode will burn down, while it is burning you will need to continue moving the electrode closer to the joint trying to keep a 1/8" gap between the end of the electrode and the weld joint. The electrode holder must be held so that the electrode is in a downward angle moving in the direction of the weld joint.
- To stop welding simply lift the electrode away from the work piece. When finished welding remove the electrode from the holder and turn off the Welder.

# TIG WELDING SET-UP AND OPERATION

## SHIELDING GAS CONNECTION FOR TIG TORCH

### **⚠ WARNING** BUILDUP OF GAS CAN INJURE OR KILL!

- Shut off shielding gas supply when not in use.
- Always ventilate confined spaces or use approved air-supplied respirator.
- Always turn your face away from valve outlet when opening cylinder valve.

### **⚠ WARNING** CYLINDERS CAN EXPLODE IF DAMAGED!

- Shielding gas cylinders contain gas under high pressure. If damaged, a cylinder can explode. As gas cylinders are a normal component of the welding process, use extra care to handle them carefully.
- Protect compressed gas cylinders from excessive heat, mechanical shocks, physical damage, slag, open flames, sparks and arcs. Keep away from any welding or other electrical circuits.
- Install cylinders in an upright position by securing to a specifically designed rack, cart or stationary support to prevent falling or tipping over.
- Never weld on a pressurized cylinder or explosion will occur.
- Use only correct shielding gas cylinders, regulators, hoses and fittings designed for the specific application; maintain them and all related components in good condition.
- Keep protective cap in place over valve except when cylinder is in use.
- Use proper equipment, procedures and have adequate help when moving or lifting cylinders.

A Shielding Gas Bottle is **NOT INCLUDED** with your Eastwood MP140i TIG Torch Kit but is necessary for TIG welding. A Shielding Gas Bottle can be bought at most local Welding Supply Stores. Eastwood recommends the use of 100% Argon shielding gas when TIG welding Steel and Stainless Steel.

After connecting your Shielding Gas Regulator, the gas flow rate needs to be adjusted so that the proper amount of Shielding Gas is flowing over your weld. If there is too little gas flow there will be porosity in your welds as well as excessive spatter, if there is too much gas flow you will be wasting gas and may affect the weld quality.

- Place the Eastwood MP140i in its dedicated area or on a welding cart.
- Secure your Shielding Gas Bottle to a stationary object or mount to your welding cart if it is equipped to hold one so that the cylinder cannot fall over.
- Remove the cap from the Shielding Gas Bottle.
- Install the Regulator Knob on the Shielding Gas Regulator (**FIG 10**).
- Insert the large brass male fitting on the Shielding Gas Regulator into the female fitting on the Shielding Gas Bottle (**FIG 11**).

### **⚠ NOTICE**

- Do not use White Thread Sealing Tape on this connection as it is an inert gas fitting and does not require it, if you have a leak check for burrs or dirt in the threads.

- Tighten the fitting with a wrench until snug, do not over tighten.
- Connect Tig Torch gas line to the fitting on the Regulator and wrench-tighten until snug (**FIG 11**).
- Check the gas line for leaks by slowly opening the valve on the gas bottle. When welding, the valve on the bottle should always be fully open.



## TORCH ASSEMBLY/DISASSEMBLY

### Disassembly:

- Make sure the welder is turned OFF and unplugged.
- Remove the Back Cap from the Torch.
- If there is a Tungsten installed in the Torch pull it out of the front of the Torch.
- Slide the Collet out of the Torch.
- Unscrew and remove the Gas Shielding Nozzle.
- Unscrew and remove the Collet body.

### Assembly: (Fig 18)

- Select a Collet body that matches your Tungsten diameter size and thread it into the front of the Torch.
- Select a Collet that matches your Tungsten diameter size. Insert the Tungsten into the Collet and put the Collet and Tungsten back into the Torch.
- The Gas Shielding Nozzle size should be changed according to shielding gas requirements for the material being welded. Thicker material requires a larger Nozzle. Select the correct Gas Shielding Nozzle and thread it onto the Collet body.
- Install the back cap to lock the Tungsten in place. Always make sure the Tungsten protrudes 1/8" to 1/4" beyond the Gas Shielding Nozzle (FIG 19).
- Unscrew and remove the Collet body.

## SHARPENING THE TUNGSTEN

To avoid contamination of the Tungsten and ultimately the weld, it is imperative to have a dedicated grinding wheel used for Tungsten grinding only. A fine grit standard 6" synthetic stone grinding wheel on a bench top grinder is sufficient or specifically designed Tungsten Grinders are available.

- Shut off the welder.
- Make sure the Tungsten and Torch are sufficiently cooled for handling then loosen and remove the Back Cap then the Collet and remove the Tungsten from the FRONT of the Torch only. (Removing from the rear will damage the Collet).
- If the Tungsten is used and the end is contaminated, use pliers or a suitable tool to grip the Tungsten above the contaminated section and snap off the end of the Tungsten.
- Holding the Tungsten tangent to the surface of the grinding wheel, rotate the Tungsten while exerting light pressure until a suitable point is formed. The ideal tip will have the length of the conical portion of the sharpened area at 2-1/2 times the Tungsten rod diameter (FIG 20).
- Replace the Tungsten in the Collet with the tip extending 1/8"-1/4" beyond the Gas Shielding Nozzle, then re-tighten the Back Cap (FIG 21).

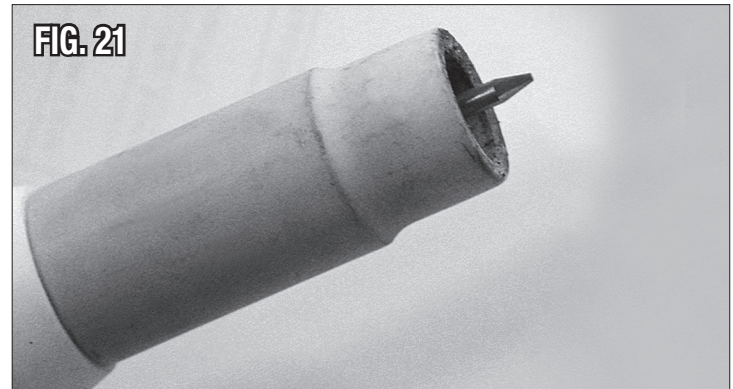
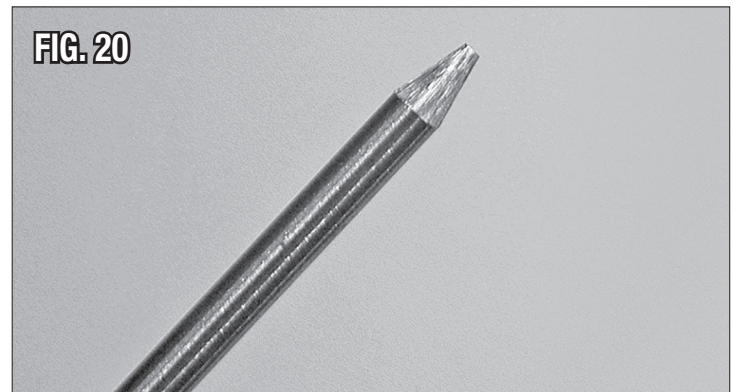
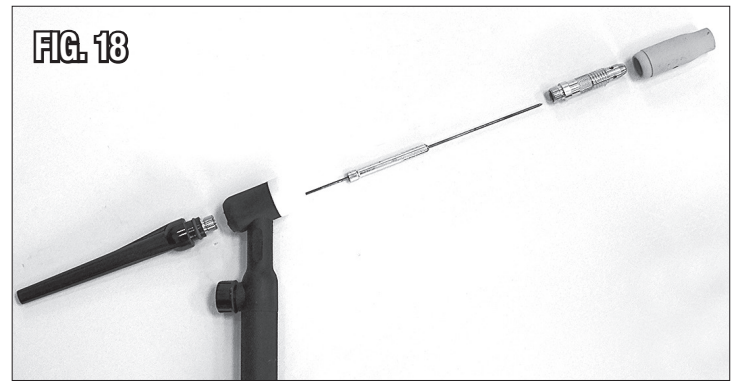

## TIG WELDING SET-UP

### **⚠ DANGER** ELECTRIC SHOCK CAN CAUSE INJURY OR DEATH!

- **Disconnect Welder from power supply before beginning.**

- Set the Welder on a flat surface in the general area where the Welder will be used. A dedicated cart is best.
- Set the Process Selector Switch **[A]** on the Front Panel to “Stick/TIG”.
- Insert the Brass Connector of the TIG Torch Cable into the Negative (–) on the Lower Left Front Panel of the Welder. To connect the plug line up the key on the plug with the keyway on the socket of the Welder, insert the plug and twist until it is tight.
- Insert the Brass Connector of the Ground Cable into the Positive (+) on the Lower Right Front Panel of the Welder. To connect the plug line up the key on the plug with the keyway on the socket of the Welder, insert the plug and twist ½ turn until it is tight.
- Connect the Welder to a power source. This Welder requires a minimum 20 Amp, 120 VAC, 50/60 Hz Protected Circuit.
- Insert the electrode to be used into the Electrode Holder.
- Connect the Ground Clamp to a clean bare metal surface of the part to be welded.
- Turn on the Power Switch at the Upper Rear Panel of the Welder.
- The Welder is now ready for use.

## TIG WELDING

### **⚠ DANGER** ELECTRIC SHOCK CAN CAUSE INJURY OR DEATH!

- **Improper use of an electric Welder can cause electric shock, injury and death! Read all precautions described in the Welder Manual to reduce the possibility of electric shock.**
- **Disconnect Welder from power supply before assembly, disassembly or maintenance of the torch, contact tip and when installing or removing nozzles.**
- **Always wear dry, protective clothing and leather welding gloves and insulated footwear. Use suitable clothing made from durable flame-resistant material to protect your skin.**
- **Always operate the Welder in a clean, dry, well ventilated area. Do not operate the Welder in humid, wet, rainy or poorly ventilated areas.**
- **The electrode and work (or ground) circuits are electrically “hot” when the Welder is on. Do not allow these “hot” parts to come in contact with your bare skin or wet clothing.**
- **Separate yourself from the welding circuit by using insulating mats to prevent contact from the work surface.**
- **Be sure that the work piece is properly supported and grounded prior to beginning an electric welding operation.**
- **Always attach the ground clamp to the piece to be welded and as close to the weld area as possible. This will give the least resistance and best weld.**

### **⚠ DANGER** WELDING SPARKS CAN CAUSE FIRE OR EXPLOSION!

- **Electric welding produces sparks which can be discharged considerable distances at high velocity igniting flammable or exploding vapors and materials.**
- **Do not operate electric arc Welder in areas where flammable or explosive vapors are present.**
- **Do not use near combustible surfaces. Remove all flammable items within 35 feet of the welding area.**
- **Always keep a fire extinguisher nearby while welding.**
- **Use welding blankets to protect painted and or flammable surfaces; rubber weather-stripping, dash boards, engines, etc.**
- **If other persons or pets are in the area of welding, use welding screens to protect bystanders from sparks.**

**⚠ DANGER ELECTROMAGNETIC FIELDS CAN BE A HEALTH HAZARD!**

- The electromagnetic field that is generated during arc welding may interfere with various electrical and electronic devices such as cardiac pacemakers. Anyone using such devices should consult with their physician prior to performing any electric welding operations.
- Exposure to electromagnetic fields while welding may have other health effects which are not known.

**⚠ WARNING ARC RAYS CAN BURN!**

- Arc rays produce intense ultraviolet radiation which can burn exposed skin and cause eye damage. Use a shield with the proper filter (a minimum of #11) to protect your eyes from sparks and the rays of the arc when welding or when observing open arc welding (see ANSI Z49.1 and Z87.1 for safety standards).
- Use suitable clothing made from durable flame-resistant material to protect your skin.
- If other persons or pets are in the area of welding, use welding screens to protect bystanders from sparks and arc rays.

**⚠ WARNING FUMES AND WELDING GASES CAN BE A HEALTH HAZARD!**

- Fumes and gasses released during welding are hazardous. Do not breathe fumes that are produced by the welding operation. Wear an OSHA-approved respirator when welding.
- Always work in a properly ventilated area.
- Never weld coated materials including but not limited to: cadmium plated, galvanized, lead based paints.

**⚠ CAUTION HOT METAL AND TOOLS WILL BURN!**

- Electric welding heats metal and tools to temperatures that will cause severe burns!
- Use protective, heat resistant gloves and clothing when using Eastwood or any other welding equipment. Never touch welded work surface, torch tip or nozzle until they have completely cooled.

**IMPORTANT NOTE:** These instructions are intended only to provide the user with some familiarity of the Eastwood MP140i. TIG welding is a highly complex procedure with many variables. If you have no experience with TIG welding; it is extremely important to seek the advice of someone experienced in TIG welding for instruction, enroll in a local technical school welding course or study a comprehensive how-to DVD and obtain a good quality reference book on TIG welding as there is a moderate learning curve necessary before achieving proficiency in TIG Welding. Before attempting to use this unit on an actual project or object of value, practice on a similar material as there are many variables present and settings required when TIG welding different metals such as steel and stainless steel. It is also strongly recommended that the user adhere to the American Welding Society guidelines, codes and applications prior to producing welds where safety is affected.

- Turn the Power Switch at the Upper Rear Panel to the "ON" position.
- Slowly open the gas cylinder valve. **NOTE:** Always open valve fully to avoid shielding gas leakage.
- Adjust the flow regulator built-in to the Torch Handle. Rotate Counter-clockwise to open, Clockwise to Close.
- Grounding is very important, place the Ground Cable Clamp on a clean, bare area of your work piece as close to the welding area as possible to minimize the chance of shock. Scrape, wire brush, file or grind a bare area to achieve a good ground to assure safety.
- Use a dedicated stainless steel brush or flap-disc to clean the areas to be welded. Do not use the brush or flap-disc for any other purpose.
- Making sure all your safety gear is in place (Welding Mask, Welding Gloves, non-flammable long sleeve apparel) and the area is completely free of flammable material.
- Although it is a matter of developing a personal style, a good starting point for best results is achieved by holding the tip at a 45° angle backward and approx. 20° to the right of the weld. Hold the Filler Metal Rod at a 60° angle to the Tungsten Tip. Never allow the Tungsten Tip to touch the welding surface or material rod. Doing so will quickly destroy the tip and contaminate the weld. If this happens, remove the Tungsten and regrind the tip. It is best to hold the Tungsten tip 1/8" from the surface.
- With your Welding Shield and all safety gear in place, practice "Forming a Puddle" with the Tungsten Tip. Once you become familiar with this step. Practice the "Dip and Pull" technique with the Filler Metal Rod and Torch. "Dip and Pull" is the practice of forming a puddle, moving the Torch while maintaining the puddle and adding filler rod metal to the puddle by "dipping and pulling" as you go; being careful not to allow the Tungsten to contact the puddle or rod.
- To stop welding, pull the Tip back over the weld approx. 1/2" [13mm] then lift to break the arc. Keep shielding gas flow in place for approx. 10 seconds.
- Keep in mind that you **MUST** let the shielding gas flow over the weld for approx. 10 seconds. Failure to do so will allow the welded area to oxidize as it cools, compromising the weld integrity.
- Constantly be aware that TIG welding quickly generates heat in the work piece and Torch. Severe burns can quickly occur by contacting hot metal pieces.
- When done, shut off the Power Switch, close the Regulator in the Torch Handle then close the Shielding Gas Tank valve completely.

## SPOOL GUN SET-UP AND WELDING

(Spool Gun available separately, not included)

### SPOOL GUN WELDING SET-UP

The Eastwood MP140i is designed to use an Eastwood #20645 Spool Gun (available separately, not included) which allows for easy feeding of aluminum wire to expand your welding capabilities. This is an optional accessory and can be purchased separately from Eastwood.

- Turn off Welder and unplug from power source.
- Open the side door of the Welder, disconnect the MIG Shielding Gas line at the Quick Disconnect, then insert the Quick-Disconnect fitting of the Spool Gun Shielding Gas Line through the access hole at the center of the lower front panel and connect it to the Quick Disconnect at the interior bulkhead panel (**FIG 22**).
- Disconnect the short Cable Lead from the Positive (+) Connection Receptacle by rotating the Rubber Insulator 1/2 turn Counter-Clockwise and pulling outward (**FIG 23**).
- Align the key of the brass ferrule of the Spool Gun Power Cable with the notch of the Positive (+) Connection Receptacle at the 12:00 position, then rotate 1/2 turn Clockwise to lock (**FIG 23**).
- Set the Selector Switch **[A]** located on the Front Panel to the "Spool Gun" Position.

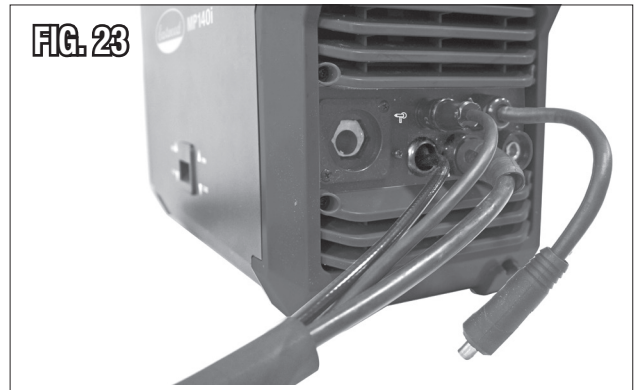
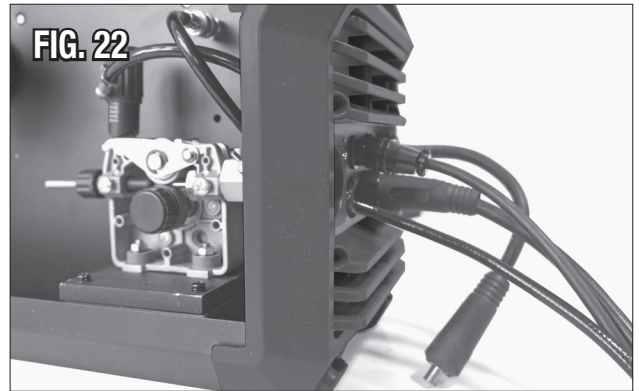



## THREADING WELDING WIRE THROUGH THE SPOOL GUN

- Push button to open Spool Gun Side Cover (FIG 24).
- Remove the Thumbscrew that retains the Wire Spool (FIG 25).  
**IMPORTANT NOTE:** Thumbscrew has Left-Hand threads.
- Place Wire Spool on Spindle and replace the Thumbscrew.
- Loosen the Wire Tensioning Screw (FIG 25) until it is possible to feed the welding wire through the drive roller grooves.
- Feed the wire by hand from the Spool into the Wire Inlet Guide, past the Drive Rollers and into the Wire Inlet Tube (FIG 25).
- Tighten the Wire Tensioner Thumb Screw (FIG 26) until it applies light pressure onto the welding wire.  
**NOTE:** If this is too tight it will deform the wire and cause feeding issues, if it is too loose the drive roller will slip on the wire.
- Remove the Nozzle and Contact Tip.
- Close the Spool Gun Side Cover.
- Plug in Welder to power source and turn on the Welder.
- Trigger the Spool Gun to feed the wire and adjust the Wire Tensioner Thumb Screw (FIG 26) so that the wire does not slip.
- Replace Contact Tip and Nozzle.
- Feed wire through the gun and cut the wire exposing a ~3/4" length beyond the contact tip.

## SPOOL GUN WELDING OPERATION

Your Eastwood MP140i can be used to weld aluminum utilizing a Spool Gun (Not Included). The Spool Gun is sold as an accessory to the MP140i, and you will also need to purchase a cylinder of 100% Argon gas from your local welding supplier. This following welding process is just a baseline to get you started.

- Refer to the 'Suggested Settings' chart which is located inside the side door of your Welder. From the chart select your baseline starting point for the recommended settings described in the chart.
- Ensure that the polarity is configured for DCEP welding.
- Set the process selector switch to MIG.
- Set the MIG / Spool Gun Selector Switch [A] to 'Spool Gun' on Front Panel.
- Connect your ground clamp to the work pieces that are to be welded. Make sure the ground clamp contacts are placed on a clean piece of metal free of paint, grease, rust, oils, etc. It is recommended to place your ground clamp as close to the weld area as possible.
- Assess your weld area and make sure the welding area is also cleaned of any paint, grease, rust, oils, etc. Aluminum has a layer of oxide on the surface that should be removed prior to welding.
- Plug in the Welder and turn the switch on the Rear Panel to the "ON" position.
- Open your gas valve on the bottle and adjust the flow rate if necessary.
- Depress the Spool Gun trigger for a few seconds pointing the welding gun away from your body and then let go of the trigger and cut the wire back to ~3/4" stick out length.
- Wearing your welding helmet, gloves, and long sleeve shirt and pants, put the end of the wire sticking out of the Spool Gun into the joint to be welded.
- Position the Spool Gun so that it is perpendicular to the base metal with 10-15° angle in the direction of push travel.
- Depress the trigger to start the wire feed which starts the arc.  
**NOTE:** When welding aluminum with a Spool Gun it is recommended to use a push technique. Using a drag technique will result in poor, dirty welds.
- When welding aluminum a spray arc transfer is preferred rather than short arc transfer that can be more commonly used on steels. This method involves using a longer wire stick out (~3/4"). When the Welder settings and technique have been dialed in the spray arc transfer should create a hissing sound and little or no spatter. Once positioned the trigger can be pulled and the weld started.
- Release the trigger on the Spool Gun to stop the weld.
- After welding is completed, close the valve completely on the Shielding Gas Bottle, turn Power Switch to the "OFF" position and unplug Welder.

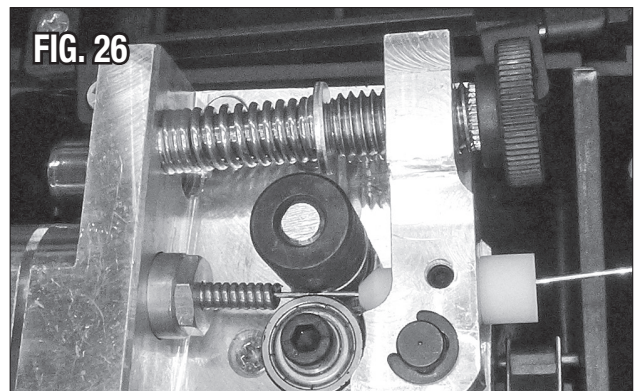
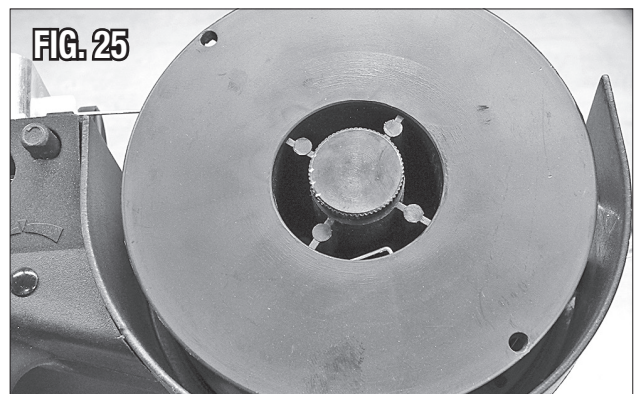
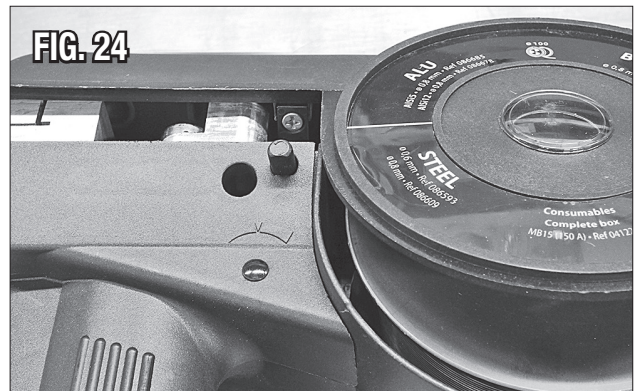

## OVERLOAD PROTECTION

Your Eastwood MP140i Welder is equipped with an overload breaker. This device will protect your Welder if the duty cycle is exceeded. If the output is exceeded, the internal breaker will trip and stop power supply to the drive motor although the fan will still run to cool the unit. If the breaker tripped resulting from an overload, the Overload Indicator LED [J] will illuminate AMBER. Allow the Welder to cool for a minimum of 15 minutes before attempting to resume welding.

## TYPES OF WELD JOINTS

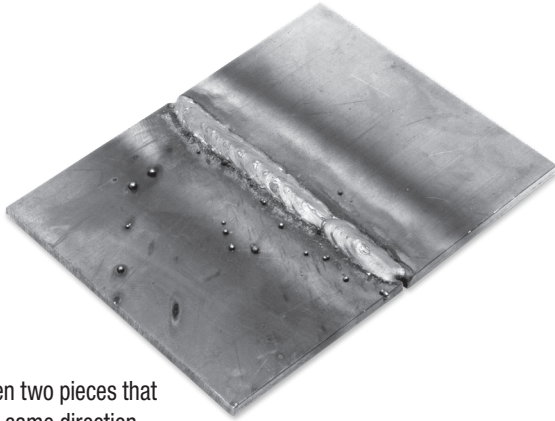

### BUTT WELD

is a joint between two pieces that are laying in the same direction.



### CORNER WELD

is a joint between two pieces that meet at or near perpendicular at their edges.



### EDGE WELD

is a joint between two pieces where the edges are being joined.

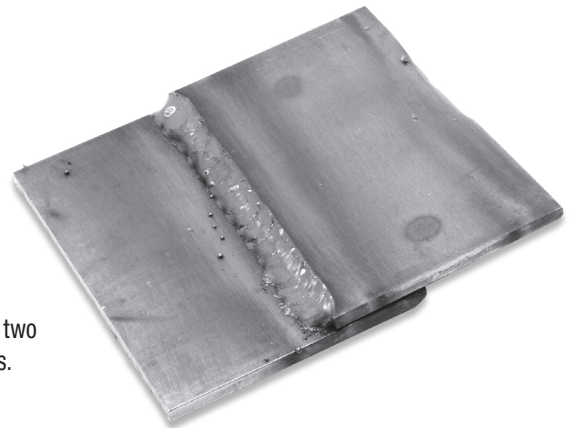

### LAP WELD

is a joint between two overlapping pieces.

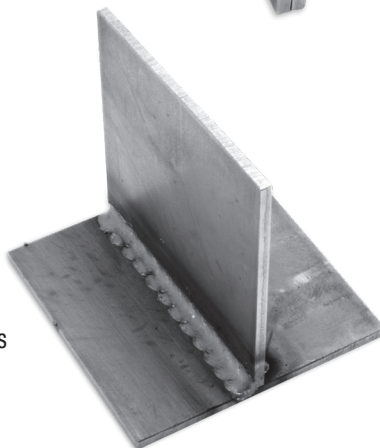

### TEE WELD

is a joint between two pieces where one is perpendicular to the other.

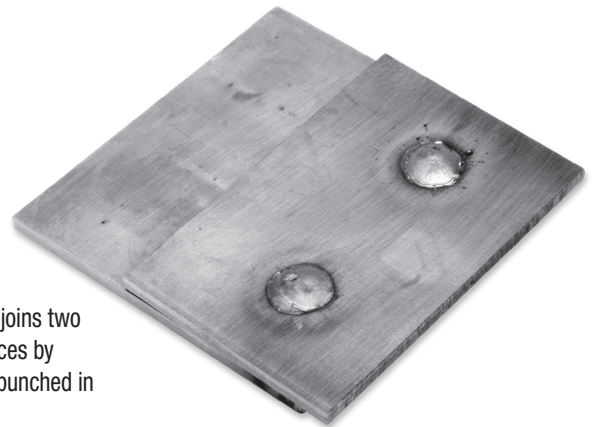

### PLUG WELD

is a joint which joins two overlapping pieces by filling in a hole punched in the top piece.

## STICK WELD TROUBLESHOOTING

PROBLEM	CAUSE	CORRECTION
Electrode Sticking	Arc Too Short	While welding, keep the ignited end of the electrode further from the weld joint.
	Current Too Low	Adjust the current on the front of the Welder to a higher current setting.
Holes in Weld Bead (Porosity)	Arc Too Long	While welding, keep the ignited end of the electrode closer to the weld joint.
	Moisture in Electrode	Replace electrode with a new one.
Excessive Spatter	Arc Too Long	While welding, keep the ignited end of the electrode closer to the weld joint,
	Current Too High	Adjust the current on the front of the welder to a lower current setting.
Poor Penetration	Poor Joint Preparation	Clean the weld joint of any dirt, grease, paint or other possible contaminants. If the pieces being Welder are of a heavy gauge it may be necessary to bevel the edges of the pieces.
	Current Too Low	Adjust the current on the front of the welder to a higher current setting.
	Travel Speed Too Fast	Slow down the travel speed of the electrode while welding.
Overload Light On	Duty Cycle Exceeded	Allow the Welder to cool for a minimum of 15 minutes before attempting to use again.

## MIG WELD TROUBLESHOOTING

PROBLEM	CAUSE	CORRECTION
Burn Through	High Voltage	Adjust voltage output to lower setting.
	Fast Wire Speed	Adjust wire speed to slower setting.
	Slow Gun Travel	Increase your travel speed with the Welding Gun.
Lack of Penetration	Low Voltage	Adjust voltage output to higher setting.
	Slow Wire Speed	Adjust wire speed to faster setting.
	Fast Gun Travel	Slow your travel speed of the Welding Gun making sure to pull or drag the molten metal puddle.
	Excessive Wire Protruding	Move the Contact Tip on the Welding Gun closer to the work piece to shorten the length of exposed wire.
	Material Too Thick	The MP200i is rated for a maximum thickness of 3/8", exceeding this will result in poor penetration.
	Poor Material Prep	If welding heavy gauge metals, it may be necessary to increase the welding gap between the two pieces and also bevel the edges on the weld side of the pieces.
Excessive Penetration	High Voltage	Adjust voltage output to lower setting.
	Fast Wire Speed	Adjust wire speed to slower setting.
	Slow Gun Travel	Increase your travel speed with the Welding Gun.
Warping	Lack of Tack Welds	Tack weld the pieces in multiple areas to keep the pieces from pulling apart.
	No Clamping	Use welding clamps to secure the pieces in the proper shape.
	Poor Technique	To prevent warping, allow the workpiece to cool after welding small sections at a time. Move your welding areas around by not completing all the welding in one section all at once, rather, welding a small amount in one area and then move to another section area to spread out the heat in the piece.



# TIG WELDING TROUBLESHOOTING

PROBLEM	CAUSE	CORRECTION
<b>Arc is Triggered but Will Not Start</b>	Incomplete Circuit	Check Ground connection. Make sure that the ground is on a freshly cleaned surface and close to the welding area. It is suggested to weld towards the ground connection.
	Incorrect Tungsten	Consult chart for proper Tungsten for the base metal being welded. In most cases Thoriated will be used for all steels.
	No Shielding Gas	Make sure the shielding gas cylinder is turned all the way open and set at the correct flow rate.
<b>Arc wanders and it is Hard to Concentrate Heat in a Specific Area</b>	Poorly Prepped Tungsten	Follow guidelines for prepping Tungsten.
	Poor Gas Flow	Adjust the flow rate of the shielding gas (refer to settings chart). Check for loose fittings where gas could be leaking.
	Contaminated Tungsten	Remove Tungsten from Torch, break off contaminated section, and sharpen.
	Incorrect Arc Length	Make sure the Tungsten is held 1/8 to 1/4 inch off the work piece.
	Incomplete Circuit	Check Ground connection. Make sure that the ground is on a freshly cleaned surface and close to the welding area. It is suggested to weld towards the ground connection.
	Contaminated Base Metal	Clean base metal making sure to remove any oil, debris, coatings, or moisture. If base metal is aluminum make sure all of the oxide is removed using either a dedicated stainless brush or flap wheel.
<b>Porosity in Weld Bead</b>	Poor Gas Flow	Adjust the flow rate of the shielding gas. Check for loose fittings where gas could be leaking.
	Contaminated Filler Metal	Clean filler metal making sure to remove any oil, debris, or moisture.
	Contaminated Base Metal	Clean base metal making sure to remove any oil, debris, coatings, or moisture.
	Poor Shielding	Make sure to be in an area with no wind and with any fans turned off. Wind or fans will blow the shielding gas away from the weld causing porosity.
	Incorrect Tungsten Exposure	Adjust the Tungsten so that 1/8" to 1/4" protrudes from the Collet.
<b>Contamination in Weld Bead</b>	Contamination Tungsten	Remove Tungsten from Torch and break off contaminated section and sharpen.
	Contaminated Filler Metal	Clean filler metal making sure to remove any oil, debris, or moisture.
	Contaminated Base Metal	Clean base metal making sure to remove any oil, debris, coatings, or moisture. If base metal is cold rolled steel make sure to remove any mill scale.
<b>Melting Tungsten</b>	Poor Gas Flow	Adjust the flow rate of the shielding gas. Check for loose fittings where gas could be leaking.
	Wrong Size Tungsten	Increase Tungsten diameter. Refer to chart for proper sizing.
	Incorrect Shielding Gas	Only use 100% Argon when TIG Welding.
<b>Poor Penetration</b>	Low Voltage	Voltage setting is too low for material/thickness. Increase as needed.
<b>Tungsten Contaminated</b>	Contact of Tungsten with Base Metal	Keep Tungsten 1/8 to 1/4" from the base metal. If Tungsten comes in contact break off end and sharpen immediately.
<b>Poor Weld Appearance</b>	Incorrect Positioning	The angle between the filler metal and the Torch must be less than 90 degrees otherwise the filler metal will prematurely melt and glob off causing poor weld appearance.



# TIG WELDING TROUBLESHOOTING

PROBLEM	CAUSE	CORRECTION
<b>Crater in the End of the Weld Bead</b>	Insufficient Shielding	Keep the Torch on the base metal while the post flow shielding gas flows to protect and cool the metal and Tungsten.
	Not Enough Filler Material	Reduce current and add more filler at end of weld. It may also be beneficial to back step to ensure no crater will form.
<b>Weld Bead is Cracking</b>	Too Much Heat in Material	Reduce heat and allow more time between passes.
	Base Metal is Absorbing Too Much Heat	Preheat base metal (consult welding codes for requirements)
	Incorrect Filler Wire	Use appropriate filler wire type and diameter for the joint being welded.
<b>Material is Warping</b>	Insufficient Clamping	Clamp work piece tightly and weld while clamps are in place.
	Insufficient Tack Welds	Add more tack welds until rigidity and stiffness is developed.
	Too Much Heat in Material	To reduce heat it is best to spread the welding out around the area. This can be done by using stitch welding techniques, alternating sides, and/or taking your time and allowing the pieces to cool between passes.

# WELDER ELECTRICAL SCHEMATIC

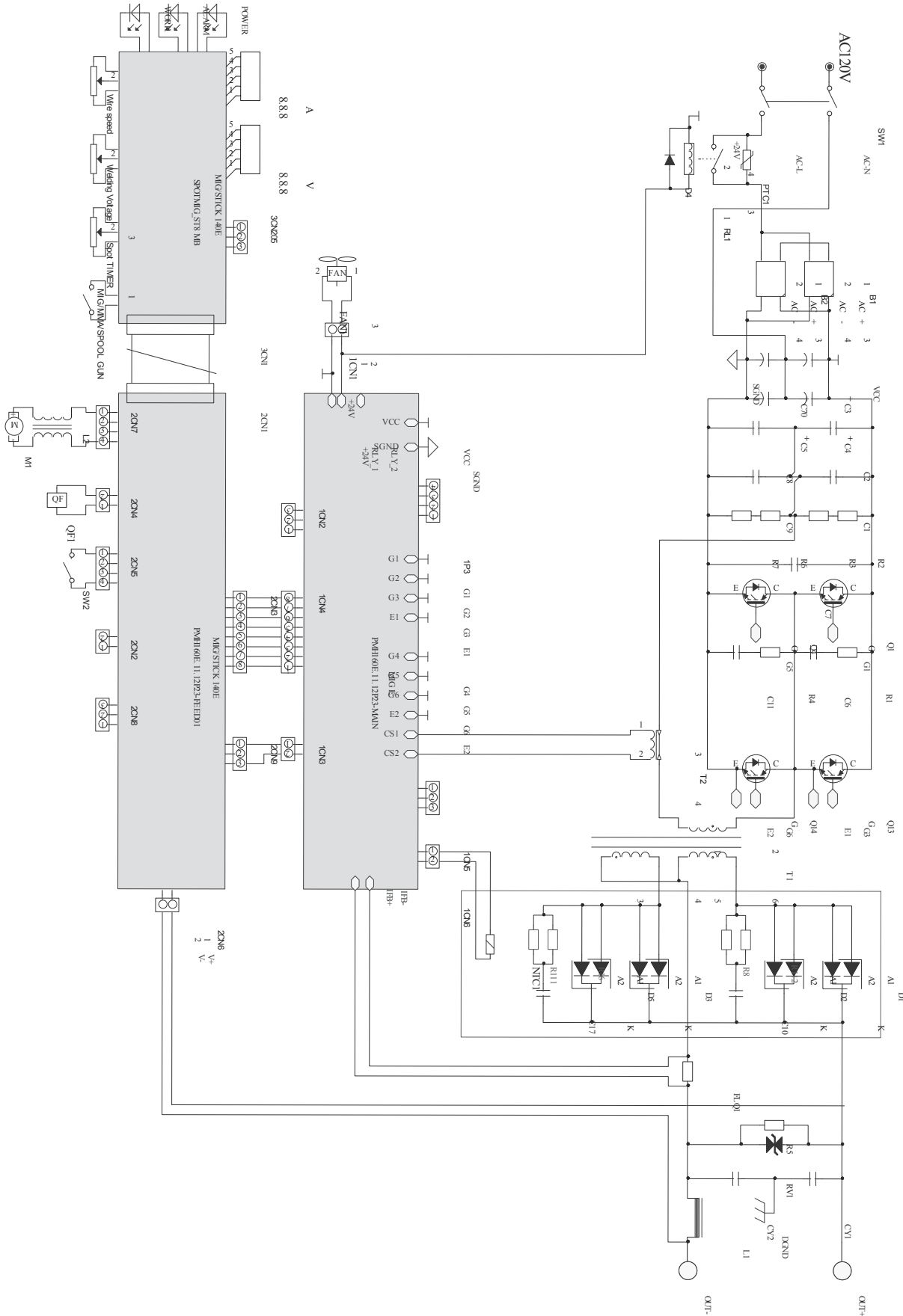





# ACCESSORIES

## CONSUMABLE ITEMS

- #12224 0.030" Contact Tips (5 Pack)
- #12211 0.025" Contact Tips (5 Pack)
- #20412 0.035" Contact Tips (5 Pack)
- #12225 0.030" Flux Core Wire, 2lbs, 4" Spool
- #12227 0.030" Solid MIG Wire, 2lbs, 4" Spool
- #20176 1/16" E3 "Purple" Tungsten, 2 pk.
- #20177 1/32" E3 "Purple" Tungsten, 2 pk.

## OPTIONAL ITEMS

- #12236 Welding Cart
- #11616 Deluxe MIG / TIG / Plasma Welding Cart
- #13203 Auto Darken Welding Helmet
- #13212 Large View Auto Darken Welding Helmet
- #12957 Welding Helmet Bag
- #12589/12590 Top Grain Cowhide 4" Cuff Welding Gloves (M/L)
- #12762 L/XL/XXL Welding Jacket
- #20645 Spool Gun
- #21525 Eastwood Tungsten Grinder
- #13953 Eastwood TIG Accessories Kit
- #20639 10' Long Ground Cable Extension

---

**If you have any questions about the use of this product, please contact**

The Eastwood Technical Assistance Service Department: 800.343.9353 >> email: [tech@eastwood.com](mailto:tech@eastwood.com)

PDF version of this manual is available at [eastwood.com](http://eastwood.com)

The Eastwood Company 263 Shoemaker Road, Pottstown, PA 19464, USA 800.343.9353 [eastwood.com](http://eastwood.com)

© Copyright 2020 Eastwood Automotive Group LLC 1/20 Instruction item #20559Q Rev 5