

Eastwood®

DO THE JOB RIGHT.®

Item #20589

TIG200 DIGITAL WELDER

ASSEMBLY & OPERATING INSTRUCTIONS



The **EASTWOOD TIG 200 DIGITAL WELDER** provides the ability to TIG or Stick weld all from a single compact, space-saving unit. Inverter Technology provides the capability of welding thin or heavy gauge steel and aluminum with precision and ease.

READ AND UNDERSTAND ALL INSTRUCTIONS AND PRECAUTIONS BEFORE PROCEEDING.

This unit emits powerful high current and extreme heat which can cause severe burns, dismemberment, electrical shock and death. Eastwood shall not be held liable for consequences due to deliberate or unintentional misuse of this product.

STATEMENT OF LIMITED WARRANTY

The Eastwood Company (hereinafter "Eastwood") warrants to the end user (purchaser) of all new welding and cutting equipment (collectively called the "products") that it will be free of defects in workmanship and material. This warranty is void if the equipment has been subjected to improper installation, improper care or abnormal operations.

WARRANTY PERIOD:

All warranty periods begin on the date of purchase from Eastwood. Warranty Periods are listed below, along with the products covered during those warranty periods:

3 Year Warranty on Material, Workmanship, and Defects:

- Eastwood TIG200 Digital Welder

Items not covered under this warranty: Collets, Collet Bodies, electrodes, nozzles, and ground clamp and cable. All other components are covered by the warranty and will be repaired or replaced at the discretion of Eastwood.

2 Years:

- All Welding Helmets.

CONDITIONS OF WARRANTY TO OBTAIN WARRANTY COVERAGE:

Purchaser must first contact Eastwood at 1-800-345-1178 for an RMA# before Eastwood will accept any welder returns. Final determination of warranty on welding and cutting equipment will be made by Eastwood.

WARRANTY REPAIR:

If Eastwood confirms the existence of a defect covered under this warranty plan, Eastwood will determine whether repair or replacement is the most suitable option to rectify the defect. At Eastwood's request, the purchaser must return, to Eastwood, any products claimed defective under Eastwood's warranty.

FREIGHT COSTS:

The purchaser is responsible for shipment to and from Eastwood.

WARRANTY LIMITATIONS:

EASTWOOD WILL NOT ACCEPT RESPONSIBILITY OR LIABILITY FOR REPAIRS UNLESS MADE BY EASTWOOD. EASTWOOD'S LIABILITY UNDER THIS WARRANTY SHALL NOT EXCEED THE COST OF CORRECTING THE DEFECT OF THE EASTWOOD PRODUCT. EASTWOOD WILL NOT BE LIABLE FOR INCIDENTAL OR CONSEQUENTIAL DAMAGES (SUCH AS LOSS OF BUSINESS, ETC.) CAUSED BY THE DEFECT OR THE TIME INVOLVED TO CORRECT THE DEFECT. THIS WRITTEN WARRANTY IS THE ONLY EXPRESS

WARRANTY PROVIDED BY EASTWOOD WITH RESPECT TO ITS PRODUCTS. WARRANTIES IMPLIED BY LAW SUCH AS THE WARRANTY OF MERCHANTABILITY ARE LIMITED TO THE DURATION OF THIS LIMITED WARRANTY FOR THE EQUIPMENT INVOLVED. THIS WARRANTY GIVES THE PURCHASER SPECIFIC LEGAL RIGHTS.

THE PURCHASER MAY ALSO HAVE OTHER RIGHTS WHICH VARY FROM STATE TO STATE.

IMPORTANT NOTE

These instructions are intended only to provide the user with some familiarity of the Eastwood TIG 200 Digital. TIG welding is a highly complex procedure with many variables. If you have no experience with TIG welding; it is extremely important to seek the advice of someone experienced in TIG welding for instruction, enroll in a local technical school welding course or study a comprehensive how-to DVD and obtain a good quality reference book on TIG welding as there is a moderate learning curve necessary before achieving proficiency in TIG Welding. Before attempting to use this unit on an actual project or object of value, practice on a similar material as there are many variables present and settings required when TIG welding different metals such as steel and stainless steel. It is also strongly recommended that the user adhere to the American Welding Society guidelines, codes and applications prior to producing welds where safety is affected.

SAFETY INFORMATION

Welding can be dangerous to you and other persons in the work area. Read and understand this instruction manual before using your Eastwood welding machine. Injury or death can occur if safe welding practices are not followed. Safety information is set forth below and throughout this manual.

To learn more about welding safety, read OSHA Title 29 CFR 1910, available at www.osha.gov; ANSI Z49.1, "Safety in Welding, Cutting and Allied Processes", available at www.aws.org; and the consumable manufacturer's Safety Data Sheet.

The following explanations are displayed in this manual, on the labeling, and on all other information provided with this product:

DANGER

DANGER indicates a hazardous situation which, if not avoided, will result in death or serious injury.

WARNING

WARNING indicates a hazardous situation which, if not avoided, could result in death or serious injury.

CAUTION

CAUTION used with the safety alert symbol, indicates a hazardous situation which, if not avoided, could result in minor or moderate injury.

NOTICE

NOTICE is used to address practices not related to personal injury.

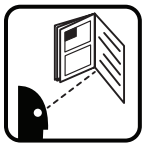

READ INSTRUCTIONS

- Thoroughly read and understand this manual before using.
- Save for future reference.



WARNING ELECTRIC SHOCK CAN CAUSE INJURY OR DEATH!

- Improper use of an electric Welder can cause electric shock, injury and death! Read all precautions described in the Welder Manual to reduce the possibility of electric shock.
- Disconnect Welder from power supply before assembly, disassembly or maintenance of the torch, contact tip and when installing or removing nozzles.
- Always wear dry, protective clothing and leather welding gloves and insulated footwear. Use suitable clothing made from durable flame-resistant material to protect your skin.
- If other persons or pets are in the area of welding, use welding screens to protect bystanders from sparks.
- Always operate the Welder in a clean, dry, well ventilated area. Do not operate the Welder in humid, wet, rainy or poorly ventilated areas.
- The electrode and work (or ground) circuits are electrically "hot" when the Welder is on. Do not allow these "hot" parts to come in contact with your bare skin or wet clothing.
- Separate yourself from the welding circuit by using insulating mats to prevent contact from the work surface.
- Be sure that the work piece is properly supported and grounded prior to beginning an electric welding operation.
- Always attach the ground clamp to the piece to be welded and as close to the weld area as possible. This will give the least resistance and best weld.



WARNING WELDING SPARKS CAN CAUSE FIRE OR EXPLOSION!

- Electric welding produces sparks which can be discharged considerable distances at high velocity igniting flammable or exploding vapors and materials.
DO NOT operate electric arc Welder in areas where flammable or explosive vapors are present.
DO NOT use near combustible surfaces. Remove all flammable items **from the work area where welding sparks can reach (minimum of 35 feet)**.
- Always keep a fire extinguisher nearby while welding.
- Use welding blankets to protect painted and or flammable surfaces; rubber weather-stripping, dash boards, engines, etc.
- Ensure power supply has properly rated wiring to handle power usage.

SAFETY INFORMATION



⚠ WARNING ELECTROMAGNETIC FIELDS CAN BE A HEALTH HAZARD!

- The electromagnetic field that is generated during arc welding may interfere with various electrical and electronic devices such as cardiac pacemakers. Anyone using such devices should consult with their physician prior to performing any electric welding operations.
- Exposure to electromagnetic fields while welding may have other health effects which are not known.



⚠ WARNING ARC RAYS CAN INJURE EYES AND BURN!

- Arc rays produce intense ultraviolet radiation which can burn exposed skin and cause eye damage. Use a shield with the proper filter **(a minimum of #11)** to protect your eyes from sparks and the rays of the arc when welding or when observing open arc welding (see ANSI Z49.1 and Z87.1 for safety standards).
- Use suitable clothing made from durable flame-resistant material to protect your skin.
- If other persons or pets are in the area of welding, use welding screens to protect bystanders from sparks and arc rays.



⚠ WARNING FUMES AND WELDING GASES CAN BE A HEALTH HAZARD!

- Fumes and gasses released during welding are hazardous. Do not breathe fumes that are produced by the welding operation.
- Prolonged inhalation of welding fumes above safety exposure limits can injure the lungs and other organs.
- Use enough ventilation and/or exhaust at the arc to keep fumes and gases from your breathing area.
- Use an OSHA approved respirator when welding in confined spaces or where there is inadequate ventilation.
- Never weld coated materials including but not limited to: cadmium plated, galvanized, lead based paints.



⚠ CAUTION HOT METAL AND TOOLS WILL BURN!

- Electric welding heats metal and tools to temperatures that will cause severe burns!
- Use protective, heat resistant gloves and clothing when using Eastwood or any other welding equipment. Never touch welded work surface, torch tip or nozzle until they have completely cooled.



⚠ CAUTION FLYING METAL CHIPS CAN CAUSE INJURY!

- Grinding and sanding will eject metal chips, dust, debris and sparks at high velocity. To prevent eye injury wear approved safety glasses.
- Wear an OSHA-approved respirator when grinding or sanding.
- Read all manuals included with specific grinders, sanders or other power tools used before and after the welding process. Be aware of all power tool safety warnings.



⚠ NOTICE FIRST AID

- If exposed to excessive fumes move to an area with fresh air. Follow safety information on manufacturer's Safety Data Sheet.
- For other injuries follow basic first aid techniques and call a physician or emergency medical personnel.

WELDER SPECIFICATIONS

The TIG 200 DIGITAL is capable of these 7 types of welding processes:

- 1) Manual Arc (Stick)
- 2) DC TIG
- 3) DC TIG/Pulse
- 4) AC TIG
- 5) AC TIG/Pulse
- 6) AC TIG/MIX
- 7) TIG/Spot

Input – Single Phase				
Standard Voltage / Phase / Frequency			240V (+/-10%) / 1 / 50/60 HZ	
Rated Max. Input Power			8.1 kW (Arc mode) 7.2 kW (TIG mode)	
Recommended Fuse or Breaker Size			50A	
Arc	Rated Max. Supply Current	34A	Max. Effective Supply Current	15A
TIG		30A		15A

Rated Output – DC Only				
Welding Mode		Duty Cycle ⁽¹⁾	Amperes	Volts at Rated Amperes
Input 240V	Arc	20%	170A	26.8V
		60%	98A	23.9V
		100%	76A	23V
	TIG	25%	200A	18V
		60%	129A	15.2V
		100%	100A	14V

Output Range				
Input Power	Welding Mode	Welding Current Range	Open Circuit	Welding Voltage Range
240V	Arc	10A ~ 170A	68V	20.4V ~ 26.8V
	TIG	10A ~ 200A	13V (VRD)	10.4V ~ 18V

Temperature Range	
Operating Temperature Range	-10°C ~ +40°C (14°F ~ 104°F)
Storage Temperature Range	-25°C ~ +55°C (-13°F ~ 131°F)

DUTY CYCLE

The rated Duty cycle refers to the amount of welding that can be done within an amount of time. The Eastwood TIG 200 Digital has a duty cycle of 25% at 200 Amps. It is easiest to look at your welding time in blocks of 10 Minutes and the Duty Cycle being a percentage of that 10 Minutes. If welding at 200 Amps with a 25% Duty Cycle, within a 10 Minute block of time you can weld for 2 Minutes, 30 Seconds with 7 Minutes, 30 seconds of cooling for the Welder.

If the Duty Cycle is exceeded, the Welder will automatically shut off, however the fan will continue running to cool the internal components.

When a safe temperature has been reached, the Welder will automatically switch the Welder output back on. To increase the duty cycle you can turn down the Amperage Output control.

REQUIRED ITEMS

Before you begin using the Eastwood TIG 200 Digital Welding System, make sure you have the following:

1. The Eastwood TIG 200 Digital is supplied with the popular NEMA 6-50P plug, requiring a NEMA 6-50R receptacle.
2. A clean, safe, well-lit, dry and well-ventilated work area.
3. A non-flammable, long sleeve shirt or jacket.
4. Heavy Duty Welding Gloves.
5. An Auto Darkening Welding Mask to provide eye protection during welding operations.
NOTE: MUST be a #11 lens or darker.
6. A compressed gas cylinder containing 100% Argon (must be used when TIG welding and is available at any welding supply facility).
7. Dedicated stainless steel wire welding brush for each material to be welded.
8. A dedicated fine grit synthetic stone grinding wheel or a Tungsten Sharpener.

POWER REQUIREMENTS

The Eastwood TIG 200 DIGITAL requires a 220-240 VAC 50/60Hz., 50 Amp circuit.

BEFORE YOU BEGIN

Remove all items from the box. Compare with list below to make sure unit is complete.

- | | |
|---------------------------------------------------------|---------------------------------|
| (1) Eastwood TIG 200 DIGITAL Welder with NEMA6-50P Plug | (1) 3/32" Collet Body |
| (1) Shielding Gas Regulator | (1) 1/16" Collet Body |
| (1) Shielding Gas Hose, 4.6' [1.4m] | (1) 3/32" Collet |
| (1) Ground Cable with Clamp, 13' [4m] | (1) 1/16" Collet |
| (1) Flexible TIG Torch (WP17F) with 14' [4.2m] cable | (1) 3/32" Gray Tungsten |
| (1) Foot Pedal | (1) 1/16" Gray Tungsten |
| (1) #6 Gas Nozzle (3/8") | (1) Eastwood Instruction Manual |
| (1) #5 Gas Nozzle (5/16") | |
| (1) Long Back Cap | |
| (1) Short Back Cap | |

FRONT PANEL CONTROLS AND DISPLAYS

The Eastwood Digital Front Panel is arranged with 6 major groups of Function Switches with LED Indicators. They are as follows:

1. Welding Modes
2. Welding Function
3. Arc Start
4. 2T/4T Switch
5. Data Loading
6. Recall/Remote

In addition, the Dual-Function Knob is rotated to select programs and increase/decrease values and is pushed to lock-in settings.

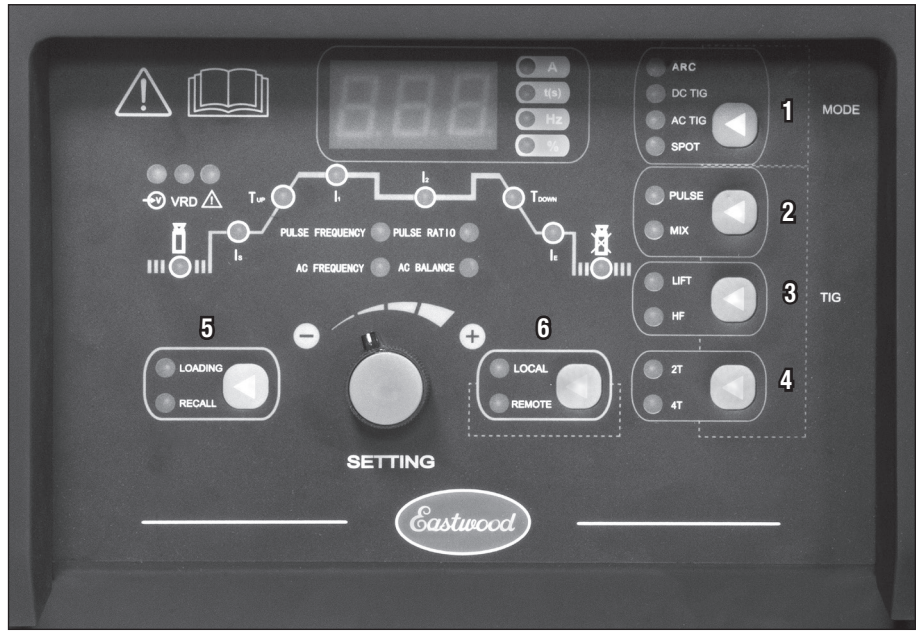

FUNCTION SWITCH OPERATION

(1) WELDING MODES SWITCH:

- Arc
- DC TIG
- AC TIG
- Spot

(2) WELDING FUNCTIONS SWITCH:

- **Pulse:** (output current will be variable periodically based on the preset pulse frequency and base current)
- **MIX:** (AC square wave current will be inserted by a DC current to stabilize arc)

(3) ARC START SWITCH:

- **LIFT:** TIG operation with scratch start method.
- **HF:** TIG operation with High frequency start method so operator doesn't require the electrode to touch workpiece.

(4) 2T/4T SWITCH:

- **2T:** For 2-step operation of short welding.
 - 1) Depress trigger and hold in. Pre-flow begins if selected. Arc begins at selected start-amps and amperage increases at slope-up setting. If slope-up and pre-flow settings are zero, the arc begins immediately at full set amperage.
 - 2) To end arc, release trigger and amperage will slope-down at rate selected. If slope-down is zero, the arc will stop as soon as trigger is released. Post-flow always occurs and extends for as long as pre-selected.
- **4T:** For 4-step operation of long welding.
 - 1) Depress trigger and hold in. Pre-flow begins if selected. Amps rise only to initial amp setting and allows you to make final adjustments before delivering main amperage setting.
 - 2) Releasing trigger causes main amperage to slope-up to set value. If slope-up is set to zero, amps raise to main value instantly. Zero slope-up is best for thicker metal and clear anodized aluminum.
 - 3) Depress trigger once again and hold to complete weld. Amperage will decrease according to set slope-down value and will hold at your set end amps value until trigger is released.
 - 4) Releasing trigger at this point will stop arc however post-flow shielding gas continues for as long as determined by the preset interval.

(5) DATA LOADING AND RECALL SWITCH:

- **Loading:** (20 set modes can be saved).
- **Recall:** (operator can access previously saved procedures).

(6) LOCAL/REMOTE SWITCH:

- **Local:** Torch Switch.
- **Remote:** Foot Pedal use.

DUAL-FUNCTION KNOB (SETTING)

The Dual-Function Knob operates by both turning and pushing in. Turn for selecting program and raising or lowering numerical values. Push to lock in setting and exit program.

FUNCTION SETTING PROCEDURE (APPLIES TO ALL 6 FUNCTION SWITCHES):

- 1) Select Program Function: Rotate the Dual-Function Knob to select program for setting (The indicated LED will illuminate).
- 2) Push the Dual-Function Knob to start the setting process. **NOTE:** the default setting LEDs are illuminated.
- 3) Adjust numeric values: Push the Dual-Function Knob again, the selected LED will illuminate and the numerical value will blink, then turn the Dual-Function Knob as required to raise/lower the numeric values.
- 4) Lock-in Setting: Push the Dual-Function Knob once again to lock-in the desired numeric values. The selected LED remains illuminated.
- 5) Exit Function Program: Push the Dual-Function Knob once again, the selected LED will go out, and the function program is completed

DIGITAL READOUT DISPLAY

- A = Current
- S = Time
- HZ = Frequency
- % = Balance

ON/OFF SWITCH

The ON/OFF Switch is located on the upper rear panel of the Welder (**FIG. 5**).

SETTING FUNCTION PARAMETERS

IMPORTANT NOTE: These instructions are intended only to provide the user with some familiarity of the Eastwood TIG 200 Digital. TIG welding is a highly complex procedure with many variables. If you have no experience with TIG welding; it is extremely important to seek the advice of someone experienced in TIG welding for instruction, enroll in a local technical school welding course or study a comprehensive how-to DVD and obtain a good quality reference book on TIG welding as there is a moderate learning curve necessary before achieving proficiency in TIG Welding. Before attempting to use this unit on an actual project or object of value, practice on a similar material as there are many variables present and settings required when TIG welding different metals such as steel and stainless steel. It is also strongly recommended that the user adhere to the American Welding Society guidelines, codes and applications prior to producing welds where safety is affected.

5 BASELINE PRE-SETS

TIG Presets Table								
Preset	Process	Preflow	Base Current	Current	Posts Flow	AC Frequency	Polarity	AC Balance
P1	Steel Sheet Metal	0.4	10	80	5	NA	DC	NA
P2	Steel 1/8"	0.4	20	150	5	NA	DC	NA
P3	Aluminum 1/16"	0.4	10	75	5	120	AC	20
P4	Aluminum 1/8"	0.4	20	140	5	100	AC	20
P5	Aluminum 3/16"	0.4	20	175	5	100	AC	20

TIG/DC SETTINGS

SETTING PARAMETERS

Select the TIG /DC mode, DC welding function, LIFT/HF, 2T/4T, adjust the pre-gas time, arc current, slope up time, peak current, slope down time, crater current, slope down time.

- 1. Pre-Flow Time Setting:** In order to prevent workpiece or tungsten contamination and burnout, set the Pre-Flow time to allow the argon gas to push out the ambient air in the torch. The Pre-Flow provides protection for the area where the welding pool will be formed. It also improves stability when the welding arc is created.
- 2. Arc Current Setting:** Generally, the Arc Current is set lower than the max current.
- 3. Slope-Up Time Setting:** This is an optional setting that provides ramp-up from minimum current to welding current.
- 4. Max Current:** This is the welding current. Set the current by referring to the TIG/DC Welding Table. (See Below).
- 5. Slope-down Time Setting:** Time needed to shift from Welding Current to Minimum Current. This is an optional setting that helps avoid cracks and craters at the end of welding.
- 6. Crater Current Setting:** Generally, the Arc Current is set lower than the max current.
- 7. Post-Flow Time Setting:** In order to prevent workpiece or tungsten contamination and burnout, set the Post-Flow Time to allow the Argon gas to remain in the torch. It protects the weld puddle and the electrode against oxidization while the metal is cooling after welding.

TIG/DC WELDING TABLE					
Material	Workpiece Thickness (mm)	Ø Electrode (mm)	Ø Rod (filler metal (mm)	Current (amps)	Flow Rate (Argon cfh)
Stainless Steel	0.6	1.0, 1.6	~1.6	20 ~ 40	8.5
	1.0	1.0, 1.6	~1.6	30 ~ 60	8.5
	1.6	1.6, 2.4	~1.6	60 ~ 90	8.5
	2.4	1.6, 2.4	1.6 ~ 2.4	80 ~ 120	8.5
	3.2	2.4, 3.2	2.4 ~ 3.2	110 ~ 150	11
	4.0	2.4, 3.2	2.4 ~ 3.2	130 ~ 180	13
	4.8	2.4, 3.2, 4.0	2.4 ~ 4.0	150 ~ 220	13
Aluminum (AC)	6.4	3.2, 4.0, 4.8	3.2 ~ 4.8	180 ~ 250	13
	1.0	1.6	~1.6	50 ~ 60	15
	1.6	1.6, 2.4	~1.6	60 ~ 90	15
	2.4	1.6, 2.4	1.6 ~ 2.4	80 ~ 110	15
	3.2	2.4, 3.2	2.4 ~ 4.0	100 ~ 140	15
	4.0	3.2, 4.0	3.2 ~ 4.8	140 ~ 180	15
	4.8	3.2, 4.0, 4.8	4.0 ~ 6.4	170 ~ 220	15
6.4	4.0, 4.8	4.0 ~ 6.4	200 ~ 270	25	

TIG/DC/PULSE

PULSE SETTINGS

Select the TIG /DC mode Pulse Welding function, LIFT/HF, 2T/4T, adjust the Pre-Flow time, arc current, slope-up time, peak current, base current, slope-down time, crater current, slope-down time, pulse frequency and pulse ratio.

- 1. Base Current Setting:** Generally set in a lower value to avoid breaking the arc.
- 2. Pulse Ratio Setting:** The Pulse Ratio determines the linear input, the higher the ratio is, the wider and deeper the weld is and vice versa. Generally, set the ratio between 30%-70%.
- 3. Pulse Frequency Setting:** The higher the frequency it is, the denser the weld seam is and vice versa.

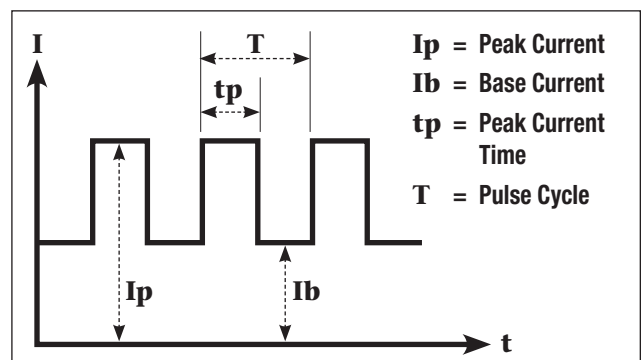

TIG/DC/PULSE Table 1

Material	Joint Shape	Gap (mm)	Pulse Condition				Welding Speed In/Min	Feed Speed Ft/Min
			Peak Current	Base Current	Pulse Frequency (HZ)	Pulse Ratio %		
Mild Steel		0	200	50	2.5	50	24	2
		1.2	150	20	1.5	45	12	2
		1.6	130	20	1	50	6	1.25
Stainless Steel		0	150	50	3	50	32	1.25
		1.2	150	20	1	35	6	1.25
		1.6	130	20	0.8	30	4	1.25
		2.0	130	20	0.8	30	32	0

TIG/DC/PULSE Table 2

Material	Joint Shape	Gap (mm)	Pulse Condition				Welding Speed In/Min	Feed Speed Ft/Min
			Max Current	Base Current	Pulse Frequency (HZ)	Pulse Ratio %		
Mild Steel		1	250	50	0.8	20	4	2
Stainless & Mild Steel		1	170	60	2.5	50	20	2
Mild Steel		1	120	50	2	50	8	1
Stainless Steel		1	160	50	1.5	45	3	2

TIG/AC

SETTING PARAMETERS

Select the TIG /AC mode function, LIFT/HF, 2T/4T, adjust the pre-flow time, arc current, slope up time, peak current, slope down time, crater current, slope down time, AC frequency, AC balance.

- AC Frequency setting:** The higher the frequency is, the arc is more intense and concentrated, the weld seam is smoother, however the arc sound is much higher pitched. Lower AC Frequency is generally suggested.
- AC Balance setting:** Is the percentage of time the current is electrode positive. The higher this percentage is, the smoother the weld seam will be however, the weld penetration will be shallower and the tungsten wears much faster. Lower AC Balance Ratio is generally suggested.

TIG/AC/PULSE

SETTING PARAMETERS

Select the TIG /AC mode function, LIFT/HF, 2T/4T, adjust the pre-flow time, arc current, slope up time, peak current, slope down time, crater current, slope down time, AC frequency, AC balance.

TIG/AC/PULSE Table 2									
Material	Joint Shape	Thickness	Pulse Condition				Filler Metal		
			Peak Current	Base Current	Pulse Frequency (HZ)	Pulse Ratio %	Diameter (mm)	Feed Speed Ft/Min	
Aluminum		1.0	70	25	1	50	1.6	2.5	
		1.5	80	40	1	50	1.6	3	
		1.5	90	25	1	50	1.6	2.5	
		1.5	85	25	1	50	1.2	3	
		3.2	170	25	1	50	1.2	9.5	
		3.0	170	25	1	50	1.6	5.5	
		6.0	220	25	1	50	1.6	8	
	First L	6.0	180	25	1	50	1.6		
	Second		180	25	1	50	1.6	8	
			6.0	120	50	2	50	8	1
			3.0	160	50	1.5	45	3	2

TIG/MIX

SETTING PARAMETERS

Select the TIG /AC mode MIX welding function, LIFT/HF , 2T/4T, adjust the pre-flow time, arc current, slope up time, peak current, slope down time, crater current, slope down time, AC frequency, AC balance.

AC welding 0.3s + DC welding 0.2s

TIG/SPOT

SETTING PARAMETERS

Select the SPOT mode, adjust the pre-flow time, slope up time (spot time), peak current, slope down time.

NOTE: In this mode, the Welder will operate in HF and 2T only.

SET UP AND OPERATION FOR TIG WELDING

SHIELDING GAS CONNECTION FOR TIG WELDING

⚠ WARNING BUILDUP OF GAS CAN INJURE OR KILL!

- Shut off shielding gas supply when not in use.
- Always ventilate confined spaces or use approved air-supplied respirator.
- Always turn your face away from valve outlet when opening cylinder valve.

⚠ WARNING CYLINDERS CAN EXPLODE IF DAMAGED!

Shielding gas cylinders contain gas under high pressure. If damaged, a cylinder can explode. As gas cylinders are a normal component of the welding process, use extra care to handle them carefully.

- Protect compressed gas cylinders from excessive heat, mechanical shocks, physical damage, slag, open flames, sparks and arcs. Keep away from any welding or other electrical circuits.
- Install cylinders in an upright position by securing to a specifically designed rack, cart or stationary support to prevent falling or tipping over.
- Never weld on a pressurized cylinder or explosion will occur.
- Use only correct shielding gas cylinders, regulators, hoses and fittings designed for the specific application; maintain them and all related components in good condition.
- Keep protective cap in place over valve except when cylinder is in use.
- Use proper equipment, procedures and have adequate help when moving or lifting cylinders.

A Shielding Gas Bottle is **NOT INCLUDED** with your Eastwood TIG 200 Digital but is necessary for TIG welding. A Shielding Gas Bottle can be bought at most local Welding Supply Stores. Eastwood recommends the use of 100% Argon shielding gas when TIG welding Steel, Stainless Steel, and Aluminum.

After connecting your Shielding Gas Regulator, the gas flow rate needs to be adjusted so that the proper amount of Shielding Gas is flowing over your weld. If there is too little gas flow there will be porosity in your welds as well as excessive spatter, if there is too much gas flow you will be wasting gas and may affect the weld quality.

- Place the Eastwood TIG 200 Digital in its dedicated area or on a welding cart.
- Secure your Shielding Gas Bottle to a stationary object or mount to your welding cart, if it is equipped to hold one, so that the cylinder cannot fall over.
- Remove the cap from the Shielding Gas Bottle.
- Insert the large brass male fitting on the Shielding Gas Regulator into the female fitting on the Shielding Gas Bottle (**FIG. 2**).
- Tighten the fitting with a wrench till snug, do not over tighten.
- Connect either end of the Gas Line included with your Eastwood TIG 200 Digital to the fitting on the regulator and tighten with a wrench until snug.
- Connect the other end of the gas line to the fitting on the rear of the Eastwood TIG 200 Digital and tighten with a wrench until snug (**FIG. 3**).

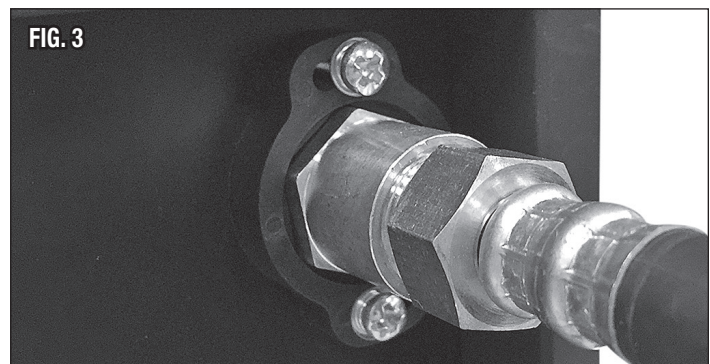
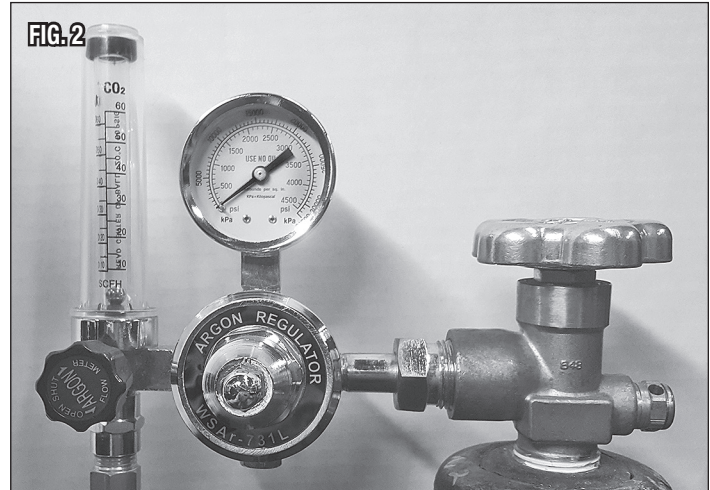

FIG. 4



TIG TORCH CONNECTION

- Connect the female brass fitting on the torch cable to the male brass fitting on the welder (**FIG 4**).
 - Use a wrench and tighten until snug. **DO NOT OVERTIGHTEN.**
 - Connect the black 5 pin plug to the Torch Switch/Foot Pedal Connection as shown in (**FIG 4**).
- NOTE:** Omit this step if you will be using the foot pedal for Amperage control.

GROUND CABLE CONNECTION

- Locate the Ground Cable and Clamp.
- The Ground Cable connection is located at the far right of the front panel as shown in (**FIG 4**). With the Key on the connector in the 12 O'clock position, insert the connector and turn 180° clockwise to lock in the connector.

FOOT PEDAL CONNECTION

- If you are going to be using the switch on the torch to start the welding arc, omit this step.
- Connect the Black 5 pin plug on the Foot Pedal to the Torch Switch/Foot Pedal Connection as shown in (**FIG 4**).

TIG WELDING

⚠ DANGER ELECTRIC SHOCK CAN CAUSE INJURY OR DEATH!

- Improper use of an electric Welder can cause electric shock, injury and death! Read all precautions described in the Welder Manual to reduce the possibility of electric shock.
- Disconnect Welder from power supply before assembly, disassembly or maintenance of the torch, contact tip and when installing or removing nozzles.
- Always wear dry, protective clothing and leather welding gloves and insulated footwear. Use suitable clothing made from durable flame-resistant material to protect your skin.
- If other persons or pets are in the area of welding, use welding screens to protect bystanders from sparks.
- Always operate the Welder in a clean, dry, well ventilated area. Do not operate the Welder in humid, wet, rainy or poorly ventilated areas.
- The electrode and work (or ground) circuits are electrically “hot” when the Welder is on. Do not allow these “hot” parts to come in contact with your bare skin or wet clothing.
- Separate yourself from the welding circuit by using insulating mats to prevent contact from the work surface.
- Be sure that the work piece is properly supported and grounded prior to beginning an electric welding operation.
- Always attach the ground clamp to the piece to be welded and as close to the weld area as possible. This will give the least resistance and best weld.

⚠ DANGER WELDING SPARKS CAN CAUSE FIRE OR EXPLOSION!

- Electric welding produces sparks which can be discharged considerable distances at high velocity igniting flammable or exploding vapors and materials.
 - DO NOT operate electric arc Welder in areas where flammable or explosive vapors are present.
 - DO NOT use near combustible surfaces. Remove all flammable items from the work area where welding sparks can each (minimum of 35 feet).
- Always keep a fire extinguisher nearby while welding.
- Use welding blankets to protect painted and or flammable surfaces; rubber weather-stripping, dash boards, engines, etc.
- Ensure power supply has properly rated wiring to handle power usage.

⚠ WARNING ELECTROMAGNETIC FIELDS CAN BE A HEALTH HAZARD!

- The electromagnetic field that is generated during arc welding may interfere with various electrical and electronic devices such as cardiac pacemakers. Anyone using such devices should consult with their physician prior to performing any electric welding operations.
- Exposure to electromagnetic fields while welding may have other health effects which are not known.

⚠ WARNING ARC RAYS CAN INJURE EYES AND BURN!

- Arc rays produce intense ultraviolet radiation which can burn exposed skin and cause eye damage. Use a shield with the proper filter (a minimum of #11) to protect your eyes from sparks and the rays of the arc when welding or when observing open arc welding (see ANSI Z49.1 and Z87.1 for safety standards).
- Use suitable clothing made from durable flame-resistant material to protect your skin.
- If other persons or pets are in the area of welding, use welding screens to protect bystanders from sparks and arc rays.

⚠ WARNING FUMES AND WELDING GASES CAN BE HEALTH HAZARD!

- Fumes and gasses released during welding are hazardous. Do not breathe fumes that are produced by the welding operation.
- Prolonged inhalation of welding fumes above safety exposure limits can injure the lungs and other organs.
- Use enough ventilation and/or exhaust at the arc to keep fumes and gases from your breathing area.
- Use an OSHA approved respirator when welding in confined spaces or where there is inadequate ventilation.
- Never weld coated materials including but not limited to: cadmium plated, galvanized, lead based paints.

⚠ CAUTION HOT METAL AND TOOLS WILL BURN!

- Electric welding heats metal and tools to temperatures that will cause severe burns!
- Use protective, heat resistant gloves and clothing when using Eastwood or any other welding equipment. Never touch welded work surface, torch tip or nozzle until they have completely cooled.

- Select the desired functions and settings as described in the FRONT PANEL CONTROLS AND DISPLAYS Section of this Manual.
- Connect the Welder to a power source. This Welder requires a minimum 50 Amp, 240 VAC, 50/60 Hz Protected Circuit.
- Turn the Power Switch on the rear panel of the Welder to the ON position (**FIG 5**).
- Slowly open the gas cylinder valve. **NOTE:** Always open valve fully to avoid shielding gas leakage.
- Grounding is very important, place the Ground Cable Clamp on a clean, bare area of your work piece as close to the welding area as possible to minimize the chance of shock. Scrape, wire brush, file or grind a bare area to achieve a good ground to assure safety.
- Use a dedicated stainless steel brush or flap-disc to clean the areas to be welded. Do not use the brush or flap-disc for any other purpose.
- Making sure all your safety gear is in place (Welding Mask, Welding Gloves, non-flammable long sleeve apparel) and the area is completely free of flammable material.
- Although it is a matter of developing a personal style, a good starting point for best results is achieved by holding the tip at a 45° angle backward and approx. 20° to the right of the weld. Hold the Filler Metal Rod at a 60° angle to the Tungsten Tip (**FIGS 6 & 7**). Never allow the Tungsten Tip to touch the welding surface or material rod. Doing so will quickly destroy the tip and contaminate the weld. If this happens, remove the Tungsten and regrind the tip. It is best to hold the Tungsten tip 1/8" from the surface.
- With your Welding Shield and all safety gear in place, practice "Forming a Puddle" with the Tungsten Tip. Once you become familiar with this step. Practice the "Dip and Pull" technique with the Filler Metal Rod and Torch (**FIG 7**) "Dip and Pull" is the practice of forming a puddle, moving the Torch while maintaining the puddle and adding filler rod metal to the puddle by "dipping and pulling" as you go; being careful not to allow the Tungsten to contact the puddle or rod.
- Keep in mind that you **MUST** let the shielding gas flow over the weld after releasing the trigger or pedal. Failure to do so will allow the welded area to oxidize compromising the weld integrity.
- Constantly be aware that TIG welding quickly generates heat in the work piece and torch. Severe burns can quickly occur by contacting hot metal pieces.
- When done, shut off the Power Switch and close the Shielding Gas Tank valve completely.

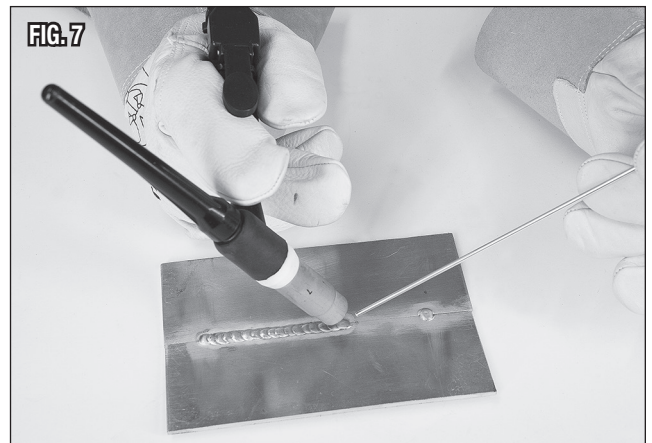
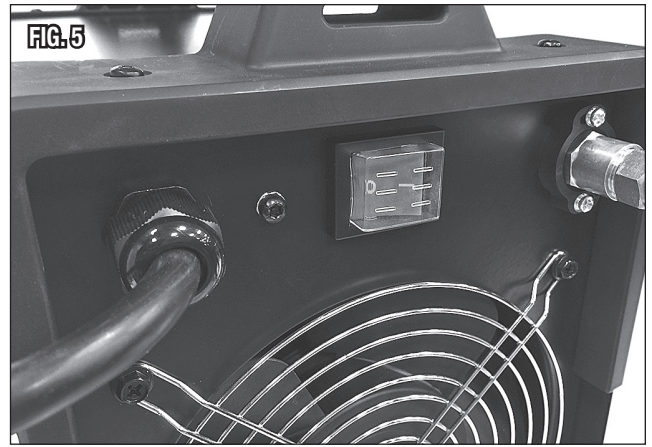

TIG TORCH ASSEMBLY/DISASSEMBLY

FIG. 8

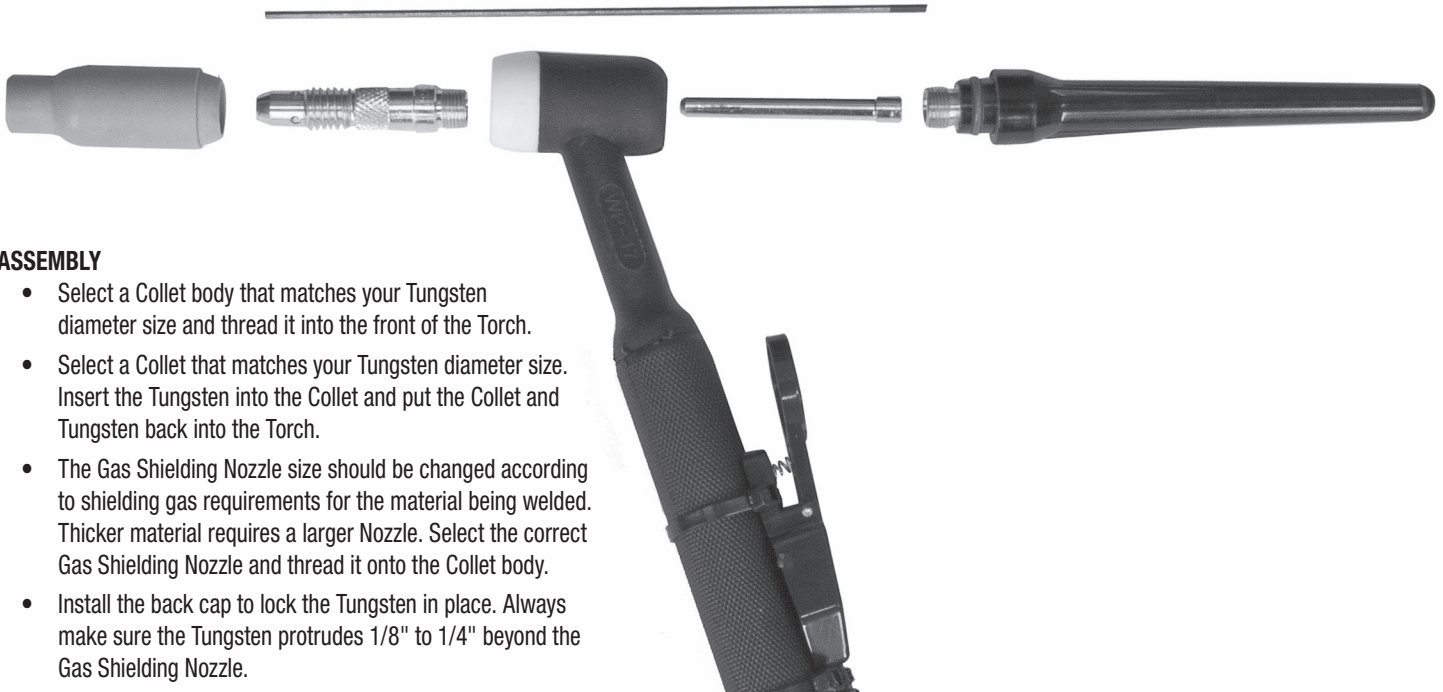

ASSEMBLY

- Select a Collet body that matches your Tungsten diameter size and thread it into the front of the Torch.
- Select a Collet that matches your Tungsten diameter size. Insert the Tungsten into the Collet and put the Collet and Tungsten back into the Torch.
- The Gas Shielding Nozzle size should be changed according to shielding gas requirements for the material being welded. Thicker material requires a larger Nozzle. Select the correct Gas Shielding Nozzle and thread it onto the Collet body.
- Install the back cap to lock the Tungsten in place. Always make sure the Tungsten protrudes 1/8" to 1/4" beyond the Gas Shielding Nozzle.

DISASSEMBLY

- Make sure the welder is turned OFF and unplugged.
- Remove the Back Cap from the Torch.
- If there is a Tungsten installed in the Torch pull it out of the front of the Torch.
- Slide the Collet out of the Torch.
- Unscrew and remove the Gas Shielding Nozzle.
- Unscrew and remove the Collet body.

SHARPENING THE TUNGSTEN

To avoid contamination of the Tungsten and ultimately the weld, it is imperative to have a dedicated grinding wheel used for Tungsten grinding only. A fine grit standard 6" synthetic stone grinding wheel on a bench top grinder is sufficient or specifically designed Tungsten Grinders are available.

- Shut off the welder.
- Make sure the Tungsten and Torch are sufficiently cooled for handling then loosen and remove the Back Cap then the Collet and remove the Tungsten from the FRONT of the Torch only. (Removing from the rear will damage the Collet) (FIG 8).
- If the Tungsten is used and the end is contaminated, use pliers or a suitable tool to grip the Tungsten above the contaminated section and snap off the end of the Tungsten.
- Holding the Tungsten tangent to the surface of the grinding wheel, rotate the Tungsten while exerting light pressure until a suitable point is formed (FIG 9). The ideal tip will have the length of the conical portion of the sharpened area at 2-1/2 times the Tungsten rod diameter (FIG 10).
- Replace the Tungsten in the Collet with the tip extending 1/8"-1/4" beyond the Gas Shielding Nozzle, then re-tighten the Back Cap (FIG 11).

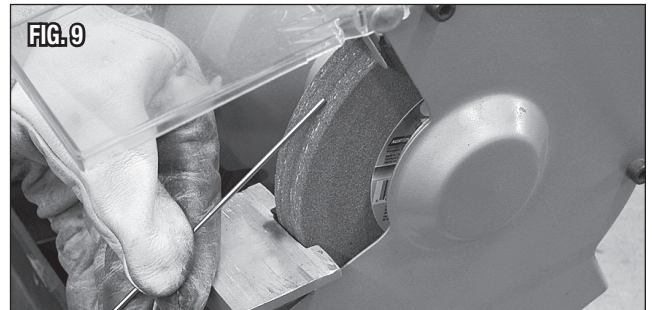

FIG. 9

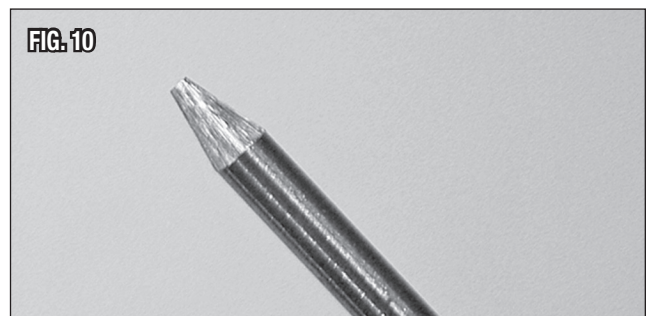

FIG. 10

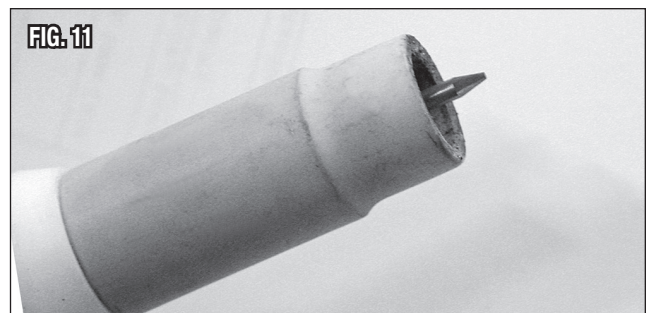

FIG. 11

WELDER CARE & MAINTENANCE

⚠ WARNING ELECTRIC SHOCK CAN CAUSE INJURY OR DEATH!

- Improper use of an electric Welder can cause electric shock, injury and death! Read all precautions described in the Welder Manual to reduce the possibility of electric shock.
- Disconnect Welder from power supply before assembly, disassembly or maintenance of the torch, contact tip and when installing or removing nozzles.
- Always wear dry, protective clothing and leather welding gloves and insulated footwear. Use suitable clothing made from durable flame-resistant material to protect your skin.
- If other persons or pets are in the area of welding, use welding screens to protect bystanders from sparks.
- Always operate the Welder in a clean, dry, well ventilated area. Do not operate the Welder in humid, wet, rainy or poorly ventilated areas.
- The electrode and work (or ground) circuits are electrically “hot” when the Welder is on. Do not allow these “hot” parts to come in contact with your bare skin or wet clothing.
- Separate yourself from the welding circuit by using insulating mats to prevent contact from the work surface.
- Be sure that the work piece is properly supported and grounded prior to beginning an electric welding operation.
- Always attach the ground clamp to the piece to be welded and as close to the weld area as possible. This will give the least resistance and best weld.

- Constantly inspect the torch tip for excessive erosion, molten metal accumulation burning. If damaged, it must be replaced.
- Before each use, inspect ALL electrical connections, cables, supply line, torch, air supply, housing and controls for damage. If any damage or wear is noted, **DO NOT USE THE UNIT.**
- If the welder requires service, it should be performed by a certified repair facility using only authorized replacement parts to maintain full safety and performance integrity of the welder.
- DO NOT attempt to make repairs or replace parts unless you are a certified and qualified technician.
- Eastwood disclaims all warranties and liabilities when repairs or the replacement of parts is attempted by a non-certified and qualified technician.
- DO NOT open the welding machine unless you are a properly trained technician.
- Always store the unit in a safe, clean and dry environment.

TORCH MAINTENANCE

⚠ WARNING ELECTRIC SHOCK CAN CAUSE INJURY OR DEATH!

- Improper use of an electric Welder can cause electric shock, injury and death! Read all precautions described in the Welder Manual to reduce the possibility of electric shock.
- Disconnect Welder from power supply before assembly, disassembly or maintenance of the torch, contact tip and when installing or removing nozzles.
- Always wear dry, protective clothing and leather welding gloves and insulated footwear. Use suitable clothing made from durable flame-resistant material to protect your skin.
- If other persons or pets are in the area of welding, use welding screens to protect bystanders from sparks.
- Always operate the Welder in a clean, dry, well ventilated area. Do not operate the Welder in humid, wet, rainy or poorly ventilated areas.
- The electrode and work (or ground) circuits are electrically “hot” when the Welder is on. Do not allow these “hot” parts to come in contact with your bare skin or wet clothing.
- Separate yourself from the welding circuit by using insulating mats to prevent contact from the work surface.
- Be sure that the work piece is properly supported and grounded prior to beginning an electric welding operation.
- Always attach the ground clamp to the piece to be welded and as close to the weld area as possible. This will give the least resistance and best weld.

- The Eastwood TIG 200 Digital has a number of consumable parts that will need to be replaced over time. If wear or slag build up is noticed on any of the torch components, replace them immediately to avoid damage to the torch. Worn components will also contribute to poor performance. See the torch components exploded view (**FIG 8**) for a reference of all of the components and the assembly order.

TIG TROUBLESHOOTING

Arc is Triggered but Will not Start	Incomplete Circuit	Check Ground connection. Make sure that the ground is on a freshly cleaned surface and close to the welding area. It is suggested to weld towards the ground connection.
	Incorrect Tungsten	Consult chart for proper Tungsten for the base metal being welded. In most cases Thoriated will be used for all steels.
	No Shielding Gas	Make sure the shielding gas cylinder is turned all the way open and set at the correct flow rate.
Arc Wanders and It is Hard to Concentrate Heat in a Specific Area	Poorly Prepped Tungsten	Follow guidelines for prepping Tungsten.
	Poor Gas Flow	Adjust the flow rate of the shielding gas (refer to settings chart). Check for loose fittings where gas could be leaking.
	Contaminated Tungsten	Remove Tungsten from Torch and break off contaminated section and resharpen.
	Incorrect Arc Length	Make sure the Tungsten is held 1/8 to 1/4 inch off the work piece.
	Incomplete Circuit	Check Ground connection. Make sure that the ground is on a freshly cleaned surface and close to the welding area. It is suggested to weld towards the ground connection.
	Contaminated Base Metal	Clean base metal making sure to remove any oil, debris, coatings, or moisture. If base metal is aluminum make sure all of the oxide is removed using either a dedicated stainless brush or flap wheel.
Porosity in Weld Bead	Poor Gas Flow	Adjust the flow rate of the shielding gas. Check for loose fittings where gas could be leaking.
	Contaminated Filler Material	Clean filler metal making sure to remove any oil, debris, or moisture.
	Contaminated Base Metal	Clean base metal making sure to remove any oil, debris, coatings, or moisture.
	Poor Shielding	Make sure to be in an area with no wind and with any fans turned off. Wind or fans will blow the shielding gas away from the weld causing porosity.
	Incorrect Tungsten Exposure	Adjust the Tungsten so that 1/8" to 1/4" protrudes from the Collet.
Contamination in Weld Bead	Contaminated Tungsten	Remove Tungsten from Torch and break off contaminated section and resharpen.
	Contaminated Filler Metal	Clean filler metal making sure to remove any oil, debris, or moisture.
	Contaminated Base Metal	Clean base metal making sure to remove any oil, debris, coatings, or moisture. If base metal is aluminum make sure all of the oxide is removed using either a dedicated stainless brush or flap wheel.
Melting Tungsten	Poor Gas Flow	Adjust the flow rate of the shielding gas. Check for loose fittings where gas could be leaking.
	Wrong Size Tungsten	Increase Tungsten diameter. Refer to chart for proper sizing.
	Incorrect Gas Shielding	Only use 100% Argon when TIG Welding.

TIG TROUBLESHOOTING

Poor Penetration	Amperage Too Low	Voltage setting is too low for material/thickness. Increase as needed.
Tungsten Contaminated	Contact of Tungsten with Base Metal	Keep Tungsten 1/8" to 1/4" from the base metal. If Tungsten comes in contact break off end and resharpen immediately.
Poor Weld Appearance	Incorrect Positioning	The angle between the filler metal and the Torch must be less than 90 degrees otherwise the filler metal will prematurely melt and glob off causing poor weld appearance.
Crater in the End of the Weld Bead	Insufficient Shielding	Keep the Torch on the base metal while the post flow shielding gas flows to protect and cool the metal and Tungsten.
	Not Enough Filler Material	Reduce current and add more filler at end of weld. It may also be beneficial to back step to ensure no crater will form.
Weld Bead is Cracking	Too Much Heat in Material	Reduce heat and allow more time between passes.
	Base Metal is Absorbing Too Much Heat	Preheat base metal (consult welding codes for requirements).
	Incorrect Filler Wire	Use appropriate filler wire type and diameter for the joint being welded.
Material is Warping	Insufficient Clamping	Clamp work piece tightly and weld while clamps are in place.
	Insufficient Tack Welds	Add more tack welds until rigidity and stiffness is developed.
	Too Much Heat in Material	To reduce heat it is best to spread the welding out around the area. This can be done by using stitch welding techniques, alternating sides, and/or taking your time and allowing the pieces to cool between passes.

STICK (ARC) WELDING

⚠ DANGER ELECTRIC SHOCK CAN CAUSE INJURY OR DEATH!

- Improper use of an electric Welder can cause electric shock, injury and death! Read all precautions described in the Welder Manual to reduce the possibility of electric shock.
- Disconnect Welder from power supply before assembly, disassembly or maintenance of the torch, contact tip and when installing or removing nozzles.
- Always wear dry, protective clothing and leather welding gloves and insulated footwear. Use suitable clothing made from durable flame-resistant material to protect your skin.
- If other persons or pets are in the area of welding, use welding screens to protect bystanders from sparks.
- Always operate the Welder in a clean, dry, well ventilated area. Do not operate the Welder in humid, wet, rainy or poorly ventilated areas.
- The electrode and work (or ground) circuits are electrically “hot” when the Welder is on. Do not allow these “hot” parts to come in contact with your bare skin or wet clothing.
- Separate yourself from the welding circuit by using insulating mats to prevent contact from the work surface.
- Be sure that the work piece is properly supported and grounded prior to beginning an electric welding operation.
- Always attach the ground clamp to the piece to be welded and as close to the weld area as possible. This will give the least resistance and best weld.

⚠ DANGER WELDING SPARKS CAN CAUSE FIRE OR EXPLOSION!

- Electric welding produces sparks which can be discharged considerable distances at high velocity igniting flammable or exploding vapors and materials.
 - DO NOT operate electric arc Welder in areas where flammable or explosive vapors are present.
 - DO NOT use near combustible surfaces. Remove all flammable items from the work area where welding sparks can reach (minimum of 35 feet).
- Always keep a fire extinguisher nearby while welding.
- Use welding blankets to protect painted and or flammable surfaces; rubber weather-stripping, dash boards, engines, etc.
- Ensure power supply has properly rated wiring to handle power usage.

⚠ WARNING ELECTROMAGNETIC FIELDS CAN BE A HEALTH HAZARD!

- The electromagnetic field that is generated during arc welding may interfere with various electrical and electronic devices such as cardiac pacemakers. Anyone using such devices should consult with their physician prior to performing any electric welding operations.
- Exposure to electromagnetic fields while welding may have other health effects which are not known.

⚠ WARNING ARC RAYS CAN INJURE EYES AND BURN!

- Arc rays produce intense ultraviolet radiation which can burn exposed skin and cause eye damage. Use a shield with the proper filter (a minimum of #11) to protect your eyes from sparks and the rays of the arc when welding or when observing open arc welding (see ANSI Z49.1 and Z87.1 for safety standards).
- Use suitable clothing made from durable flame-resistant material to protect your skin.
- If other persons or pets are in the area of welding, use welding screens to protect bystanders from sparks and arc rays.

⚠ WARNING FUMES AND WELDING GASES CAN BE HEALTH HAZARD!

- Fumes and gasses released during welding are hazardous. Do not breathe fumes that are produced by the welding operation.
- Prolonged inhalation of welding fumes above safety exposure limits can injure the lungs and other organs.
- Use enough ventilation and/or exhaust at the arc to keep fumes and gases from your breathing area.
- Use an OSHA approved respirator when welding in confined spaces or where there is inadequate ventilation.
- Never weld coated materials including but not limited to: cadmium plated, galvanized, lead based paints.

⚠ CAUTION HOT METAL AND TOOLS WILL BURN!

- Electric welding heats metal and tools to temperatures that will cause severe burns!
- Use protective, heat resistant gloves and clothing when using Eastwood or any other welding equipment. Never touch welded work surface, torch tip or nozzle until they have completely cooled.

STICK (ARC) WELDING

SETTING PARAMETERS

Choose the Stick mode, adjust slope-up time (arc force) and peak current.

Welding Current Settings Table - Flat Welding					
Electrode (mm)	2.6	3.2	4.0	4.5	5.0
Limelite Electrode	50 ~ 85	80 ~ 130	120 ~ 180	145 ~ 200	170 ~ 205
Titanium/Calcium Electrode	50 ~ 100	90 ~ 130	140 ~ 180	160 ~ 210	190 ~ 150
Low Hydrogen Electrode	55 ~ 85	100 ~ 140	140 ~ 190	-	190 ~ 250

Welding Current Settings Table - Vertical Welding					
Electrode (mm)	2.6	3.2	4.0	4.5	5.0
Limelite Electrode	40 ~ 75	60 ~ 110	100 ~ 150	120 ~ 180	130 ~ 200
Titanium/Calcium Electrode	50 ~ 90	80 ~ 130	110 ~ 170	125 ~ 190	140 ~ 210
Low Hydrogen Electrode	50 ~ 80	90 ~ 130	120 ~ 180	-	160 ~ 210

STICK (ARC) WELDING

- Plug the power cord into a properly grounded, 240 Volt AC 50/60Hz. 50 Amp circuit.
- Move the Welding Modes Switch to the "ARC" position (**FIG 1**).
- Make sure the Electrode or "Stick" is not making contact with the grounded workpiece.
- Move the Power Switch on the upper rear of the Welder to the "ON" position.
- While wearing a properly functioning Auto Darkening Welding Helmet, lightly drag the tip of the Welding Rod along the workpiece surface to start an arc.
- Feed the Welding Rod into the workpiece joint at a 15° angle.
- Lift rod from workpiece when weld bead is completed.
- Turn off Welder power switch.
- Set the Electrode or "Stick" Holder on a safe, non-flammable, surface.

STICK WELD CONNECTION WITH OPTIONAL 20517 EASTWOOD STICK WELD TORCH

- Disconnect and remove the TIG Torch/Foot Pedal Connections if in place.
- Insert the BLACK Stick Weld Connector into the BLACK Stick Weld Connection located at the far left of the Front Panel. With the Key of the Connector at the 12:00 position, push in and rotate 180° Clockwise to lock the connector in.
- Insert the RED Ground Connector into the RED Ground Connection located at the far right of the Front Panel. With the Key of the Connector at the 12:00 position, push in and rotate 180° Clockwise to lock the connector in. **NOTE:** The above connections are the standard default for Stick Welding.
- If your material or rod preference dictates it, the Stick Weld and Ground Connections may safely be reversed.

STICK (ARC) WELDING TROUBLESHOOTING

Electrode Sticking	Arc Too Short	While welding, keep the ignited end of the electrode further from the weld joint.
	Current Too Low	Adjust the current on the front of the Welder to a higher current setting.
Holes in Weld Bead (Porosity)	Arc Too Long	While welding, keep the ignited end of the electrode closer to the weld joint.
	Moisture in Electrode	Replace electrode with a new one.
Excessive Spatter	Arc Too Long	While welding, keep the ignited end of the electrode closer to the weld joint.
	Current Too High	Adjust the current on the front of the Welder to a lower current setting.
Poor Penetration	Poor Joint Preparation	Clean the weld joint of any dirt, grease, paint or other possible contaminants. If the pieces being Welder are of a heavy gauge it may be necessary to bevel the edges of the pieces.
	Current Too Low	Adjust the current on the front of the Welder to a higher current setting.
	Travel Speed Too Fast	Slow down the travel speed of the electrode while welding.
Overload Light On	Duty Cycle Exceeded	Allow the Welder to cool for a minimum of 15 minutes before attempting to use again.

TYPES OF WELD JOINTS

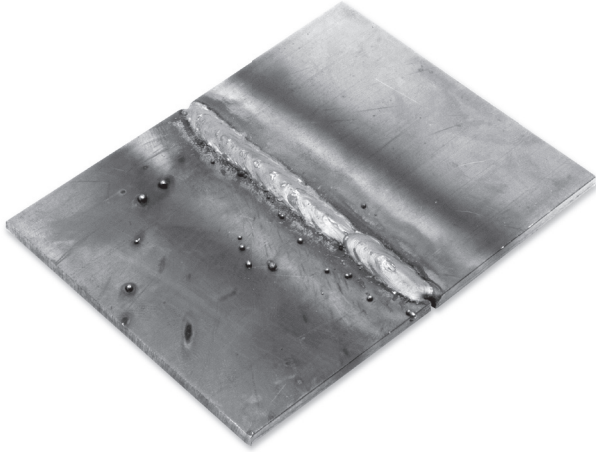

BUTT WELD is a joint between two pieces that are laying in the same direction.

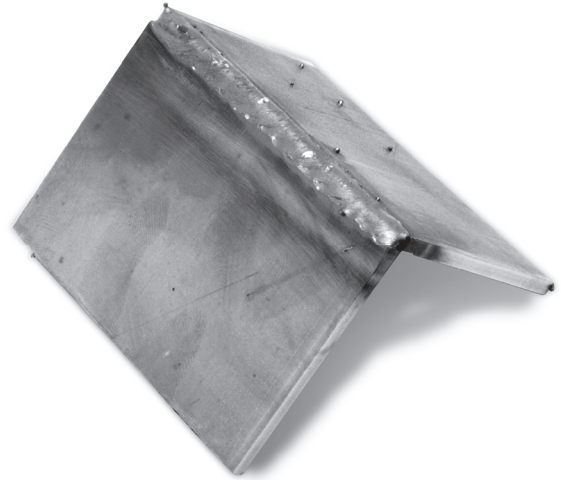

CORNER WELD is a joint between two pieces that meet at or near perpendicular at their edges.



EDGE WELD is a joint between two pieces where the edges are being joined.

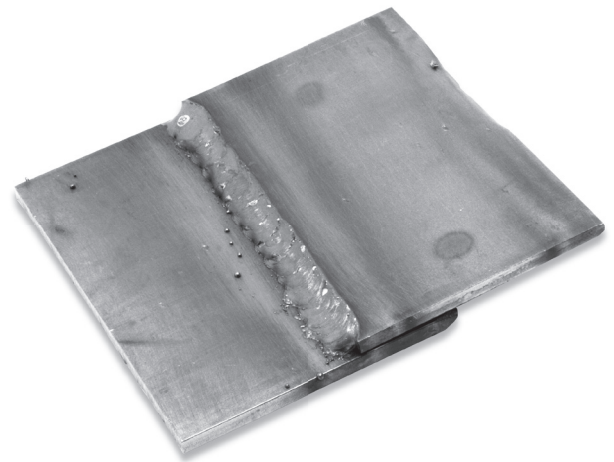

LAP WELD is a joint between two overlapping pieces.

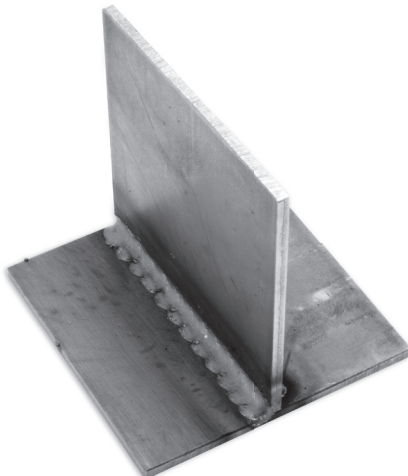

TEE WELD is a joint between two pieces where one is perpendicular to the other.



PLUG WELD is a joint which joins two overlapping pieces by filling in a hole punched in the top piece.

AVAILABLE ITEMS

CONSUMABLE ITEMS

- #13483 Collet Body (1.6mm; 1/16")
- #13484 Collet Body (2.4mm; 3/32")
- #12822 Collet (1.6mm; 1/16")
- #12824 Collet (2.4mm; 3/32")
- #12825 Long Back Cap
- #12819 Gas Nozzle (9.8mm; 3/8")
- #12821 Gas Nozzle (11.2mm; 1/2")
- #13953 TIG Accessory Kit
- #20284 Gas Lens Kit

TIG WIRE & TUNGSTEN

- #12253 ER70S-2 Steel TIG Wire 1/16-36"
- #12254 ER70S-2 Steel TIG Wire 3/32-36"
- #12375 4043 Aluminum TIG Wire 1/16-36"
- #12376 4043 Aluminum TIG Wire 3/32-36"
- #12463 308L Stainless TIG Wire 1/16-36"
- #12464 308L Stainless TIG Wire 3/32-36"
- #20176 E3 Purple Tungsten 1/16-7" 2pc
- #20177 E3 Purple Tungsten 3/32-7" 2pc. **NOTE:** E3 Purple Tungsten is universal and can be used on steel, aluminum, and stainless steel.

OPTIONAL WELDING ITEMS AND ACCESSORIES

- #12236 Welding Cart
- #11616 Deluxe MIG / TIG / Plasma Welding Cart
- #13203 Auto Darken Welding Helmet
- #13212 Large View Auto Darken Welding Helmet
- #12957 Welding Helmet Bag
- #12762 L/XL/XXL Welding Jacket
- #12590 Welding Gloves Large
- #12589 Welding Gloves Medium
- #20639 10' Long Ground Cable Extension
- #19055A Flap Disc 60 Grit 4.5" Diameter 7/8" Hole
- #19079S Stainless Steel Brush
- #51139 Copper 3 x 3 Welders Helper Set
- #50739 Master Welder's Helper Panel Holding Kit
- #19001 Welding Rod 1/16" Diameter, 3 lbs.
- #12238 Welding Gas Regulator
- #20277 Eastwood Welding Flow Meter
- #20517 200A Electrode Holder
- #21260 TIG Torch – Standard
- #21259 Flex-Head TIG Torch

If you have any questions about the use of this product, please contact

The Eastwood Technical Assistance Service Department: 800.544.5118 >> email: techelp@eastwood.com

PDF version of this manual is available online >> eastwood.com/20589manual

The Eastwood Company 263 Shoemaker Road, Pottstown, PA 19464, USA

US and Canada: 800.343.9353 Outside US: 610.718.8335

Fax: 610.323.6268 eastwood.com