



DO THE JOB RIGHT.®

Item #21180

MP250i WELDER

INSTRUCTIONS



The **EASTWOOD MP250i WELDER** provides the ability to MIG, TIG or ARC (Stick) weld all from a single, high-powered, self-contained unit. Inverter Technology provides the capability of welding thin or heavy gauge steel with precision and ease. For additional versatility and aluminum welding capability, add the optionally available Eastwood # 20172 Spool Gun.

READ AND UNDERSTAND ALL INSTRUCTIONS AND PRECAUTIONS BEFORE PROCEEDING.

This unit emits a powerful high voltage and extreme heat which can cause severe burns, dismemberment, electrical shock and death. Eastwood shall not be held liable for consequences due to deliberate or unintentional misuse of this product.

STATEMENT OF LIMITED WARRANTY

The Eastwood Company (hereinafter "Eastwood") warrants to the end user (purchaser) of all new welding and cutting equipment (collectively called the "products") that it will be free of defects in workmanship and material. This warranty is void if the equipment has been subjected to improper installation, improper care or abnormal operations.

WARRANTY PERIOD:

All warranty periods begin on the date of purchase from Eastwood. Warranty Periods are listed below, along with the products covered during those warranty periods:

3 Year Warranty on Material, Workmanship, and Defects:

- Eastwood MP250i Welder Items not covered under this warranty: Consumables, Collets, Collet Bodies, Electrodes, Nozzles, Ground Clamp and Cable. All other components are covered by the warranty and will be repaired or replaced at the discretion of Eastwood.

2 Years:

- All Welding Helmets.

CONDITIONS OF WARRANTY TO OBTAIN WARRANTY COVERAGE:

Purchaser must first contact Eastwood at 1-800-345-1178 for an RMA# before Eastwood will accept any Welder returns. Final determination of warranty on welding and cutting equipment will be made by Eastwood.

WARRANTY REPAIR:

If Eastwood confirms the existence of a defect covered under this warranty plan, Eastwood will determine whether repair or replacement is the most suitable option to rectify the defect. At Eastwood's request, the purchaser must return, to Eastwood, any products claimed defective under Eastwood's warranty.

FREIGHT COSTS:

The purchaser is responsible for shipment to and from Eastwood.

WARRANTY LIMITATIONS:

EASTWOOD WILL NOT ACCEPT RESPONSIBILITY OR LIABILITY FOR REPAIRS UNLESS MADE BY EASTWOOD. EASTWOOD'S LIABILITY UNDER THIS WARRANTY SHALL NOT EXCEED THE COST OF CORRECTING THE DEFECT OF THE EASTWOOD PRODUCT. EASTWOOD WILL NOT BE LIABLE FOR INCIDENTAL OR CONSEQUENTIAL DAMAGES (SUCH AS LOSS OF BUSINESS, ETC.) CAUSED BY THE DEFECT OR THE TIME INVOLVED TO CORRECT THE DEFECT. THIS WRITTEN WARRANTY IS THE ONLY EXPRESS WARRANTY PROVIDED BY EASTWOOD WITH RESPECT TO ITS PRODUCTS. WARRANTIES IMPLIED BY LAW SUCH AS THE WARRANTY OF MERCHANTABILITY ARE LIMITED TO THE DURATION OF THIS LIMITED WARRANTY FOR THE EQUIPMENT INVOLVED. THIS WARRANTY GIVES THE PURCHASER SPECIFIC LEGAL RIGHTS.

THE PURCHASER MAY ALSO HAVE OTHER RIGHTS WHICH VARY FROM STATE TO STATE.

CONTENTS

- | | | |
|---|---|---|
| (1) MP250i Welder | (1) MIG Torch with 14.8' [4.5m] Cable, 0.030" Tip Installed | (1) Short Back Cap (Installed) |
| (1) Front Caster Assembly | (2) Spare Contact Tips (0.030" & 0.035") | (1) Long Back Cap |
| (1) Rear Wheel/Gas Cylinder Tray Assembly | (1) Contact Tip Wrench | (1) Collet Body, 3/32" [2.4mm] (Installed) |
| (2) Gas Cylinder Brackets | (1) 2mm Hex Key | (1) Collet, 1/16" [1.6mm] |
| (2) Gas Cylinder Chains | (1) Electrode Holder with 14.8' [4.5m] Cable | (1) Collet, 1/8" [3.2mm] |
| (18) M5 x 12mm Screws | (1) TIG Torch (Tweco Style) with 14.8' [4.5m] cable and 17.8' [5.5m] Gas Line | (1) 1/16" x 6" [2.0mm x 150mm] Tungsten (Red) |
| (3) M5 Nuts | (1) #5 Gas Nozzle (5/16") (Installed) | (1) Adapter Cord, 24" [0.6m] |
| (6) M5 Flat Washers | (1) #6 Gas Nozzle (3/8") | (1) Welding Mask |
| (3) M5 Lockwashers | (1) #7 Gas Nozzle (7/16") | (1) Hammer/Brush |
| (1) Shielding Gas Hose, 4.6' [1.4m] | | (1) Instruction Manual |
| (1) Ground Clamp with 14.8' [4.5m] Cable | | |

SPECIFICATIONS

POWER SUPPLY

Power Voltage (V)	1 phase 240V±10%	1 phase 120V±10%
Frequency (Hz)	50/60	
No Load Voltage (V)	61	
Rated Input Current (Amps)	MIG = 47.3 TIG = 35.7 Arc = 53.5	MIG = 42 TIG = 31.2 Arc = 51.1
Output Current Adjustment (Amps)	MIG = 50-250 TIG = 15-250 Arc = 25-250	MIG = 50-140 TIG = 15-140 Arc = 25-140
Output Voltage (V)	MIG = 16.5-26.5 TIG = 10.6-20 Arc = 21-30	MIG = 16.5-21 TIG = 10.6-15.6 Arc = 21-25.6
Duty Cycle (%)	60% @ 250 Amps	
Power Factor	0.73	
Efficiency (%)	80	
Wire Feed Speed (ft/min)	78-629	
Post Flow Time (seconds)	1.0 ± 0.5	
Weight	96 lbs. [43.6kg]	
Dimensions	36" x 21" x 31" [900mm x 765mm x 765mm]	

MIG WELDING WIRE

	Solid	Stainless	Flux Core
Wire Type and Diameter	0.030-0.045" [0.8-1.2mm]	0.030-0.045" [0.8-1.2mm]	0.030-0.045" [0.8-1.2mm]

SPOOL GUN WELDING WIRE

	4043 Aluminum
Wire Type and Diameter	0.030-0.035" [0.8-0.9mm]

ARC WELDING RODS

Type	E6010	E6011	E6013	E7014	E7018
Diameter	1/16", 3/32", 1/8", 7/32"	1/16", 3/32", 1/8", 7/32"	1/16", 3/32", 1/8", 7/32"	1/16", 3/32", 1/8", 7/32"	1/16", 3/32", 1/8", 7/32"
Polarity	DCEN	DCEN	DCEN, DCEP	DCEN, DCEP	DCEP

DUTY CYCLE

The rated Duty Cycle refers to the amount of welding that can be done within an amount of time. The Eastwood MP250i has a Duty Cycle of 60% at 250 Amps. It is easiest to look at your welding time in blocks of 10 Minutes and the Duty Cycle being a percentage of that 10 Minutes. If welding at 250 Amps with a 60% Duty Cycle, within a 10 Minute block of time you can weld for 6 Minutes with 4 Minutes of cooling for the Welder.

If the Duty Cycle is exceeded, the Welder will automatically shut off, however the fan will continue running to cool the internal components. When a safe temperature has been reached, the Welder will automatically switch the Welder output back on. To increase the Duty Cycle you can turn down the Voltage Output control.

SAFETY INFORMATION

IMPORTANT NOTE:

These instructions are intended only to provide the user with some familiarity of the Eastwood MP250i. Electric Welding is a highly complex procedure with many variables. If you have no prior experience with Electric Welding, it is extremely important to seek the advice of someone experienced in Electric Welding for instruction, enroll in a local technical school welding course or study a comprehensive how-to DVD and obtain a good quality reference book on Electric Welding as there is a moderate learning curve necessary before achieving proficiency in Welding different metals such as steel, stainless steel and aluminum. It is also strongly recommended that the user adhere to the American Welding Society guidelines, codes and applications prior to producing welds where safety is affected.

Welding can be dangerous to you and other persons in the work area. Read and understand this instruction manual before using your Eastwood welding machine. Injury or death can occur if safe welding practices are not followed. Safety information is set forth below and throughout this manual. Save these instructions for future reference.

To learn more about welding safety, read OSHA Title 29 CFR 1910, available at www.osha.gov; ANSI Z49.1, "Safety in Welding, Cutting and Allied Processes," available at www.aws.org; and the consumable manufacturer's Safety Data Sheets.

The following explanations are displayed in this manual, on the labeling, and on all other information provided with this product:

DANGER

DANGER indicates a hazardous situation which, if not avoided, will result in death or serious injury.

WARNING

WARNING indicates a hazardous situation which, if not avoided, could result in death or serious injury.

CAUTION

CAUTION used with the safety alert symbol, indicates a hazardous situation which, if not avoided, could result in minor or moderate injury.

NOTICE

NOTICE is used to address practices not related to personal injury.



DANGER **ELECTRIC SHOCK CAN CAUSE INJURY OR DEATH!**

- Improper use of an electric Welder can cause electric shock, injury and death! Read all precautions described in the Welder Manual to reduce the possibility of electric shock.
- Disconnect Welder from power supply before assembly, disassembly or maintenance of the torch, contact tip and when installing or removing nozzles.
- Always wear dry, protective clothing and leather welding gloves and insulated footwear. Use suitable clothing made from durable flame-resistant material to protect your skin.
- If other persons or pets are in the area of welding, use welding screens to protect bystanders from sparks and ARC rays.
- Always operate the Welder in a clean, dry, well ventilated area. Do not operate the Welder in humid, wet, rainy or poorly ventilated areas.
- The electrode and work (or ground) circuits are electrically "hot" when the Welder is on. Do not allow these "hot" parts to come in contact with your bare skin or wet clothing.
- Separate yourself from the welding circuit by using insulating mats to prevent contact from the work surface.
- Be sure that the work piece is properly supported and grounded prior to beginning an electric welding operation.
- Always attach the Ground Clamp to the piece to be welded and as close to the weld area as possible. This will give the least resistance and best weld.



DANGER **WELDING SPARKS CAN CAUSE FIRE OR EXPLOSION!**

- Electric welding produces sparks which can be discharged considerable distances at high velocity igniting flammable or exploding vapors and materials.
DO NOT operate electric arc Welder in areas where flammable or explosive vapors are present.
DO NOT use near combustible surfaces. Remove all flammable items from the work area where welding sparks can reach (min. of 35 feet).
- Always keep a fire extinguisher nearby while welding.
- Use welding blankets to protect painted and or flammable surfaces; rubber weather-stripping, dash boards, engines, etc.
- Ensure power supply has properly rated wiring to handle power usage.

SAFETY INFORMATION



⚠ WARNING ELECTROMAGNETIC FIELDS CAN BE A HEALTH HAZARD!

- The electromagnetic field that is generated during arc welding may interfere with various electrical and electronic devices such as cardiac pacemakers. Anyone using such devices should consult with their physician prior to performing any electric welding operations.
- Exposure to electromagnetic fields while welding may have other health effects which are not known.



⚠ WARNING ARC RAYS CAN INJURE EYES AND BURN!

- Arc rays produce intense ultraviolet radiation which can burn exposed skin and cause eye damage. Use a shield with the proper filter (a minimum of #11) to protect your eyes from sparks and the rays of the arc when welding or when observing open arc welding (see ANSI Z49.1 and Z87.1 for safety standards).
- Use suitable clothing made from durable flame-resistant material to protect your skin.
- If other persons or pets are in the area of welding, use welding screens to protect bystanders from sparks and arc rays.



⚠ WARNING FUMES AND WELDING GASES CAN BE A HEALTH HAZARD!

- Fumes and gasses released during welding are hazardous. Do not breathe fumes that are produced by the welding operation.
- Prolonged inhalation of welding fumes above safety exposure limits can injure the lungs and other organs.
- Use enough ventilation and/or exhaust at the arc to keep fumes and gases from your breathing area.
- Use an OSHA approved respirator when welding in confined spaces or where there is inadequate ventilation.
- Never weld coated materials including, but not limited to: cadmium plated, galvanized, lead based paints.



⚠ WARNING BUILDUP OF GAS CAN INJURE OR KILL!

- Shut off gas supply when not in use.
- Ensure adequate ventilation
- Do not weld in confined areas.
- Always turn your face away from valve outlet when opening cylinder valve.



⚠ WARNING CYLINDERS CAN EXPLODE IF DAMAGED!

Shielding gas cylinders contain gas under high pressure. If damaged, a cylinder can explode. As gas cylinders are a normal component of the welding process, use extra care to handle them carefully.

- Protect compressed gas cylinders from excessive heat, mechanical shocks, physical damage, slag, open flames, sparks and arcs. Keep away from any welding or other electrical circuits.
- Install cylinders in an upright position by securing to a specifically designed rack, cart or stationary support to prevent falling or tipping over.
- Never weld on a pressurized cylinder or explosion will occur.
- Use only correct shielding gas cylinders, regulators, hoses and fittings designed for the specific application; maintain them and all related components in good condition.
- Keep protective cap in place over valve except when cylinder is in use.
- Use proper equipment, procedures and have adequate help when moving or lifting cylinders.

SAFETY INFORMATION



⚠ CAUTION HOT METAL AND TOOLS WILL BURN!!

- Electric welding heats metal and tools to temperatures that will cause severe burns!
- Use protective, heat resistant gloves and clothing when using Eastwood or any other welding equipment. Never touch welded work surface, torch tip or nozzle until they have completely cooled.



⚠ CAUTION FLYING METAL CHIPS CAN CAUSE INJURY!

- Grinding and sanding will eject metal chips, dust, debris and sparks at high velocity. To prevent eye injury wear approved safety glasses.
- Wear an OSHA-approved respirator when grinding or sanding.
- Read all manuals included with specific grinders, sanders or other power tools used before and after the welding process. Be aware of all power tool safety warnings.



⚠ NOTICE FIRST AID

- If exposed to excessive fumes move to an area with fresh air. Follow safety information on manufacturer's Safety Data Sheet.
- For other injuries follow basic first aid techniques and call a physician or emergency medical personnel.

CONNECTING THE WELDER TO A POWER SOURCE

The Eastwood MP250i Welder has dual current capability and requires a dedicated 120 VAC, 20 Amp or a 240 VAC, 50 Amp, 60HZ grounded outlet protected by a circuit breaker. The plug installed on the Welder is a NEMA 6-50P and should be used with a NEMA 6-50R receptacle. If using an extension cord, use a minimum 6 AWG cord for up to 25 feet.

ASSEMBLY

FRONT WHEELS

- Pull Welder from packaging, lift front end and support it securely.
- Using three M5 Nuts and Washers, locate over studs and attach the front Caster Assembly and Front Caster Spacer to the underside of the cabinet (**FIG 1**).

REAR WHEELS

- Lift and support rear end of Welder.
- Using (4) M5 x 12mm screws on rear and three M5 x 20mm Screws and Washers at the underside, attach the Rear Wheel/Tray Assembly to the underside and rear of the cabinet (**FIGS 2 & 3**).

TANK SUPPORTS

- With flanges facing downward, attach the two Tank Supports to the rear of the cabinet with three M5 x 12mm screws each (**FIG 4**).

TANK CHAINS

- Hook ends of Tank Chains into the slots on the outer corners of the Tank Supports (**FIG 4**).

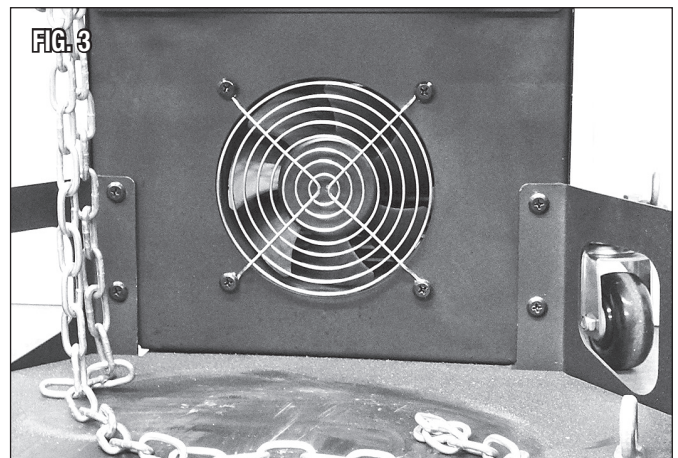
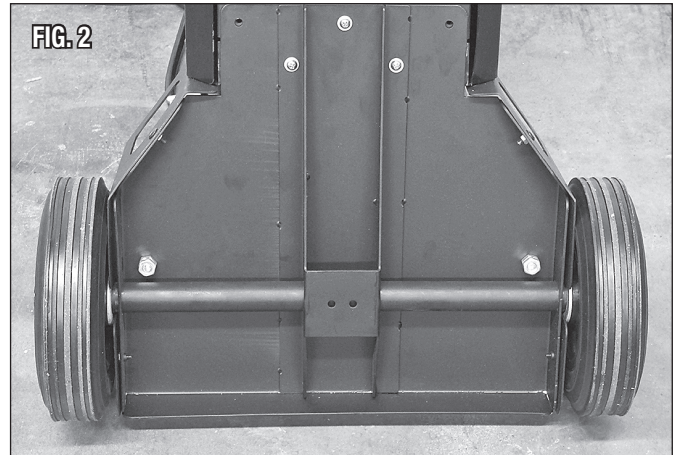

CONTROL AND DISPLAY PANEL

The Eastwood MP250i Front Panel is arranged with 8 major groups of Function Controls and LED Indicators. They are as follows:

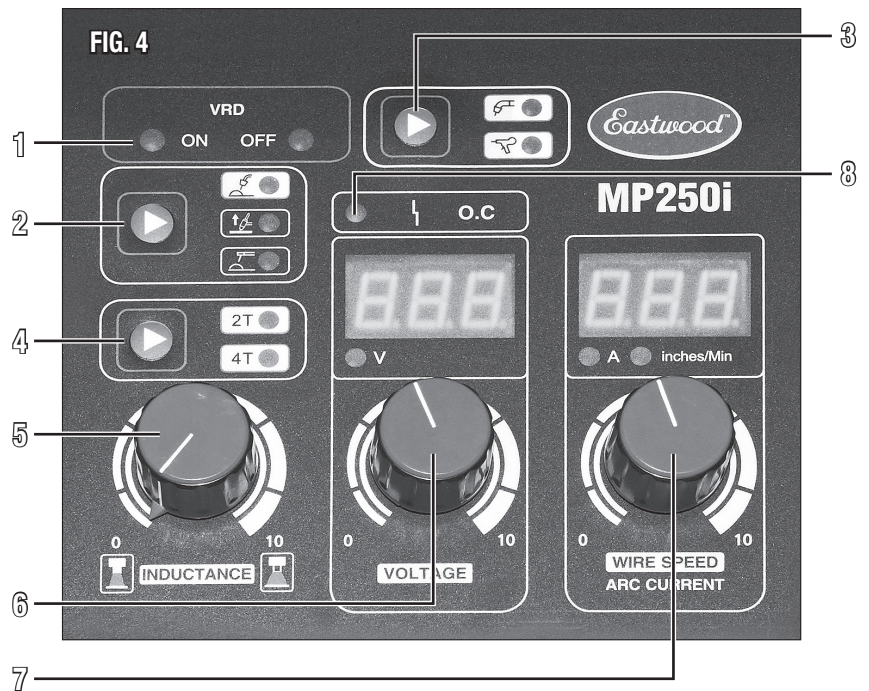

1. **VRD Switch:** VRD = voltage reducing device. This function drops voltage when not welding to help prevent potential ARC start or shock when replacing an electrode. Normal output is 60v, while VRD drops the no-load voltage to roughly 24v. To turn the function on or off, you must be in the Stick Welding setting with Amperage setting at 108 amps, then press and hold the 2T/4T button. Illuminates GREEN when on.
2. **MIG Torch/Spool Gun Switch:** (MIG/TIG/ARC Switch Must be in MIG mode). Select for Wire Feed Torch or optional Spool Gun (not included)
3. **MIG/TIG/ARC (Stick) Switch:** Used to select between MIG, TIG or ARC (Stick) welding functionality.
4. **2T / 4T 2T/4T SWITCH:**
 - 2T:** For 2-step operation of short welding.
 - Depress trigger and hold in. Pre-flow and Arc begin.
 - To end arc, release trigger and Arc will terminate followed by the predetermined post flow.
 - 4T:** For 4-step operation of long welding.
 - Depress trigger and hold in. Pre-flow and Arc begin.
 - Once the Arc has started, release the trigger. The Arc will stay lit.
 - To terminate the Arc, depress trigger once again and hold until Arc termination is desired and release the trigger.
 - Releasing the trigger at this point will terminate the Arc, followed by the predetermined post flow.
5. **Inductance Setting Knob:** The inductance setting controls the rate of current rise following the short-circuit state. That is during the time when the wire is short circuiting into the weld puddle. This setting affects the arc time too. That is the amount of time the short circuit cycle spends arcing and providing heat to the puddle A high inductance setting increases the time of each individual arc cycle and therefore can improve wetting of the puddle. This produces a "softer" puddle which is excellent for smooth fillet welds. A low inductance increases the frequency of each short circuit/arc cycle and can be useful for pinpointing a narrow bead in some joints. Offers greater penetration however it will produce more spatter.
6. **Voltage Control Knob:** Controls the voltage output range for MIG; 15 to 30 Volts. Voltage value is indicated by the digital LED display.
7. **Wire Speed / Arc Control Knob:** Dual Function Control and Display
 - Press "A" Button to select Arc Current. The Knob controls the Amperage output while the Digital LED displays the Amperage value. Current Range; 15 to 250 AMPS.
 - Press "Inches/Min" Button to select Wire Speed. The Knob controls the Wire Speed when MIG welding while the Digital LED displays the Wire Speed value. Speed range; 78 n/min to 627 in/min.
8. **Overload Indicator:** Illuminates GREEN when Duty Cycle has been exceeded, the Welder is overloaded or if other abnormalities exist.

MP250i Welding Guide

Should the instruction manual for this tool become lost or unavailable, contact Eastwood Tech @ 1-800-345-1178 and request document #21180Q

Welding Parameters																		
Material	Wire Type	Polarity	Shielding Gas	Wire Size	Voltage/Speed (inches per minute)													
					24ga 0.022"	22ga 0.028"	20ga 0.035"	18ga 0.049"	14ga 0.075"	1/8" 1.25"	3/16" 1.87"	1/4" 25"	3/8" 3.75"	1/2" 5"				
MIG	Steel	DCP	C25 (75% Ar / 25% CO2)	0.022" (0.6mm)	15/120	15.7/160	18/215	20/350	--	--	--	--	--	--	--	--		
				0.030" (0.8mm)	--	--	18/170	20/260	22/215	24/305	34/350	--	--	--	--	--	--	--
				0.035" (0.9mm)	--	--	18/170	19/170	22/260	24/305	26/350	--	--	--	--	--	--	--
	Flux Core E71T-11	DCEN	None	0.045" (1.2mm)	--	--	--	18/125	19/170	22/215	24/260	27/350	34/440	--	--	--	--	
				0.030" (0.8mm)	--	--	17/170	18/170	20/212	--	--	--	--	--	--	--	--	--
				0.035" (0.9mm)	--	--	18/170	20/200	22/260	24/350	--	--	--	--	--	--	--	--
Stainless Steel	DCP	C25 (75% Ar / 25% CO2)	0.045" (1.2mm)	--	--	--	18/125	22/260	24/350	28/395	30/485	--	--	--	--	--		
			0.030" (0.8mm)	--	--	20/350	22/395	24/440	26/530	--	--	--	--	--	--	--	--	
			0.035" (0.9mm)	--	--	22/215	22/260	24/305	26/350	28/440	--	--	--	--	--	--	--	
Aluminum	DCP	100% Ar	0.030" (0.8mm)	--	--	--	22/215	24/260	26/305	28/395	30/485	34/530	--	--	--	--		
			0.035" (0.9mm)	--	--	--	22/215	24/260	26/305	28/395	30/485	34/530	--	--	--	--	--	
			0.045" (1.2mm)	--	--	--	18/350	22/440	24/485	26/530	--	--	--	--	--	--	--	

Material	Shielding Gas	Tungsten Diameter	24ga (0.6mm) Amps.													
			22ga (0.8mm)	20ga (1.0mm)	18ga (1.25mm)	17ga (1.5mm)	14ga (2.0mm)	1/8" (2.0mm)	3/16" (3.0mm)	1/4" (4.0mm)	>5/32" (>4.0mm)					
Stainless Steel, Steel, Chromoly	Ar(99.99%) DCEN	1.6 / 1/16"	15	25	30	40	50	70	100	--	--	--	--	--	--	--
		2.4 / 3/32"	--	--	30	40	50	70	100	120	120-150	--	--	--	--	--
		3.2 / 1/8"	--	--	30	40	50	70	100	120	120-250	--	--	--	--	--

Material	Electrode Type	Electrode Diameter	17ga (1.5mm) Amps.									
			14ga (2.0mm)	1/8" (3.0mm)	5/32" (4.0mm)	1/16" (5.0mm)	1/4" (6.0mm)	>1/4" (>4.0mm)				
Stainless Steel, Steel	Acidic Electrode	3/32" (2.5mm)	30	50	70	90	--	--	--	--	--	--
		1/8" (3.2mm)	--	50	70	90	140	--	--	--	--	
		5/32" (4mm)	--	70	90	140	200	--	--	--	--	
		3/16" (5mm)	--	70	90	140	200	250	--	--	--	

Polarity	
MIG (DCP)	Flux-Cored (DCEN)
TIG (DCEN)	ARC (DCP)
	SPOOL (DCP)

Wire Coil Installation	
10 lb. / 44 lb. Wire Coil	

MIG Gun Consumables

Wire Diameter	Welding Current	Nozzle Distance (mm)	Gas Flow Rate(CO2)	Gas Flow Rate(Ar)
0.023"	10-50	1/4 - 5/16"	16-21	13-19
0.6mm	100-130	5/16 - 3/8"	21-30	16-21
0.030"	50-100	5/16 - 3/8"	17-25	13-19
0.8mm	100-160	3/8 - 1/2"	25-30	19-25
0.035"	70-100	3/8 - 1/2"	25-30	16-21
0.9mm	100-250	1/2 - 5/8"	30-40	21-32

TIG Torch Consumables

Tungsten Diameter	Welding Current	Distance between Tungsten and Workpiece	Gas Flow Rate(Ar)
1/16"	10-50	1/8"	12
1.6mm	50-100	3/16"	14
3/32"	30-80	1/8"	12
2.4mm	80-180	1/4"	16
1/8"	30-100	1/8"	14
3.2mm	100-250	1/4"	18

Welding description

MIG Welding
For material thickness greater than 1/4", adopting a grooved weld is preferred. Use a multi-pass welding process will insure proper penetration. For solid wire use DCEP and shielding gas. For flux core welding, use DCEN. Shielding gas is not needed for flux core welding but can be used.

TIG Welding
For material thickness greater than 5/32", adopting a grooved weld is preferred. Use a multi-pass welding process will insure proper penetration. When using welding carbon steel and stainless steel, AC is suitable for aluminum and aluminum alloy and other non-ferrous metals.

ARC Welding
For material thickness greater than 1/4", adopting a grooved weld is preferred. Use a multi-pass welding process will insure proper penetration. When using acidic electrodes, DCEP and DCEN can be used. Alkaline electrodes use DCEN and cellulose electrodes use DCEP.

Front panel instruction

- VRD Indicator: In Stick Mode, set current to 108A, press and hold 2T/AT Selector Button to turn ON/OFF
- MIG/TIG/ARC Selector Button
- MIG Torch/Spool Gun Selector Button
- 2T/AT Selector Button
- Inductance Adjustment Knob
- Voltage Adjustment Knob
- Current/Wire Speed Adjustment Knob
- Overload Condition Indicator
- Voltage Meter
- Current/Wire Speed Meter

FIG. 6

SET UP AND OPERATION FOR MIG WELDING

SET UP FOR MIG WELDING Installing the MIG Welding Gun

- Open the side door of the Welder and loosen the Welding Gun Thumb Screw (FIG 7).
- Slide the brass body of the Welding Gun in through the front of the Welder into the Welding Gun Power Connection located at the lower left front panel (FIG 8). Be sure to insert until it bottoms against the drive assembly or a gas leak may occur.
- Tighten the Welding Gun Torch Thumbscrew securely.
- Connect the male metal plug to the female Cannon Plug Connection on the front of the Welder (FIG 8).
- Switch the "MIG/TIG/ARC" Selector Button located on the Front Panel to the MIG Position and switch "MIG Torch/Spool Gun" Switch to "MIG Torch" (FIG 5).

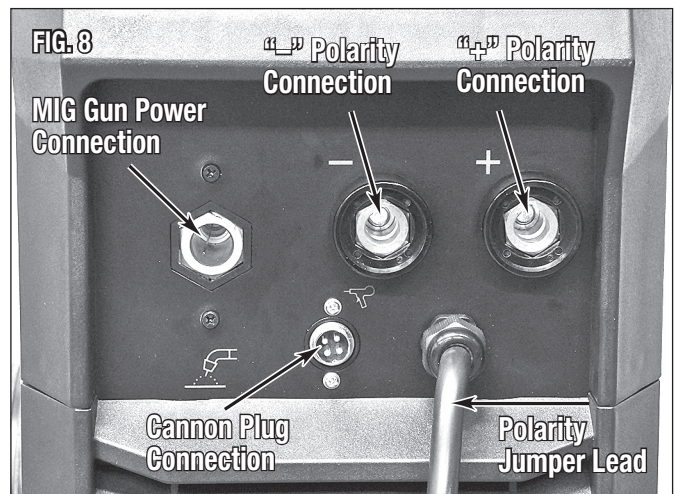
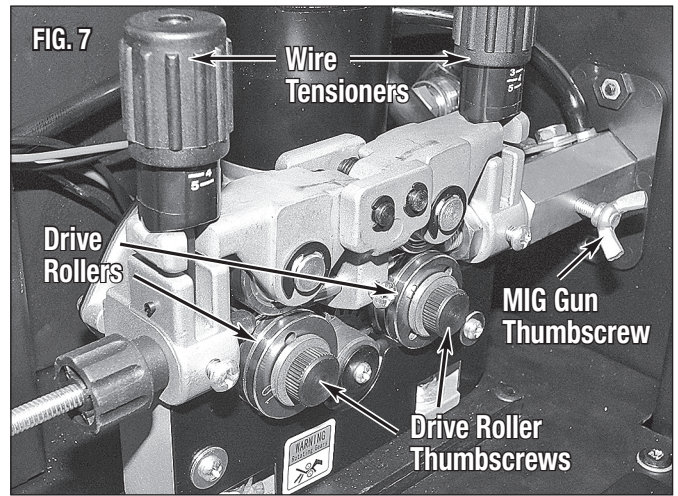

Installing the Ground Cable and Clamp for Solid Wire MIG with Shielding Gas MIG (DCEP) (Illustration MIG DCEP)

- Locate the Ground Clamp with Cable and connect the plug on the cable end to the (-) connector on the Front Panel of the Welder. To connect the plug, line up the key on the plug with the keyway on the socket of the Welder, insert the plug and twist Clockwise until it is tight (FIGS 6 & 8).
- Attach the MIG Torch connector to the MIG/TIG Torch connection on the Lower Left Front Panel. To connect the plug, line up the key on the plug with the keyway on the socket of the Welder, insert the plug and twist Clockwise until it is tight (FIG 6).
- Install the Polarity Jumper Lead into the (+) connector by inserting the keyed brass connector and rotating to lock in place (FIGS 6 & 8).

Changing the Polarity

To use a Flux Cored wire, the Polarity must be changed to the DCEN configuration:

⚠ DANGER ELECTRIC SHOCK CAN CAUSE INJURY OR DEATH!
• Disconnect Welder from power supply before beginning.

Flux-cored MIG (DCEN) (Illustration FLUX DCEN)

- Remove the Ground Clamp Cable connection from the lower Front Panel by rotating and pulling out.
- Install the Ground Clamp Cable connector by inserting the keyed brass connector into the (+) connector and rotating to lock in place (FIGS 6 & 8). Install the Polarity Jumper Lead into the (-) connector by inserting the keyed brass connector and rotating to lock in place (FIGS 6 & 8).

INSTALLING THE SHIELDING GAS SUPPLY

⚠ WARNING BUILDUP OF GAS CAN INJURE OR KILL!

- Shut off gas supply when not in use.
- Ensure adequate ventilation
- Do not weld in confined areas.
- Always turn your face away from valve outlet when opening cylinder valve.

⚠ WARNING CYLINDERS CAN EXPLODE IF DAMAGED!
Shielding gas cylinders contain gas under high pressure. If damaged, a cylinder can explode. As gas cylinders are a normal component of the welding process, use extra care to handle them carefully.

- Protect compressed gas cylinders from excessive heat, mechanical shocks, physical damage, slag, open flames, sparks and arcs. Keep away from any welding or other electrical circuits.
- Install cylinders in an upright position by securing to a specifically designed rack, cart or stationary support to prevent falling or tipping over.
- Never weld on a pressurized cylinder or explosion will occur.
- Use only correct shielding gas cylinders, regulators, hoses and fittings designed for the specific application; maintain them and all related components in good condition.
- Keep protective cap in place over valve except when cylinder is in use.
- Use proper equipment, procedures and have adequate help when moving or lifting cylinders.

Illustration
MIG DCEP

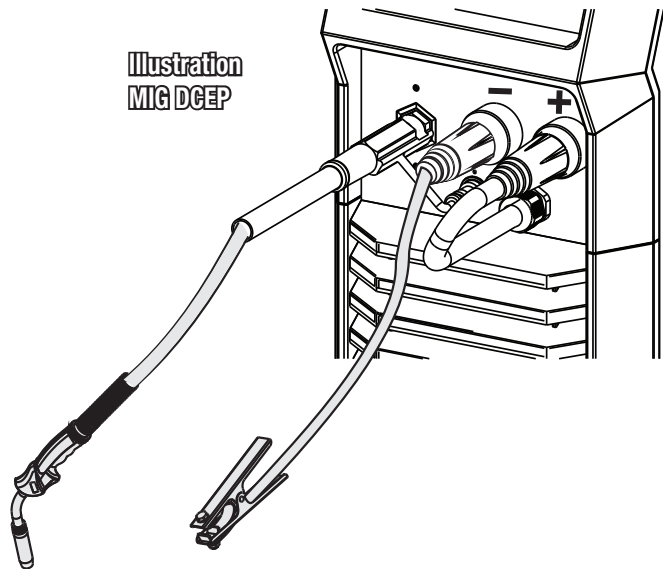
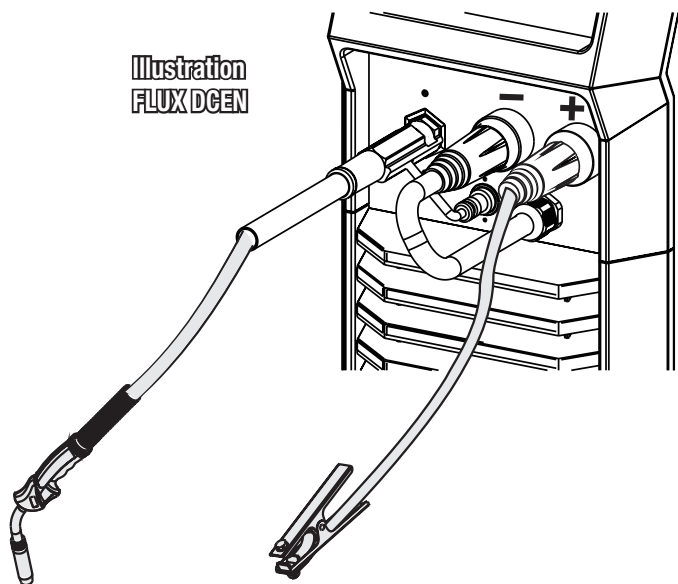
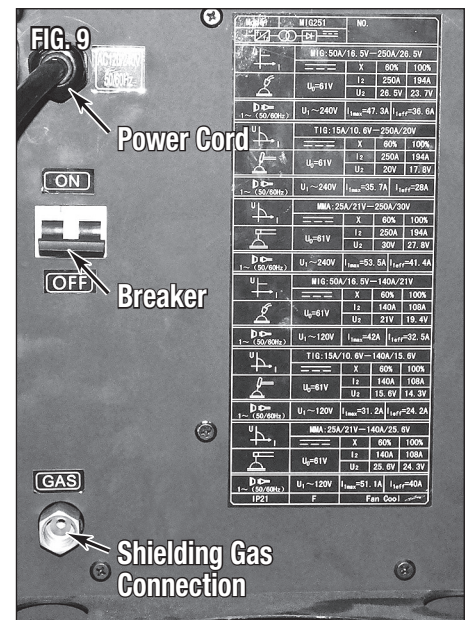

Illustration
FLUX DCEN



A Shielding Gas Bottle is NOT INCLUDED with your Eastwood MP250i but is necessary to weld using Solid Wire. It can be bought at most local Welding Supply Stores. Eastwood recommends the use of 75% Argon / 25% CO2 for shielding gas when MIG welding Steel, 100% Argon for Aluminum, and Tri-Mix (90% He / 7.5% Ar / 2.5% CO2) for Stainless Steel.

1. Place your Shielding Gas Bottle on the Rear Tray of the MP250i and mount it securely with the included Cylinder Retaining Chains so that the cylinder cannot fall over.
2. Remove the cap from the Shielding Gas Bottle.
3. Insert the large brass male fitting on the Shielding Gas Regulator (NOT INCLUDED, Eastwood #12238 recommended) into the female fitting on the Shielding Gas Bottle.
4. Tighten the fitting with a wrench until snug, do not over tighten.
5. Connect either end of the Gas Line included with your Eastwood MP250i to the fitting on the regulator and wrench tighten until snug.
6. Connect the other end of the gas line to the fitting on the rear of the Eastwood MP250i and wrench tighten until snug (FIG 9).
7. Check the gas line for leaks by slowly opening the valve on the gas bottle. When welding the valve on the bottle should always be all the way open.



DRIVE ROLLERS

The Eastwood MP250i is designed to use 0.030 to 0.045 wire and is equipped with two Dual-Groove Drive Rollers. As assembled, it will accept 0.030"/0.035" [0.8mm/0.09mm] wire. To use 0.040"/0.045" [1.0mm/1.2mm] wire, the Drive Rollers must be reversed.

To do so:

- Unthread two Thumbscrews.
- Pull Drive Rollers from shafts.
- The indented wire sizes are stamped on the faces of the Drive Rollers.
- Choose the wire size needed and slip the Drive Rollers back onto the shafts with the desired wire size stamping facing inward (FIG 7).
- Replace Thumbscrews.

WIRE SPOOL

The Eastwood MP250i can be used with either an 8" or a 12" wire spool.

To install an 8" or 12" Wire Spool

- Open the door of the Welder and remove the Spool Retaining Knob from the Wire Spool Spindle.
- Slide the Wire Spool onto the center of the Spindle (FIG 10). When doing so, be sure the Drive Pin of the Spindle is engaged with a spoke of the Spool.
- Reinstall the Spool Retaining Knob.
- To set the spool tension, incrementally tighten the Spool Retaining Knob until there is a slight resistance to spinning the wire spool on the spindle. (FIG 10). If the tension is set too loose the wire spool will freely spin on the shaft and unspool all of the wire. If the tension is too tight, the Drive Roller will have difficulty pulling the wire off the spool and some slipping may occur.

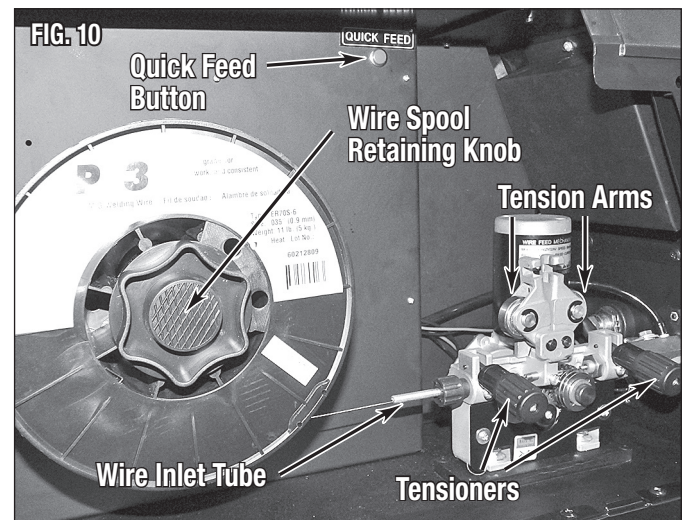

THREADING WIRE THROUGH THE DRIVE MOTOR TO THE WELDING GUN

⚠ DANGER ELECTRIC SHOCK CAN CAUSE INJURY OR DEATH!

- Disconnect Welder from power supply before beginning.

This Welder uses wire sizes ranging from 0.030" to 0.045" (0.8mm to 1.2mm). To install the welding wire follow the procedure outlined below:

1. Turn the power switch on the Upper rear Panel to the off position and unplug the Welder from the power supply.
2. Remove the Contact Tip and Nozzle from the end of the MIG Torch.
3. Unlock the Pressure Adjusters and raise the Tension Arms (**FIG 10**).
4. Pull out a length of welding wire from the wire spool carefully. **IMPORTANT NOTE:** Do not let go of the wire or the entire spool could unravel.
5. Cut off the small piece of the curved segment at the front of welding wire and straighten the welding wire approximately 3.0" long.
6. Thread the welding wire through the Wire Inlet Tube and over the wire Drive Rollers and into the Torch Hole (**FIG 10**).
7. Swing the Tension Arms back into place and reset the Pressure Adjusters. (Note and record the tension level numbers indicated for future reference)
8. Connect the Welder to a power supply and turn on the machine.
9. Set the Process Selector Button on the Front Panel to "MIG". Set the Wire Speed to about "5".
10. With the gun pointed away from you and others, depress the trigger to begin feeding wire. The Red, Quick Feed button located at the Upper Interior Panel may also be used (**FIG 10**). **NOTE:** Watch the drive roller to see if any slipping is occurring between the roller and the wire - if so turn the machine off, unplug it and tighten the Pressure Adjusters 1/4 turn and test again.
11. Once the wire exits the end of the torch, reinstall the contact tip and nozzle. Cut the wire about 1/4" from the end of the contact tip.

MIG WELDING OPERATION

⚠ DANGER ELECTRIC SHOCK CAN CAUSE INJURY OR DEATH!

- Improper use of an electric Welder can cause electric shock, injury and death! Read all precautions described in the Welder Manual to reduce the possibility of electric shock.
- Disconnect Welder from power supply before assembly, disassembly or maintenance of the torch, contact tip and when installing or removing nozzles.
- Always wear dry, protective clothing and leather welding gloves and insulated footwear. Use suitable clothing made from durable flame-resistant material to protect your skin.
- If other persons or pets are in the area of welding, use welding screens to protect bystanders from sparks.
- Always operate the Welder in a clean, dry, well ventilated area. Do not operate the Welder in humid, wet, rainy or poorly ventilated areas.
- The electrode and work (or ground) circuits are electrically "hot" when the Welder is on. Do not allow these "hot" parts to come in contact with your bare skin or wet clothing.
- Separate yourself from the welding circuit by using insulating mats to prevent contact from the work surface.
- Be sure that the work piece is properly supported and grounded prior to beginning an electric welding operation.
- Always attach the ground clamp to the piece to be welded and as close to the weld area as possible. This will give the least resistance and best weld.

⚠ DANGER WELDING SPARKS CAN CAUSE FIRE OR EXPLOSION!

- Electric welding produces sparks which can be discharged considerable distances at high velocity igniting flammable or exploding vapors and materials.
- Do not operate electric arc Welder in areas where flammable or explosive vapors are present.
- Do not use near combustible surfaces. Remove all flammable items within 35 feet of the welding area.
- Always keep a fire extinguisher nearby while welding.
- Use welding blankets to protect painted and or flammable surfaces; rubber weather-stripping, dash boards, engines, etc.
- Ensure power supply has properly rated wiring to handle power usage.

⚠ WARNING ELECTROMAGNETIC FIELDS CAN BE A HEALTH HAZARD!

- The electromagnetic field that is generated during arc welding may interfere with various electrical and electronic devices such as cardiac pacemakers. Anyone using such devices should consult with their physician prior to performing any electric welding operations.
- Exposure to electromagnetic fields while welding may have other health effects which are not known.

⚠ WARNING ARC RAYS CAN BURN!

- Arc rays produce intense ultraviolet radiation which can burn exposed skin and cause eye damage. Use a shield with the proper filter (a minimum of #11) to protect your eyes from sparks and the rays of the arc when welding or when observing open arc welding (see ANSI Z49.1 and Z87.1 for safety standards).
- Use suitable clothing made from durable flame-resistant material to protect your skin.
- If other persons or pets are in the area of welding, use welding screens to protect bystanders from sparks and arc rays.

⚠ WARNING FUMES AND WELDING GASES CAN BE A HEALTH HAZARD!

- Fumes and gasses released during welding are hazardous. Do not breathe fumes that are produced by the welding operation. Wear an OSHA-approved respirator when welding.
- Always work in a properly ventilated area.
- Never weld coated materials including but not limited to: cadmium plated, galvanized, lead based paints.

⚠ CAUTION HOT METAL AND TOOLS WILL BURN!

- Electric welding heats metal and tools to temperatures that will cause severe burns!
- Use protective, heat resistant gloves and clothing when using Eastwood or any other welding equipment. Never touch welded work surface, torch tip or nozzle until they have completely cooled.

Your Eastwood MP250i can be used to form a large number of different joints and welds all of which will require practice and testing before using on an actual project piece. This following welding process is just a baseline to get you started.

- Refer to the 'Suggested Settings' chart which is located inside the side door of your Eastwood Welder (also shown in **FIG 6** of this manual). From the chart select your baseline starting point for the recommended settings described in the chart.
- Connect your ground clamp to the work pieces that are to be welded. Make sure the ground clamp contacts are placed on a clean piece of metal free of paint, grease, rust, oils, etc. It is recommended to place your ground clamp as close to the weld area as possible.
- Assess your weld area and make sure the welding area is also cleaned of any paint, grease, rust, oils, etc.
- Plug in the Welder and move switch to the "ON" position.
- Depress the Welding Gun trigger pointing the welding gun away from your body and then let go of the trigger and cut the wire back to ~1/4" stick out length.
- Wearing your welding helmet, gloves, and long sleeve shirt and pants, put the end of the wire sticking out of the gun into the joint to be welded.
- Position the MIG Gun so that it is perpendicular to the base metal with ~20° tilt back.
- Depress the trigger to start the wire feed which starts the arc. **NOTE:** A push, perpendicular, or drag technique can be used to weld the pieces together; the type used depends on the type of joint as well as other influential conditions.
- Once you depress the trigger and the arc has started, you will notice a molten puddle will form; this puddle is the weld bead and will follow the motion of the MIG Gun. Watching the size of the puddle dictates how fast you should be moving with the torch. If you burn through the material you are either moving too slow or you need to make some setting adjustments to the Welder settings. If you're not penetrating the base metal you're either moving too fast or you need to make adjustments to the Welder settings.
- Release the trigger on the MIG Gun to stop the weld.
- After welding is complete, turn off the Welder and disconnect from power source.

SHEET METAL WELDING TECHNIQUES

When welding sheet metal a different approach is usually taken to account for how thin the metal is and it's susceptibility to warping. The technique most often used is called Stitch Welding and this process is described below:

- Clean the metal to be welded of any paint, rust, oil, grease, dirt or any other contaminants that may be on the surface of the piece.
- Secure the pieces to be welded in place using clamps. Be sure to leave a small gap between the two pieces of sheet metal for the weld to flow into, this will result in a lower bead height which will require minimal finishing.
- Consult the Suggested Settings Chart and set the Voltage and Wire Speed knobs appropriately.
- Get some pieces of scrap metal of the same thickness and verify that the settings will work for the specific weld you will be making.
- Once the settings have been fine-tuned, tack weld your final pieces in places and remove the clamps if they are in the way of the weld.
- The Stitch Welding technique can now be utilized which is basically a series of tacks connecting together. To perform the technique, trigger the gun to form a tack weld and then continue to trigger the gun on and off making a series of connected tack welds following along the path of the weld joint. Continue the series of tacks for an inch or so and then move to a different section of the weld and perform the process there. It is essential to keep moving around to spread out the heat making sure not to get one section too hot and warp the metal.
- Once the entire weld has been completed allow the metal to cool. If necessary follow up with a flap disc to grind the weld bead flush.

HEAVY GAUGE METAL WELDING TECHNIQUES

When welding heavy gauge metal, a continuous bead is formed using a 'push' method. This process is described below:

- Clean the metal to be welded of any paint, rust, oil, grease, dirt or any other contaminants that may be on the surface of the piece.
- Secure the pieces to be welded in place using clamps. Be sure to leave a small gap between the two pieces of metal for the weld to flow into, this will result in a lower bead height which will require minimal finishing. Any material thicker than 1/8" should be beveled using an angle grinder.
- Consult the Suggested Settings Chart and set the Voltage and Wire Speed knobs appropriately.
- Get some pieces of scrap metal of the same thickness and verify that the settings will work for the specific weld you will be making.
- Once the settings have been fine-tuned tack weld your final pieces in places and remove the clamps if they are in the way of the weld.
- When welding heavy gauge metal there are two basic approaches to creating the weld. The first is a continuous bead with steady gun movement along the length of the joint. The second type of weld is a Stringer or Weave bead. This is accomplished by moving the torch in a circular or zig zag pattern. Either of these techniques will create strong welds but in some cases the Stringer or Weave type will create a more aesthetically pleasing weld bead.
- Once the entire weld has been completed, allow the metal to cool. If necessary, follow up with a flap disc to grind the weld bead flush.

SET UP AND OPERATION FOR STICK WELDING

⚠ DANGER ELECTRIC SHOCK CAN CAUSE INJURY OR DEATH!

- Improper use of an electric Welder can cause electric shock, injury and death! Read all precautions described in the Welder Manual to reduce the possibility of electric shock.
- Disconnect Welder from power supply before assembly, disassembly or maintenance of the torch, contact tip and when installing or removing nozzles.
- Always wear dry, protective clothing and leather welding gloves and insulated footwear. Use suitable clothing made from durable flame-resistant material to protect your skin.
- If other persons or pets are in the area of welding, use welding screens to protect bystanders from sparks.
- Always operate the Welder in a clean, dry, well ventilated area. Do not operate the Welder in humid, wet, rainy or poorly ventilated areas.
- The electrode and work (or ground) circuits are electrically “hot” when the Welder is on. Do not allow these “hot” parts to come in contact with your bare skin or wet clothing.
- Separate yourself from the welding circuit by using insulating mats to prevent contact from the work surface.
- Be sure that the work piece is properly supported and grounded prior to beginning an electric welding operation.
- Always attach the ground clamp to the piece to be welded and as close to the weld area as possible. This will give the least resistance and best weld.

⚠ DANGER WELDING SPARKS CAN CAUSE FIRE OR EXPLOSION!

- Electric welding produces sparks which can be discharged considerable distances at high velocity igniting flammable or exploding vapors and materials.
- Do not operate electric arc Welder in areas where flammable or explosive vapors are present.
- Do not use near combustible surfaces. Remove all flammable items within 35 feet of the welding area.
- Always keep a fire extinguisher nearby while welding.
- Use welding blankets to protect painted and or flammable surfaces; rubber weather-stripping, dash boards, engines, etc.
- Ensure power supply has properly rated wiring to handle power usage.

⚠ WARNING ELECTROMAGNETIC FIELDS CAN BE A HEALTH HAZARD!

- The electromagnetic field that is generated during arc welding may interfere with various electrical and electronic devices such as cardiac pacemakers. Anyone using such devices should consult with their physician prior to performing any electric welding operations.
- Exposure to electromagnetic fields while welding may have other health effects which are not known.

⚠ WARNING ARC RAYS CAN BURN!

- Arc rays produce intense ultraviolet radiation which can burn exposed skin and cause eye damage. Use a shield with the proper filter (a minimum of #11) to protect your eyes from sparks and the rays of the arc when welding or when observing open arc welding (see ANSI Z49.1 and Z87.1 for safety standards).
- Use suitable clothing made from durable flame-resistant material to protect your skin.
- If other persons or pets are in the area of welding, use welding screens to protect bystanders from sparks and arc rays.

⚠ WARNING FUMES AND WELDING GASES CAN BE A HEALTH HAZARD!

- Fumes and gasses released during welding are hazardous. Do not breathe fumes that are produced by the welding operation. Wear an OSHA-approved respirator when welding.
- Always work in a properly ventilated area.
- Never weld coated materials including but not limited to: cadmium plated, galvanized, lead based paints.

⚠ CAUTION HOT METAL AND TOOLS WILL BURN!

- Electric welding heats metal and tools to temperatures that will cause severe burns!
- Use protective, heat resistant gloves and clothing when using Eastwood or any other welding equipment. Never touch welded work surface, torch tip or nozzle until they have completely cooled.

SET UP

⚠ DANGER ELECTRIC SHOCK CAN CAUSE INJURY OR DEATH!
• Disconnect Welder from power supply before beginning.

Polarity Selection

The Eastwood MP250i can weld in both Direct Current Electrode Positive (DCEP) and Direct Current Electrode Negative (DCEN). The electrode, or rod, when welding in DCEP is positive and the grounded surface is negative. This polarity is used with electrodes that specify it and is usually the most commonly used polarity when ARC welding for general purpose use. The electrode when welding in DCEN is negative and the grounded surface is positive. This polarity is used with electrodes that require using this polarity and is usually used for building up heavy deposits of material with less penetration.

ARC (DCEP) (Illustration ARC DCEP)

- Switch the “MIG/TIG/ARC” Selector Button located on the Front Panel to the ARC (Stick) Position.
- Remove any MIG or TIG Torch that may be connected.
- Remove the Polarity Jumper Lead if connected.
- Locate the Ground Clamp with Cable and connect the plug on the cable end to the Ground Cable Connector (-) on the Lower Front Panel of the Welder. To connect the plug line up the key on the plug with the keyway on the socket of the Welder, insert the plug and twist until it is tight.
- Locate the Electrode Holder with Cable and connect the plug on the cable end to the Electrode Holder Connector (+) on the Lower Right Front Panel of the Welder. To connect the plug line up the key on the plug with the keyway on the socket of the Welder, insert the plug and twist until it is tight.

ARC (DCEN):

- Locate the Ground Clamp with Cable and connect the plug on the cable end to the Ground Cable Connector (+) on the Lower Right Front Panel of the Welder. To connect the plug line up the key on the plug with the keyway on the socket of the Welder, insert the plug and twist until it is tight.
- Locate the Electrode Holder with Cable and connect the plug on the cable end to the Electrode Holder Connector (-) on the Lower Front Panel of the Welder. To connect the plug line up the key on the plug with the keyway on the socket of the Welder, insert the plug and twist until it is tight.

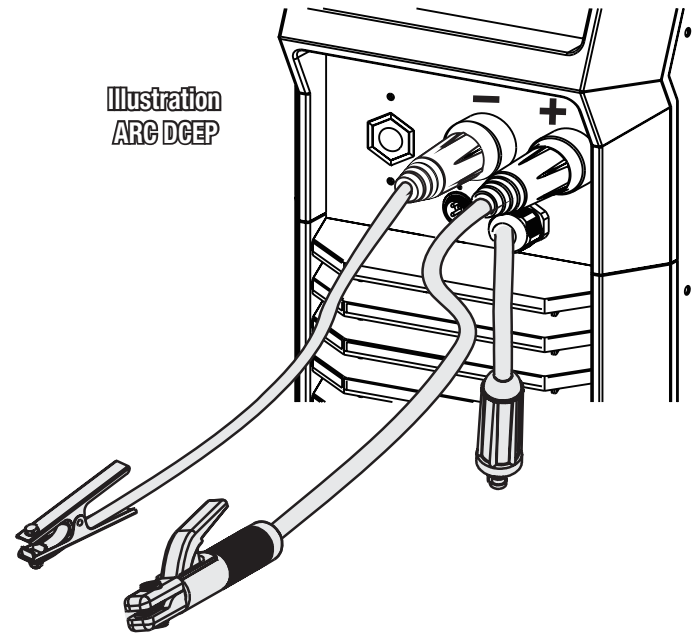

STICK WELDING OPERATION

ELECTRODE SELECTION

Before beginning welding with your Eastwood MP250i, you will need to purchase electrodes as these are a consumable item in the ARC welding process. There are a variety of different types of rods available and should be selected depending on the project on hand. The chart below is an overview of some of the most popular electrodes.

Electrode	Polarity	Usage
E6010	DCEP	This electrode works well for welding rusty, dirty, painted, or greasy steels.
E6011	DCEP	This electrode is a general purpose rod used for carbon and galvanized steel. It is recommended for use when deep penetration is necessary.
E6013	DCEP, DCEN	This electrode is a general purpose rod used for welding carbon steel with poor-fitting joints. It is capable of light penetration.
E7014	DCEP, DCEN	This electrode can be used where a high deposition is necessary along with fast travel speed. It is capable of light penetration.
E7018	DCEP	This electrode is best for use with clean, bare steel and is suitable for moderate penetration.

Electrode/Amperage Chart								
Electrode	Diameter		Amperage Range					
	IN	MM	MIN.	50 A	100 A	150 A	200 A	MAX.
6010 & 6011	3/32	2.4						
	1/8	3.2						
	5/32	4.0						
	3/16	4.8						
6013	1/16	1.5						
	5/64	2.0						
	3/32	2.4						
	1/8	3.2						
	5/32	4.0						
	3/16	4.8						
7014	3/32	2.4						
	1/8	3.2						
	5/32	4.0						
7018	3/32	2.4						
	1/8	3.2						
	5/32	4.0						
7024	3/32	2.4						
	1/8	3.2						
	5/32	4.0						
Ni-CI	3/32	2.4						
	1/8	3.2						
	5/32	4.0						
	3/16	4.8						
308L	3/32	2.4						
	1/8	3.2						
	5/32	4.0						

⚠ DANGER ELECTRIC SHOCK CAN CAUSE INJURY OR DEATH!

- Improper use of an electric Welder can cause electric shock, injury and death! Read all precautions described in the Welder Manual to reduce the possibility of electric shock.
- Disconnect Welder from power supply before assembly, disassembly or maintenance of the torch, contact tip and when installing or removing nozzles.
- Always wear dry, protective clothing and leather welding gloves and insulated footwear. Use suitable clothing made from durable flame-resistant material to protect your skin.
- If other persons or pets are in the area of welding, use welding screens to protect bystanders from sparks.
- Always operate the Welder in a clean, dry, well ventilated area. Do not operate the Welder in humid, wet, rainy or poorly ventilated areas.
- The electrode and work (or ground) circuits are electrically “hot” when the Welder is on. Do not allow these “hot” parts to come in contact with your bare skin or wet clothing.
- Separate yourself from the welding circuit by using insulating mats to prevent contact from the work surface.
- Be sure that the work piece is properly supported and grounded prior to beginning an electric welding operation.
- Always attach the ground clamp to the piece to be welded and as close to the weld area as possible. This will give the least resistance and best weld.

⚠ DANGER WELDING SPARKS CAN CAUSE FIRE OR EXPLOSION!

- Electric welding produces sparks which can be discharged considerable distances at high velocity igniting flammable or exploding vapors and materials.
- Do not operate electric arc Welder in areas where flammable or explosive vapors are present.
- Do not use near combustible surfaces. Remove all flammable items within 35 feet of the welding area.
- Always keep a fire extinguisher nearby while welding.
- Use welding blankets to protect painted and or flammable surfaces; rubber weather-stripping, dash boards, engines, etc.
- Ensure power supply has properly rated wiring to handle power usage.

⚠ WARNING ELECTROMAGNETIC FIELDS CAN BE A HEALTH HAZARD!

- The electromagnetic field that is generated during arc welding may interfere with various electrical and electronic devices such as cardiac pacemakers. Anyone using such devices should consult with their physician prior to performing any electric welding operations.
- Exposure to electromagnetic fields while welding may have other health effects which are not known.

⚠ WARNING ARC RAYS CAN BURN!

- Arc rays produce intense ultraviolet radiation which can burn exposed skin and cause eye damage. Use a shield with the proper filter (a minimum of #11) to protect your eyes from sparks and the rays of the arc when welding or when observing open arc welding (see ANSI Z49.1 and Z87.1 for safety standards).
- Use suitable clothing made from durable flame-resistant material to protect your skin.
- If other persons or pets are in the area of welding, use welding screens to protect bystanders from sparks and arc rays.

⚠ WARNING FUMES AND WELDING GASES CAN BE A HEALTH HAZARD!

- Fumes and gasses released during welding are hazardous. Do not breathe fumes that are produced by the welding operation. Wear an OSHA-approved respirator when welding.
- Always work in a properly ventilated area.
- Never weld coated materials including but not limited to: cadmium plated, galvanized, lead based paints.

⚠ CAUTION HOT METAL AND TOOLS WILL BURN!

- Electric welding heats metal and tools to temperatures that will cause severe burns!
- Use protective, heat resistant gloves and clothing when using Eastwood or any other welding equipment. Never touch welded work surface, torch tip or nozzle until they have completely cooled.

- Set up a clean well lit work area.
- Prepare the parts to be welded by cleaning the weld joint area of any rust, dirt, grease, or paint.
- Select the proper electrode for the weld joint.
- Turn on the Welder and select the appropriate amperage. To determine proper amperage it is best to practice on some similar metals to set up the machine before welding on an actual part of value.
- Attach the ground clamp to a clean bare metal section on the work piece.
- Insert the electrode into the electrode holder being careful not to allow the electrode to contact the grounded area.
- To start welding an arc must be struck, to do this a motion similar to striking a match will have to be performed with the electrode. Slowly bring the electrode closer to the weld joint and then contact and drag the electrode across the piece to strike the arc. Once the arc has been struck you can continue feeding the electrode into the weld joint.
- While moving along the weld joint the electrode will burn down, while it is burning you will need to continue moving the electrode closer to the joint trying to keep a 1/8" gap between the end of the electrode and the weld joint. The electrode holder must be held so that the electrode is in a downward angle moving in the direction of the weld joint.
- To stop welding simply lift the electrode away from the work piece. When finished welding remove the electrode from the holder and turn off the Welder.

SET UP AND OPERATION FOR TIG WELDING

SHIELDING GAS CONNECTION FOR TIG TORCH

⚠ WARNING BUILDUP OF GAS CAN INJURE OR KILL!

- Shut off gas supply when not in use.
- Ensure adequate ventilation
- Do not weld in confined areas.
- Always turn your face away from valve outlet when opening cylinder valve.

⚠ WARNING CYLINDERS CAN EXPLODE IF DAMAGED!

- Shielding gas cylinders contain gas under high pressure. If damaged, a cylinder can explode. As gas cylinders are a normal component of the welding process, use extra care to handle them carefully.
- Protect compressed gas cylinders from excessive heat, mechanical shocks, physical damage, slag, open flames, sparks and arcs. Keep away from any welding or other electrical circuits.
- Install cylinders in an upright position by securing to a specifically designed rack, cart or stationary support to prevent falling or tipping over.
- Never weld on a pressurized cylinder or explosion will occur.
- Use only correct shielding gas cylinders, regulators, hoses and fittings designed for the specific application; maintain them and all related components in good condition.
- Keep protective cap in place over valve except when cylinder is in use.
- Use proper equipment, procedures and have adequate help when moving or lifting cylinders.

A Shielding Gas Bottle is NOT INCLUDED with your Eastwood MP250i TIG Torch Kit but is necessary for TIG welding. A Shielding Gas Bottle can be bought at most local Welding Supply Stores. Eastwood recommends the use of 100% Argon shielding gas when TIG welding Steel and Stainless Steel.

After connecting your Shielding Gas Regulator, (NOT INCLUDED, Eastwood #12238 recommended) the gas flow rate needs to be adjusted so that the proper amount of Shielding Gas is flowing over your weld. If there is too little gas flow there will be porosity in your welds as well as excessive spatter, if there is too much gas flow you will be wasting gas and may affect the weld quality.

- Place the Shielding Gas Bottle (NOT INCLUDED) on the Rear Wheel/Tray Assembly and secure it with the Upper and Lower Chains.
- Remove the cap from the Shielding Gas Bottle.
- Insert the large brass Male Fitting on the Shielding Gas Regulator (NOT INCLUDED, Eastwood #12238 recommended) into the Female Fitting on the Shielding Gas Bottle.
- Tighten the fitting with a wrench till snug, do not over tighten.
- Connect the Male Fitting of the Shielding Gas Inflow Line of the TIG Torch Assembly to the Female Fitting on the Gas Shielding Regulator.
- Tighten the fitting with a wrench till snug, do not over tighten.

TIG TORCH ASSEMBLY/DISASSEMBLY

Assembly:

- Select a Collet body that matches your Tungsten diameter size and thread it into the front of the Torch.
- Select a Collet that matches your Tungsten diameter size. Insert the Tungsten into the Collet and put the Collet and Tungsten back into the Torch.
- The Gas Shielding Nozzle size should be changed according to shielding gas requirements for the material being welded. Thicker material requires a larger Nozzle. Select the correct Gas Shielding Nozzle and thread it onto the Collet body.
- Install the long back cap to lock the Tungsten in place. Always make sure the Tungsten protrudes 1/8" to 1/4" beyond the Gas Shielding Nozzle.

Disassembly:

- Make sure the welder is turned OFF and unplugged.
- Remove the Back Cap from the Torch.
- If there is a Tungsten installed in the Torch pull it out of the front of the Torch.
- Slide the Collet out of the Torch.
- Unscrew and remove the Gas Shielding Nozzle.
- Unscrew and remove the Collet body.

SHARPENING THE TUNGSTEN

To avoid contamination of the Tungsten and ultimately the weld, it is imperative to have a dedicated grinding wheel used for Tungsten grinding only. A fine grit standard 6" synthetic stone grinding wheel on a bench top grinder is sufficient or specifically designed Tungsten Grinders are available.

- Shut off the welder.
- Make sure the Tungsten and Torch are sufficiently cooled for handling then loosen and remove the Back Cap then the Collet and remove the Tungsten from the FRONT of the Torch only. (Removing from the rear will damage the Collet).
- If the Tungsten is used and the end is contaminated, use pliers or a suitable tool to grip the Tungsten above the contaminated section and snap off the end of the Tungsten.
- Holding the Tungsten tangent to the surface of the grinding wheel, rotate the Tungsten while exerting light pressure until a suitable point is formed. The ideal tip will have the length of the conical portion of the sharpened area at 2-1/2 times the Tungsten rod diameter.
- Replace the Tungsten in the Collet with the tip extending 1/8"-1/4" beyond the Gas Shielding Nozzle, then re-tighten the Back Cap.

SET UP FOR TIG WELDING

⚠ DANGER ELECTRIC SHOCK CAN CAUSE INJURY OR DEATH!
• Disconnect Welder from power supply before beginning.

TIG (DCEN) (Illustration TIG DCEN)

- Switch the "MIG/TIG/ARC" Selector Button located on the Front Panel to the "TIG" Position (FIG 5).
- Connect the Ground Clamp Connector to the (+) on the Lower Right Front Panel of the Welder. To connect the plug line up the key on the plug with the keyway on the socket of the Welder, insert the plug and twist until it is tight (FIG 6 & 8).
- Attach the TIG Torch connector to the (-) connector on the Lower Front Panel of the Welder. To connect the plug line up the key on the plug with the keyway on the socket of the Welder, insert the plug and twist until it is tight (FIGS 6 & 8).

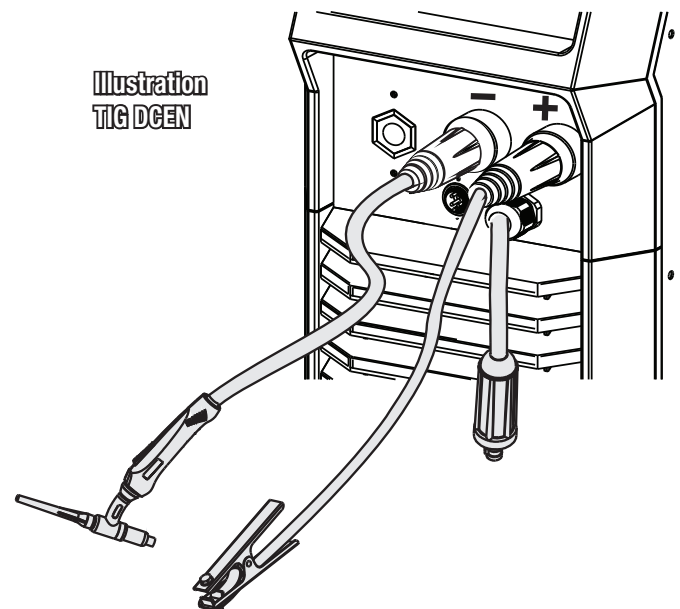

TIG WELDING

⚠ DANGER ELECTRIC SHOCK CAN CAUSE INJURY OR DEATH!

- Improper use of an electric Welder can cause electric shock, injury and death! Read all precautions described in the Welder Manual to reduce the possibility of electric shock.
- Disconnect Welder from power supply before assembly, disassembly or maintenance of the torch, contact tip and when installing or removing nozzles.
- Always wear dry, protective clothing and leather welding gloves and insulated footwear. Use suitable clothing made from durable flame-resistant material to protect your skin.
- If other persons or pets are in the area of welding, use welding screens to protect bystanders from sparks.
- Always operate the Welder in a clean, dry, well ventilated area. Do not operate the Welder in humid, wet, rainy or poorly ventilated areas.
- The electrode and work (or ground) circuits are electrically “hot” when the Welder is on. Do not allow these “hot” parts to come in contact with your bare skin or wet clothing.
- Separate yourself from the welding circuit by using insulating mats to prevent contact from the work surface.
- Be sure that the work piece is properly supported and grounded prior to beginning an electric welding operation.
- Always attach the ground clamp to the piece to be welded and as close to the weld area as possible. This will give the least resistance and best weld.

⚠ DANGER WELDING SPARKS CAN CAUSE FIRE OR EXPLOSION!

- Electric welding produces sparks which can be discharged considerable distances at high velocity igniting flammable or exploding vapors and materials.
- Do not operate electric arc Welder in areas where flammable or explosive vapors are present.
- Do not use near combustible surfaces. Remove all flammable items within 35 feet of the welding area.
- Always keep a fire extinguisher nearby while welding.
- Use welding blankets to protect painted and or flammable surfaces; rubber weather-stripping, dash boards, engines, etc.
- Ensure power supply has properly rated wiring to handle power usage.

⚠ WARNING ELECTROMAGNETIC FIELDS CAN BE A HEALTH HAZARD!

- The electromagnetic field that is generated during arc welding may interfere with various electrical and electronic devices such as cardiac pacemakers. Anyone using such devices should consult with their physician prior to performing any electric welding operations.
- Exposure to electromagnetic fields while welding may have other health effects which are not known.

⚠ WARNING ARC RAYS CAN BURN!

- Arc rays produce intense ultraviolet radiation which can burn exposed skin and cause eye damage. Use a shield with the proper filter (a minimum of #11) to protect your eyes from sparks and the rays of the arc when welding or when observing open arc welding (see ANSI Z49.1 and Z87.1 for safety standards).
- Use suitable clothing made from durable flame-resistant material to protect your skin.
- If other persons or pets are in the area of welding, use welding screens to protect bystanders from sparks and arc rays.

⚠ WARNING FUMES AND WELDING GASES CAN BE A HEALTH HAZARD!

- Fumes and gasses released during welding are hazardous. Do not breathe fumes that are produced by the welding operation. Wear an OSHA-approved respirator when welding.
- Always work in a properly ventilated area.
- Never weld coated materials including but not limited to: cadmium plated, galvanized, lead based paints.

⚠ WARNING FUMES AND WELDING GASES CAN BE A HEALTH HAZARD!

- Fumes and gasses released during welding are hazardous. Do not breathe fumes that are produced by the welding operation.
- Prolonged inhalation of welding fumes above safety exposure limits can injure the lungs and other organs.
- Use enough ventilation and/or exhaust at the arc to keep fumes and gases from your breathing area.
- Use an OSHA approved respirator when welding in confined spaces or where there is inadequate ventilation.
- Never weld coated materials including but not limited to: cadmium plated, galvanized, lead based paints.

⚠ WARNING BUILDUP OF GAS CAN INJURE OR KILL!

- Shut off gas supply when not in use. Ensure adequate ventilation. Do not weld in confined areas. Always turn your face away from valve outlet when opening cylinder valve.

⚠ WARNING CYLINDERS CAN EXPLODE IF DAMAGED!

- Shielding gas cylinders contain gas under high pressure. If damaged, a cylinder can explode. As gas cylinders are a normal component of the welding process, use extra care to handle them carefully.
- Protect compressed gas cylinders from excessive heat, mechanical shocks, physical damage, slag, open flames, sparks and arcs. Keep away from any welding or other electrical circuits.
- Install cylinders in an upright position by securing to a specifically designed rack, cart or stationary support to prevent falling or tipping over.
- Never weld on a pressurized cylinder or explosion will occur.
- Use only correct shielding gas cylinders, regulators, hoses and fittings designed for the specific application; maintain them and all related components in good condition.
- Keep protective cap in place over valve except when cylinder is in use.
- Use proper equipment, procedures and have adequate help when moving or lifting cylinders.

⚠ CAUTION HOT METAL AND TOOLS WILL BURN!

- Electric welding heats metal and tools to temperatures that will cause severe burns!
- Use protective, heat resistant gloves and clothing when using Eastwood or any other welding equipment. Never touch welded work surface, torch tip or nozzle until they have completely cooled.

- Turn the Power Switch to the ON position.
- Slowly open the gas cylinder valve. NOTE: Always open valve fully to avoid shielding gas leakage.
- Open the valve built-in to the Torch Handle. Adjust the Shielding Gas Regulator. See MP250i Welding Guide (**FIG 6**) for Gas Flow Recommendations. Rotate Counter-clockwise to open, Clockwise to Close.
- Grounding is very important, place the Ground Cable Clamp on a clean, bare area of your work piece as close to the welding area as possible to minimize the chance of shock. Scrape, wire brush, file or grind a bare area to achieve a good ground to assure safety.
- Use a dedicated stainless steel brush or flap-disc to clean the areas to be welded. Do not use the brush or flap-disc for any other purpose.
- Making sure all your safety gear is in place (Welding Mask, Welding Gloves, non-flammable long sleeve apparel) and the area is completely free of flammable material.
- Although it is a matter of developing a personal style, a good starting point for best results is achieved by holding the tip at a 45° angle backward and approx. 20° to the right of the weld. Hold the Filler Metal Rod at a 60° angle to the Tungsten Tip. Never allow the Tungsten Tip to touch the welding surface or material rod. Doing so will quickly destroy the tip and contaminate the weld. If this happens, remove the Tungsten and regrind the tip. It is best to hold the Tungsten tip 1/8" from the surface.
- With your Welding Shield and all safety gear in place, practice "Forming a Puddle" with the Tungsten Tip. Once you become familiar with this step. Practice the "Dip and Pull" technique with the Filler Metal Rod and Torch. "Dip and Pull" is the practice of forming a puddle, moving the Torch while maintaining the puddle and adding filler rod metal to the puddle by "dipping and pulling" as you go; being careful not to allow the Tungsten to contact the puddle or rod.
- To stop welding, pull the Tip back over the weld approx. 1/2" [13mm] then lift to break the arc. Keep shielding gas flow in place for approx. 10 seconds.
- Keep in mind that you MUST let the shielding gas flow over the weld for approx. 10 seconds. Failure to do so will allow the welded area to oxidize as it cools, compromising the weld integrity.
- Constantly be aware that TIG welding quickly generates heat in the work piece and Torch. Severe burns can quickly occur by contacting hot metal pieces.
- When done, shut off the Power Switch, close the valve in the Torch Handle then close the Shielding Gas Tank valve completely.

SET UP & OPERATION FOR SPOOL GUN WELDING (AVAILABLE SEPARATELY, NOT INCLUDED)

SET UP FOR SPOOL GUN WELDING

The Eastwood MP250i is designed to use a #20172 Spool Gun (Available Separately, Not Included) which allows for easy feeding of aluminum wire to expand your welding capabilities. This is an optional accessory and can be purchased separately from Eastwood.

Spool Gun (DCEP) (Illustration SPOOL DCEP)

- Connect the Ground Clamp with Cable to the (-) connector on the Front Panel of the Welder. To connect the plug, line up the key on the plug with the keyway on the socket of the Welder, insert the plug and twist Clockwise until it is tight (FIG 5).
- Attach the Spool Gun connector to the MIG Torch connection on the Lower Left Front Panel. To connect the plug, slide it into the socket of the Welder, and tighten the Thumbscrew until secure (FIGS 7 & 8).
- Install the Polarity Jumper Lead into the (+) connector by inserting the keyed brass connector and rotating to lock in place (FIGS 7 & 8).
- Switch the Selector Switch Button located on the Front Panel to the Spool Gun position.
- Refer to the Shielding Gas connection portion of MIG Set-Up & Operation, page 10.
- Connect Metal 4 Pin Plug to the connection on the front of the Welder (FIG 8).

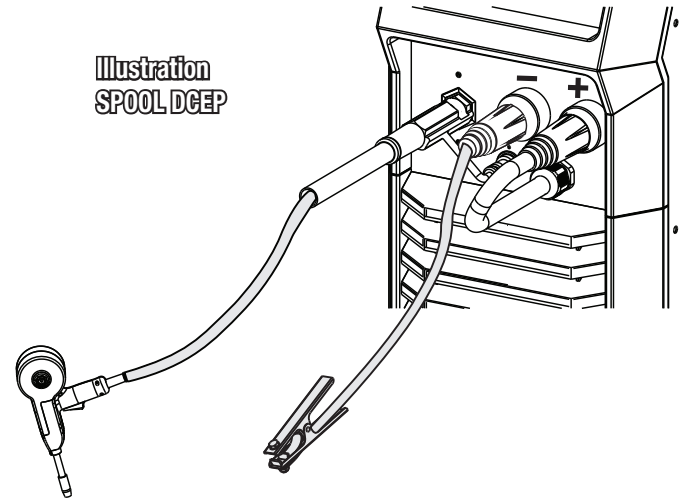

THREADING WELDING WIRE THROUGH THE SPOOL GUN

- Turn off Welder and unplug from power source.
- Set the switch on the Front Panel to the Spool Gun setting.
- Remove the Cover Retaining Knob and clear plastic Wire Spool Cover.
- Remove the Knob and Tension Spring that retains the Wire Spool
- Place wire spool on Spindle and replace the Tension Spring and Tensioner Knob then tighten until the point that the Wire Spool has some tension on it (FIG 12).
- Loosen the brass tensioner thumb screw until it is possible to feed the welding wire through the Drive Roller grooves (FIG 12).
- Feed the wire by hand from the Spool into the Wire Guide, past the Drive Rollers and into the Wire Inlet (FIG 12).
- Tighten the brass Wire Tension Thumb Screw until it applies light pressure onto the welding wire. If this is too tight it will deform the wire and cause feeding issues, if it is too loose the drive roller will slip on the wire (FIG 12).
- Remove the Nozzle and Contact Tip.
- Replace the Wire Spool Cover.
- Plug in welder to your power source and turn on the welder.
- Trigger the Spool Gun to feed the wire.
- Replace Contact Tip and Nozzle

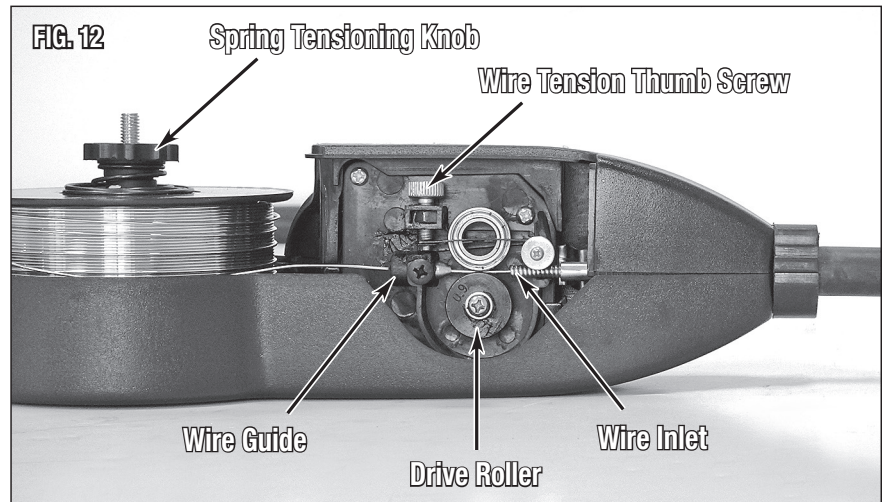

SPOOL GUN WELDING OPERATION

Your Eastwood MP250i can be used to weld aluminum utilizing the # 20172 Spool Gun (Not Included). The Spool Gun is sold as an accessory to the MP250i, and you will also need to purchase a cylinder of 100% Argon gas from your local welding supplier. This following welding process is just a baseline to get you started.

- Refer to the 'Suggested Settings' chart which is located inside the side door of your Welder. From the chart select your baseline starting point for the recommended settings described in the chart.
- Ensure that the polarity is configured for DCEP welding.
- Set the process selector switch to MIG.
- Set the MIG / Spool Gun Selector Switch to 'Spool Gun' on Front Panel.
- Connect your ground clamp to the work pieces that are to be welded. Make sure the ground clamp contacts are placed on a clean piece of metal free of paint, grease, rust, oils, etc. It is recommended to place your ground clamp as close to the weld area as possible.
- Assess your weld area and make sure the welding area is also cleaned of any paint, grease, rust, oils, etc. Aluminum has a layer of oxide on the surface that should be removed prior to welding.
- Plug in the Welder and turn the switch on the Rear Panel to the "ON" position.
- Open your gas valve on the bottle and adjust the flow rate if necessary.
- Depress the Spool Gun trigger for a few seconds pointing the welding gun away from your body and then let go of the trigger and cut the wire back to ~3/4" stick out length.
- Wearing your welding helmet, gloves, and long sleeve shirt and pants, put the end of the wire sticking out of the Spool Gun into the joint to be welded.
- Position the Spool Gun so that it is perpendicular to the base metal with 10-15° angle in the direction of push travel.
- Depress the trigger to start the wire feed which starts the arc. **NOTE:** When welding aluminum with a Spool Gun it is recommended to use a push technique. Using a drag technique will result in poor, dirty welds.
- When welding aluminum a spray arc transfer is preferred rather than short arc transfer that can be more commonly used on steels. This method involves using a longer wire stick out (~3/4"). When the Welder settings and technique have been dialed in the spray arc transfer should create a hissing sound and little or no spatter. Once positioned the trigger can be pulled and the weld started.
- Release the trigger on the Spool Gun to stop the weld.
- After welding is completed, close the valve completely on the Shielding Gas Bottle, turn Power Switch to the "OFF" position and unplug Welder.

OVERLOAD PROTECTION

Your Eastwood MP250i Welder is equipped with an internal overload breaker and an external circuit breaker. If the Duty Cycle is exceeded, the internal breaker will trip and stop power supply to the drive motor although the fan will still run to cool the unit. In the event of an overload, the Overload Indicator on the Front Panel will illuminate GREEN and the Circuit Breaker on the Rear Panel of the Welder will trip. This circuit breaker must be reset manually. Before resetting the circuit breaker button allow the Welder to cool for a minimum of 15 minutes.

TYPES OF WELD JOINTS

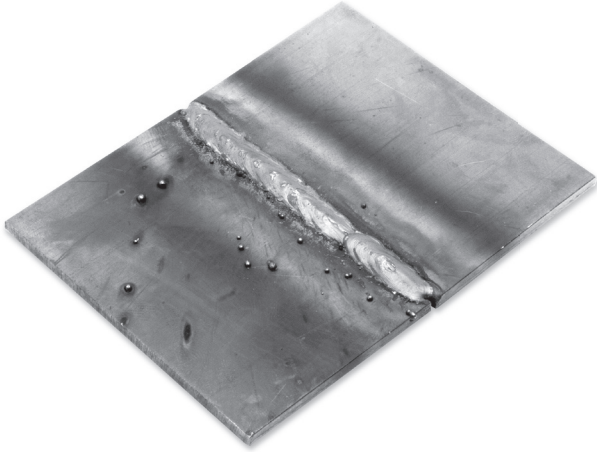

BUTT WELD is a joint between two pieces that are laying in the same direction.

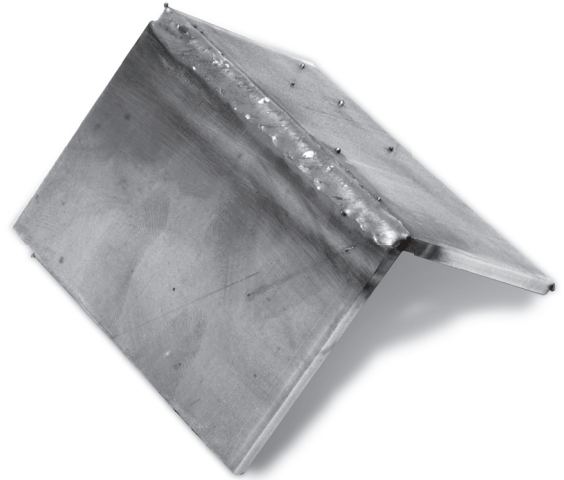

CORNER WELD is a joint between two pieces that meet at or near perpendicular at their edges.



EDGE WELD is a joint between two pieces where the edges are being joined.

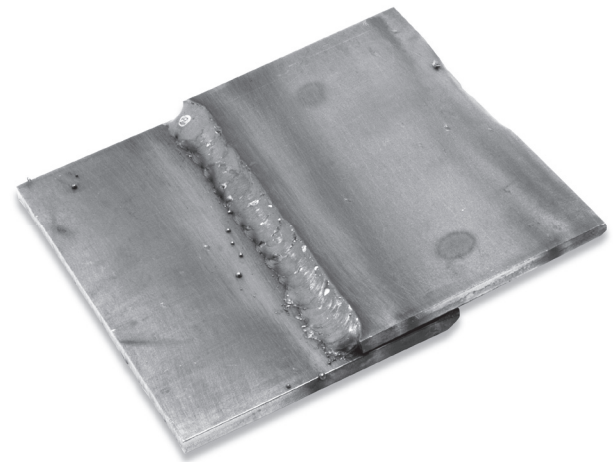

LAP WELD is a joint between two overlapping pieces.

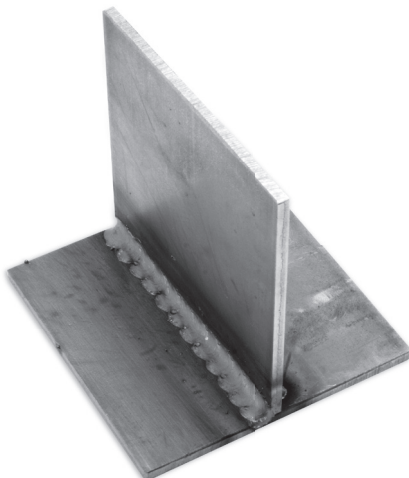

TEE WELD is a joint between two pieces where one is perpendicular to the other.

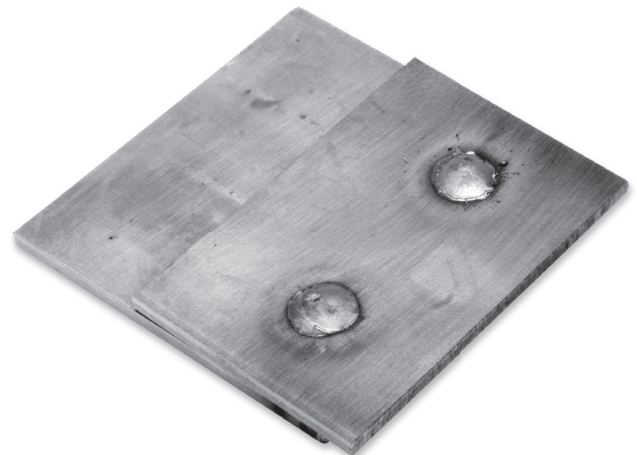

PLUG WELD is a joint which joins two overlapping pieces by filling in a hole punched in the top piece.

MIG WELD TROUBLESHOOTING

PROBLEM	CAUSE	CORRECTION
Burn Through	High Voltage	Adjust voltage output to lower setting.
	Fast Wire Speed	Adjust wire speed to slower setting.
	Slow Gun Travel	Increase your travel speed with the Welding Gun.
Lack of Penetration	Low Voltage	Adjust voltage output to higher setting.
	Slow Wire Speed	Adjust wire speed to faster setting.
	Fast Gun Travel	Slow your travel speed of the Welding Gun making sure to pull or drag the molten metal puddle.
	Excessive Wire Protruding	Move the Contact Tip on the Welding Gun closer to the work piece to shorten the length of exposed wire.
	Material Too Thick	The MP250i is rated for a maximum thickness of 1/2", exceeding this will result in poor penetration.
Poor Material Prep	If welding heavy gauge metals, it may be necessary to increase the welding gap between the two pieces and also bevel the edges on the weld side of the pieces.	
Excessive Penetration	High Voltage	Adjust voltage output to lower setting.
	Fast Wire Speed	Adjust wire speed to slower setting.
	Slow Gun Travel	Increase your travel speed with the Welding Gun.
Warping	Lack of Tack Welds	Tack weld the pieces in multiple areas to keep the pieces from pulling apart.
	No Clamping	Use welding clamps to secure the pieces in the proper shape.
	Poor Technique	To prevent warping, allow the workpiece to cool after welding small sections at a time. Move your welding areas around by not completing all the welding in one section all at once, rather, welding a small amount in one area and then move to another section area to spread out the heat in the piece.

STICK WELD TROUBLESHOOTING

PROBLEM	CAUSE	CORRECTION
Electrode Sticking	Arc Too Short	While welding, keep the ignited end of the electrode further from the weld joint.
	Current Too Low	Adjust the current on the front of the Welder to a higher current setting.
Holes in Weld Bead (Porosity)	Arc Too Long	While welding, keep the ignited end of the electrode closer to the weld joint,
	Moisture in Electrode	Replace electrode with a new one.
Excessive Spatter	Arc Too Long	While welding, keep the ignited end of the electrode closer to the weld joint,
	Current Too High	Adjust the current on the front of the welder to a lower current setting.
Poor Penetration	Poor Joint Preparation	Clean the weld joint of any dirt, grease, paint or other possible contaminants. If the pieces being Welder are of a heavy gauge it may be necessary to bevel the edges of the pieces.
	Current Too Low	Adjust the current on the front of the welder to a higher current setting.
	Travel Speed Too Fast	Slow down the travel speed of the electrode while welding.
GREEN Overload Indicator Illuminated	Duty Cycle Exceeded	Allow the Welder to cool for a minimum of 15 minutes before attempting to use again.

TIG WELDING TROUBLESHOOTING

PROBLEM	CAUSE	CORRECTION
Arc is Triggered but Will Not Start	Incomplete Circuit	Check Ground connection. Make sure that the ground is on a freshly cleaned surface and close to the welding area. It is suggested to weld towards the ground connection.
	Incorrect Tungsten	Consult chart for proper Tungsten for the base metal being welded. In most cases Thoriated will be used for all steels.
	No Shielding Gas	Make sure the shielding gas cylinder is turned all the way open and set at the correct flow rate.
Arc wanders and it is Hard to Concentrate Heat in a Specific Area	Poorly Prepped Tungsten	Follow guidelines for prepping Tungsten.
	Poor Gas Flow	Adjust the flow rate of the shielding gas (refer to settings chart). Check for loose fittings where gas could be leaking.
	Contaminated Tungsten	Remove Tungsten from Torch, break off contaminated section, and sharpen.
	Incorrect Arc Length	Make sure the Tungsten is held 1/8 to 1/4 inch off the work piece.
	Incomplete Circuit	Check Ground connection. Make sure that the ground is on a freshly cleaned surface and close to the welding area. It is suggested to weld towards the ground connection.
Contaminated Base Metal	Clean base metal making sure to remove any oil, debris, coatings, or moisture. If base metal is aluminum make sure all of the oxide is removed using either a dedicated stainless brush or flap wheel.	
Porosity in Weld Bead	Poor Gas Flow	Adjust the flow rate of the shielding gas. Check for loose fittings where gas could be leaking.
	Contaminated Filler Metal	Clean filler metal making sure to remove any oil, debris, or moisture.
	Contaminated Base Metal	Clean base metal making sure to remove any oil, debris, coatings, or moisture.
	Poor Shielding	Make sure to be in an area with no wind and with any fans turned off. Wind or fans will blow the shielding gas away from the weld causing porosity.
	Incorrect Tungsten Exposure	Adjust the Tungsten so that 1/8" to 1/4" inch protrudes from the Collet.
Contamination in Weld Bead	Contamination Tungsten	Remove Tungsten from Torch and break off contaminated section and sharpen.
	Contaminated Filler Metal	Clean filler metal making sure to remove any oil, debris, or moisture.
	Contaminated Base Metal	Clean base metal making sure to remove any oil, debris, coatings, or moisture. If base metal is cold rolled steel make sure to remove any mill scale.
Melting Tungsten	Poor Gas Flow	Adjust the flow rate of the shielding gas. Check for loose fittings where gas could be leaking.
	Wrong Size Tungsten	Increase Tungsten diameter. Refer to chart for proper sizing.
	Incorrect Shielding Gas	Only use 100% Argon when TIG Welding.
Poor Penetration	Low Voltage	Voltage setting is too low for material/thickness. Increase as needed.
Tungsten Contaminated	Contact of Tungsten with Base Metal	Keep Tungsten 1/8 to 1/4 inch from the base metal. If Tungsten comes in contact break off end and sharpen immediately.
Poor Weld Appearance	Incorrect Positioning	The angle between the filler metal and the Torch must be less than 90 degrees otherwise the filler metal will prematurely melt and glob off causing poor weld appearance.

TIG WELDING TROUBLESHOOTING

PROBLEM	CAUSE	CORRECTION
Crater in the End of the Weld Bead	Insufficient Shielding	Keep the Torch on the base metal while the post flow shielding gas flows to protect and cool the metal and Tungsten.
	Not Enough Filler Material	Reduce current and add more filler at end of weld. It may also be beneficial to back step to ensure no crater will form.
Weld Bead is Cracking	Too Much Heat in Material	Reduce heat and allow more time between passes.
	Base Metal is Absorbing Too Much Heat	Preheat base metal (consult welding codes for requirements)
	Incorrect Filler Wire	Use appropriate filler wire type and diameter for the joint being welded.
Material is Warping	Insufficient Clamping	Clamp work piece tightly and weld while clamps are in place.
	Insufficient Tack Welds	Add more tack welds until rigidity and stiffness is developed.
	Too Much Heat in Material	To reduce heat it is best to spread the welding out around the area. This can be done by using stitch welding techniques, alternating sides, and/or taking your time and allowing the pieces to cool between passes.

ACCESSORIES

CONSUMABLE ITEMS

- #20318 0.030" Contact Tips (5 Pack)
- #30652 0.045" Contact Tips (5 Pack)
- #30651 0.035" Contact Tips (5 Pack)
- #20572 Nozzle
- #20281 MIG Consumables Kit (2 Nozzles, 10 Contact Tips)

OPTIONAL ITEMS

- #12238 Gas Regulator
- #20172 Spool Gun
- #13203 Auto Darken Welding Helmet
- #13212 Large View Auto Darken Welding Helmet
- #12957 Welding Helmet Bag
- #12589, #12590 Top Grain Cowhide 4" Cuff Welding Gloves (M/L)
- #12762 L/XL/XXL Welding Jacket
- #20640 10' Long Ground Cable Extension

If you have any questions about the use of this product, please contact

The Eastwood Technical Assistance Service Department: 800.544.5118 >> email: techhelp@eastwood.com
 PDF version of this manual is available online >> eastwood.com/21180manual

The Eastwood Company 263 Shoemaker Road, Pottstown, PA 19464, USA
 US and Canada: 800.345.1178 Outside US: 610.718.8335
 Fax: 610.323.6268 eastwood.com