

Eastwood[®]

DO THE JOB RIGHT.[®]

Item #21320

ROD FORMING TOOL

INSTRUCTIONS

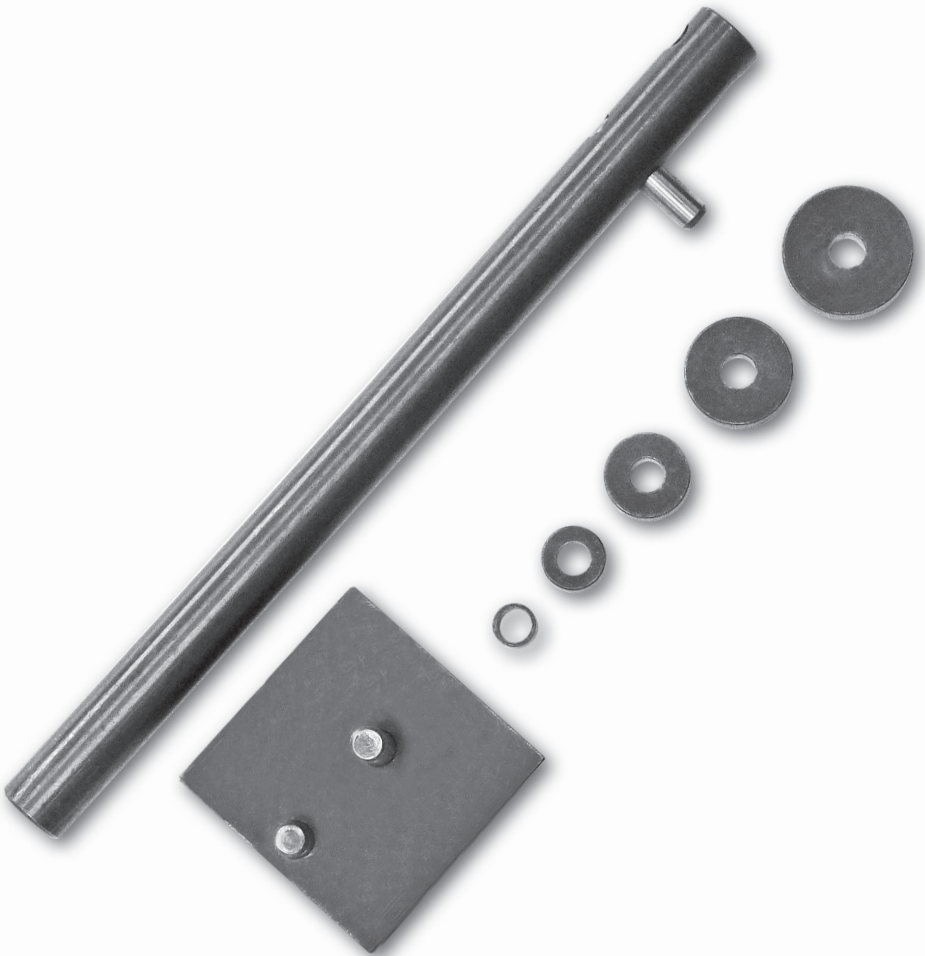

The **EASTWOOD ROD FORMING TOOL** is a high quality, industrial style tool capable of generating a powerful leveraged force to create 180° or greater repeatable bends in mild steel and aluminum rods up to 3/8" diameter and flat stock up to 1/2" wide and 3/16" thick.

CONTENTS

- (1) Pin Base (Center Pin = 0.38" Diameter/0.19" Radius) [A]
- (1) Forming Handle [B]
- (1) 1.5" Diameter/0.75" Radius Die [C]
- (1) 1.25" Diameter/0.63" Radius Die [D]
- (1) 1" Diameter/0.5" Radius Die [E]
- (1) 0.75" Diameter/0.38" Radius Die [F]
- (1) 0.5" Diameter/0.25" Radius Die [G]

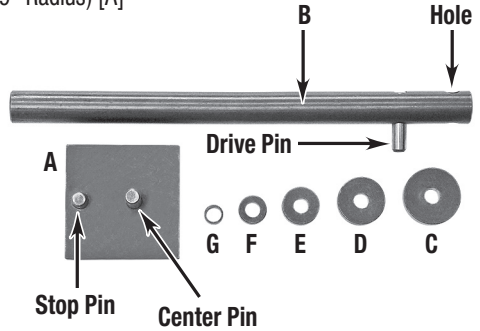

SPECIFICATIONS

- Maximum Round Stock Diameter:** 3/8"
- Maximum Flat Stock Material Width:** 1/2"
- Maximum Flat Stock Material Thickness:** 3/16" for 1/2" wide mild steel or 1/4" for 1/4" wide mild steel
- Maximum Handle Length:** 12"

SAFETY INFORMATION

The following explanations are displayed in this manual, on the labeling, and on all other information provided with this product:

⚠ DANGER

DANGER indicates a hazardous situation which, if not avoided, will result in death or serious injury.

⚠ WARNING

WARNING indicates a hazardous situation which, if not avoided, could result in death or serious injury.

⚠ CAUTION

CAUTION used with the safety alert symbol, indicates a hazardous situation which, if not avoided, could result in minor or moderate injury.

⚠ NOTICE

NOTICE is used to address practices not related to personal injury.

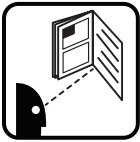

⚠️ READ INSTRUCTIONS

- Thoroughly read and understand this manual before using.
- Save for future reference.



⚠️ WARNING INJURY HAZARD!

- This tool has leveraged rotating components that generate greatly amplified crushing and bending forces which can quickly cause severe injury! Keep fingers and hands away from moving parts when operating.
- High external torque loads are placed on the Rod Forming Tool during operation. The tool cannot be operated without adequate support or severe personal injury or property damage can occur if it should suddenly become dislodged or moves while in use. Before beginning ANY work with this tool, it is absolutely necessary that it be securely clamped in a well-anchored vice.
- Strenuous physical force may need to be applied to the Rod Forming Tool during use. Failure to ensure proper footing can quickly result in a fall which could inflict serious personal injury or property damage. Always work in a clean, uncluttered environment.
- Be sure there is sufficient working room around the tool to allow for safe handling of various lengths of rod or tubing.
- The Eastwood Rod Forming Tool is equipped with a specifically designed Handle length for sufficient bending force. DO NOT add pipe, bars or any other devices which would add additional length to the Handle to increase bending force. This will exceed the design limits of the tool and can result in serious injury and/or component failure.



⚠️ CAUTION CUT HAZARD!

- Handling sharp metal can cause serious cuts. Wear thick, well-fitting work gloves to prevent cuts from handling sharp metal.



⚠️ CAUTION EYE INJURY HAZARD!

- Pieces of mill scale, rust and other debris may be ejected from the work-piece during operation. Wear ANSI approved eye protection while operating.

⚠️ NOTICE

- Excessive resistance while operating could indicate a defect with the workpiece material or broken or damaged Rod Forming Tool components. To avoid injury, stop work immediately and inspect workpiece material for nicks, dents, welds, excessive scale or remaining coatings. Clean or repair as necessary or discard and begin with a new piece. Also, inspect Rod Forming Tool components for looseness or damage.

SET-UP

⚠ WARNING

Strenuous external torque loads are placed on the Rod Forming Tool during operation. The tool cannot be operated without adequate support or severe personal injury or property damage can occur if it should suddenly become dislodged or moves while in use. Before beginning ANY work with this tool, it is absolutely necessary that it be securely mounted in a solid, level, well supported vice capable of withstanding the torque and side loads this tool is subjected to during use.

⚠ CAUTION

The Eastwood Rod Forming Tool can present a hand/finger pinch hazard and cause potentially serious injuries if dropped on feet. Avoid pinching hands while operating and wear thick, well-fitting work gloves to prevent cuts from handling sharp metal. The use of safety shoes is strongly recommended.

⚠ CAUTION

Make sure sufficient clearance is available around the vice area to allow a full swing of the Rod Former Handle.

MOUNTING BENDER IN VICE

- Open vice jaws (not included) to 2-1/2" Place the stepped section of the Pin Base [A] into the vice with the side flanges resting on top of the vice jaws (**FIG 1**).
- Close vice jaws and tighten securely.
- The Eastwood Rod Forming Tool is now ready for use.

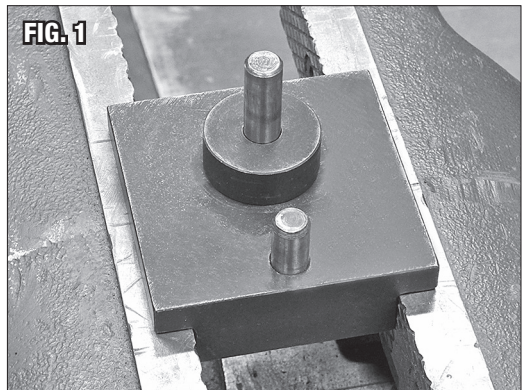

BENDER OPERATION

- Select the Die size to produce the desired bend radius and slip it down over the Center Pin.
NOTE: The Center Pin may be used without a Die to create a 3/16" radius bend (**FIG 1**).
- Attach the Forming Handle **[B]** by sliding the hole in the end over the Center Pin (**FIG 2**).
- Place material to be formed between the Stop Pin and the Die (**FIG 2**).
- Begin to apply pressure with the Drive Pin of the Forming Handle **[B]** to the side of the material in the direction of the bend (**FIG 3**).
- Continue to create the desired bend. Use a protractor (not included) to measure the planned angle.
- As the desired bend is achieved, check shape and angle and adjust if needed (**FIGS 3, 4**).
- Re-position or remove and switch position of workpiece to make additional bends (**FIG 5**).

NOTE: At this point, the basic operating instructions have been described and practice using the Eastwood Rod Forming Tool, on scrap material, is highly recommended. As with many metal working tools, a period of "trial and error" is needed to achieve a degree of proficiency in their use. Remember, a little time and material used at this step will avoid disappointing results on an actual project.

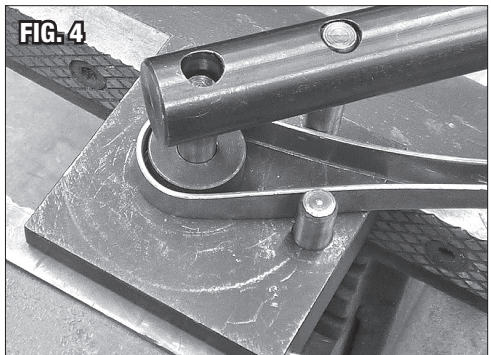
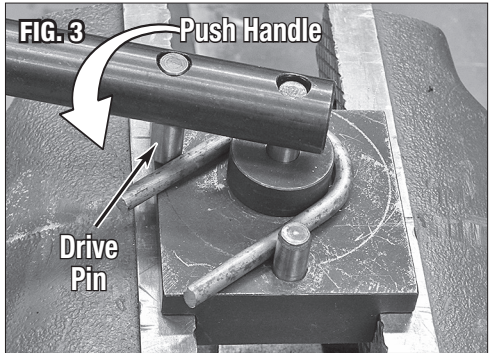
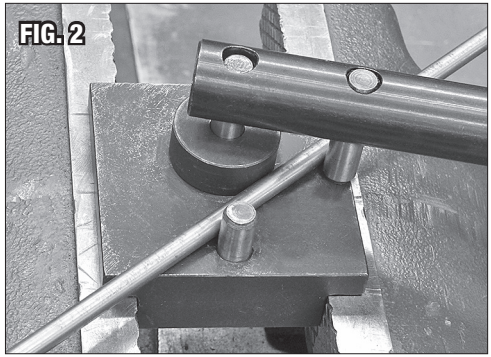

STORAGE

- Apply a thin film of light oil or rust-preventive to all bare steel areas.
- Store in a clean, dust-free, dry, dampness free area preferably covered with plastic sheeting.

MAINTENANCE

NOTE: Maintenance should be performed before each use.

- Clean dirt and debris from all pivot points.
- Check tightness of all hardware.
- Check operation for binding. Lubricate moving parts periodically with medium bodied chassis grease.

OPTIONAL ITEMS

- #51088 Shrinker/Stretcher Set
- #13475 Eastwood Electric Metal Shears
- #11797 Throatless Shear
- #14042 Versa Bend Sheet Metal Brake
- #20254 Eastwood 24" Slip Roll
- #28135 Heavy Duty Metal Bender
- #20521 4" Metal Bender

If you have any questions about the use of this product, please contact

The Eastwood Technical Assistance Service Department: 800.343.9353 >> email: techelp@eastwood.com

PDF version of this manual is available online >> eastwood.com/21320manual

The Eastwood Company 263 Shoemaker Road, Pottstown, PA 19464, USA

US and Canada: 800.343.9353 Outside US: 610.718.8335

Fax: 610.323.6268 eastwood.com