

Eastwood[®]

DO THE JOB RIGHT.[®]

Item #21525

TUNGSTEN GRINDER

INSTRUCTIONS



This **EASTWOOD TUNGSTEN GRINDER** features a long-lasting, double-sided, Diamond Grinding Wheel capable of providing over 200 tungsten sharpening's before requiring replacement. The high-speed electric motor allows the user to produce a finely sharpened point at the ideal 22.5° or 10° angle within seconds. The uniquely designed Grinding Guide accepts both 1/16" and 3/32" diameter tungsten electrodes for both breaking deformed tips, and prepping new tungstens.

CONTENTS

- (1) Tungsten Grinder with two-sided Diamond Grinding Wheel installed



SPECIFICATIONS

- Input Voltage:** 120 VAC, 60 Hz
- Motor:** 1.5 Amp
- Plug type:** 2-prong, polarized
- Certification:** ETL
- No-Load Speed:** 0-35,000 RPM (Variable Speed)

SAFETY INFORMATION

The following explanations are displayed in this manual, on the labeling, and on all other information provided with this product:

⚠ DANGER

DANGER indicates a hazardous situation which, if not avoided, will result in death or serious injury.

⚠ WARNING

WARNING indicates a hazardous situation which, if not avoided, could result in death or serious injury.

⚠ CAUTION

CAUTION used with the safety alert symbol, indicates a hazardous situation which, if not avoided, could result in minor or moderate injury.

⚠ NOTICE

NOTICE is used to address practices not related to personal injury.

SAFETY INFORMATION



⚠️ READ INSTRUCTIONS

- Thoroughly read and understand these product instructions before using this tool. Failure to follow all warnings can result in tool damage or serious physical injury.
- Keep these product instructions for future reference.



⚠️ WARNING HEALTH HAZARD!

- Dust and fine particles are generated while grinding which can contain hazardous or toxic substances. Breathing this dust can cause many serious respiratory health conditions. Always use NIOSH approved respiratory protection while using this tool.
- During the grinding of 2% thoriated tungsten electrodes, radioactive dust is created, posing the potential hazard of internal radiation exposure by inhalation or ingestion unless care is taken to control the dust. If grinding 2% thoriated tungsten, properly control and collect the dust; have an adequate ventilation system at the grinding station; and follow the manufacturer's warnings, instructions, and MSDS.



⚠️ WARNING EYE INJURY HAZARD!

- Rapidly rotating surfaces can eject metal particles and dust at high velocity. Always wear ANSI approved eye protection when operating this tool.



⚠️ WARNING HEARING DAMAGE HAZARD!

- The Eastwood Tungsten Grinder emits elevated sound levels while operating. Use ANSI approved ear protection when operating this tool.



⚠️ WARNING INJURY HAZARD!

- DO NOT attempt to operate the Tungsten Grinder without the Grinding Guide in place as severe injury can occur.



⚠ CAUTION INJURY HAZARD!

- This tool has high-speed, highly abrasive cutting surfaces which can quickly cause severe injury. Keep fingers and hands away from moving parts when operating. Wear thick, well-fitting work gloves and keep loose clothing, sleeves, cords, jewelry and hair away from moving parts.
- Always turn off Power Switch and disconnect tool from electrical supply when breaking off tungsten tips to prevent pieces of tungsten from falling into and being ejected from cutting area and potential severe injury.
- DO NOT exert excess force on tungsten while grinding as it can break and suddenly eject sharp pieces at high velocity.
- Always turn off Power Switch and disconnect tool from electrical supply when flipping or changing Grinding Wheels to prevent accidental tool starting and potential severe injury.
- This tool could eject a trail of sparks at high speed which can ignite flammable materials or injure others nearby. Do not operate near flammable materials and keep all persons and pets away from the work area.
- Always hold the tungsten with open fingers while grinding as it can suddenly kick back causing hand puncture wounds. Wear thick, well-fitting work gloves.
- Always make sure the tool is securely held to avoid sudden movements which could result in injury.
- Frequently inspect Grinding Wheel and tool condition. If cracks or chips develop, discontinue tool use immediately and replace damaged Wheel. ONLY USE replacement Wheels rated at 35,000 RPM or greater. Severe injury can result in the event of Grinding Wheel failure.



⚠ CAUTION VIBRATION INJURY HAZARD!

- This tool will vibrate during use! Repeated exposure to vibration may cause physical injury.

⚠ NOTICE

- Use care not to cover motor cooling slots with a gloved hand while in operation to avoid overheating.

FUNCTIONS

The Eastwood Tungsten Grinder features four machined slots with the bottoms angled at 22.5° or 10° which directs the tungsten to the ideal angle against the Diamond Grinding Wheel (FIG 1).

These four slots are 1/16" and 3/32" in width to accommodate standard tungsten sizes.

In addition, two notches (1/16" & 3/32") are cut into the top, outside edge of the Grinding Guide. These slots are designed to grip the burned end of tungsten rods for clean breakage (FIG 1).

OPERATION

- Slide the Speed Control/On-Off Switch to the OFF position.
- Plug the power cord into a 120 VAC, 60 Hz. Outlet.
- While holding the Eastwood Tungsten Grinder securely, slide the Speed Control/On-Off Switch to the 3rd position (FIG 2). This is the correct speed setting for tungsten grinding.

⚠ CAUTION

INJURY HAZARD!

Always hold the tungsten with open fingers while grinding as it can suddenly kick back causing hand puncture wounds.

⚠ NOTICE

Use care not to cover motor cooling slots with a gloved hand while in operation to avoid overheating.

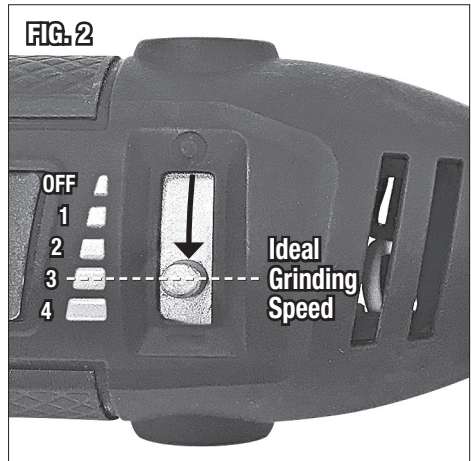
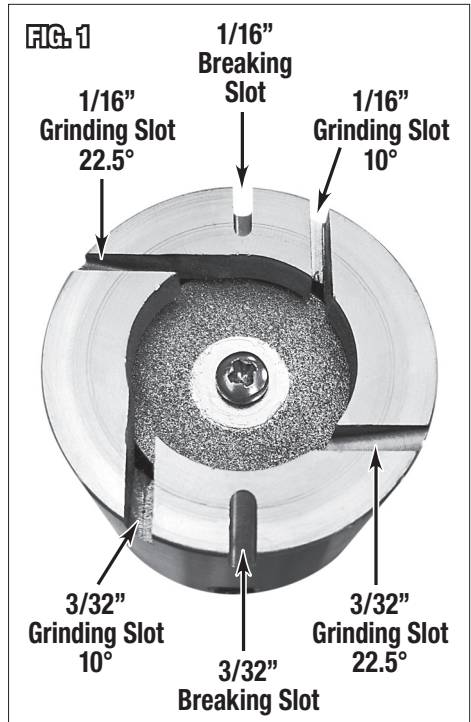

- When sharpening, be sure to grind past all contaminants or imperfections in the tungsten electrode.
- To begin grinding, allow several seconds for the motor to reach full speed then gently place the tungsten into the proper width slot (**FIG 3**).

⚠ CAUTION

INJURY HAZARD!

DO NOT exert excess force on Tungsten while grinding as it can break and suddenly eject sharp pieces at high velocity.

- Slowly and steadily allow the tungsten to contact the face of the Diamond Grinding Wheel while rolling the tungsten to create a sharpened tip. DO NOT force the tungsten, but allow the abrasive of the Diamond Grinding Wheel to do the work (**FIG 4**).
- When the grinding is complete, withdraw the tungsten then slide the Speed Control/On-Off Switch to the "OFF" position.

FIG. 3

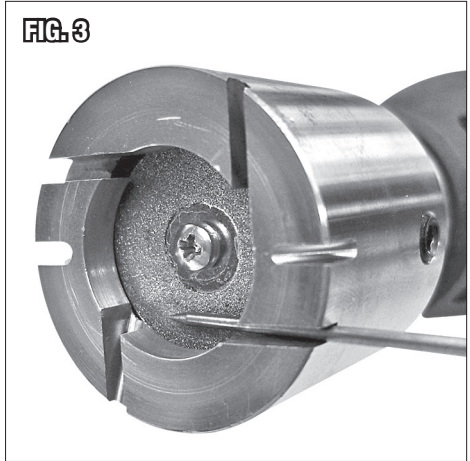

FIG. 4



BREAKING OFF BURNED TIPS ON TUNGSTEN

⚠ CAUTION

INJURY HAZARD!

Always turn off Speed Control/
On-Off Switch and unplug tool from
electrical supply when breaking off
tungsten tips to prevent pieces of
tungsten from falling into and being
ejected from cutting area and poten-
tial severe injury.

- Place the balled end of the tungsten into the proper width slot and quickly move the tungsten to the side to snap it off (**FIG 5**).

FIG. 5



FLIPPING & REPLACING DIAMOND GRINDING WHEEL

On average, each side of the Wheel will achieve 100 tungsten sharpening's. If the Wheel decreases in performance, flip or replace the wheel. To do so, follow the following instructions.

⚠ WARNING

INJURY HAZARD!

DO NOT attempt to operate the Tungsten Grinder without the Grinding Guide in place as severe injuries can occur.

⚠ CAUTION

INJURY HAZARD!

Always turn off Speed Control/ On-Off Switch and unplug tool from electrical supply when flipping or changing Grinding Wheels to prevent accidental tool starting and potential severe injury.

- Using a 3mm Hex Key (not included), loosen the four Retaining Set-Screws (**FIG 6**).
- Remove the Grinding Guide and set it aside.
- Depress the Armature Lock Button and using a #1 Phillips screwdriver (not included), remove the Diamond Grinding Wheel Retaining Screw (**FIG 7**).
- Remove and flip the existing Diamond Grinding Wheel to reveal the fresh abrasive surface or replace with a new one (**FIG 8**).
- Re-install the Retaining Screw and tighten in place.

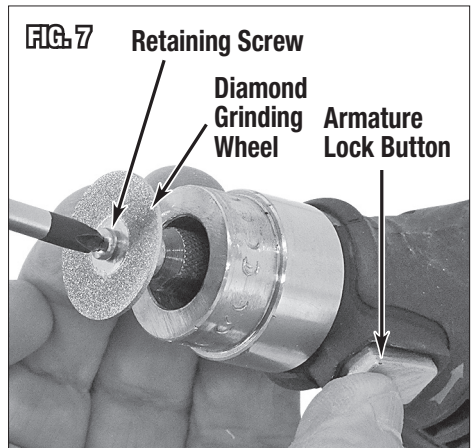
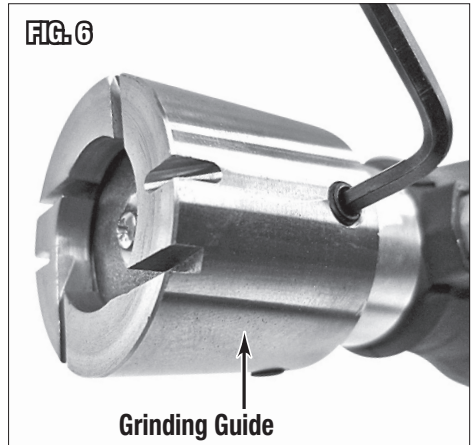

- Back out all four of the Retaining Set-Screws so that the ends are flush with the I.D. of the Grinding Guide (**Fig 9**).
 - Slip the Grinding Guide back over the Arbor Housing.
 - Tighten all four of the Retaining Set-Screws an equal amount so that the Grinding Guide opening is fully concentric with the Retaining Screw at the center of the Diamond Grinding Wheel (**Fig 10**).
- NOTE:** This is important to avoid contact between the Diamond Grinding Wheel and the I.D. of the Grinding Guide.
- The Eastwood Tungsten Grinder is now ready for use.

MAINTENANCE

IMPORTANT NOTE: The following maintenance should be performed before each use:

- Inspect Diamond Grinding Wheel for cracks, damage or premature wear.
- Clean dirt and debris from motor air cooling slots.
- Check Diamond Grinding Wheel Retaining Screw and Grinding Guide Retaining Set-Screws for tightness.

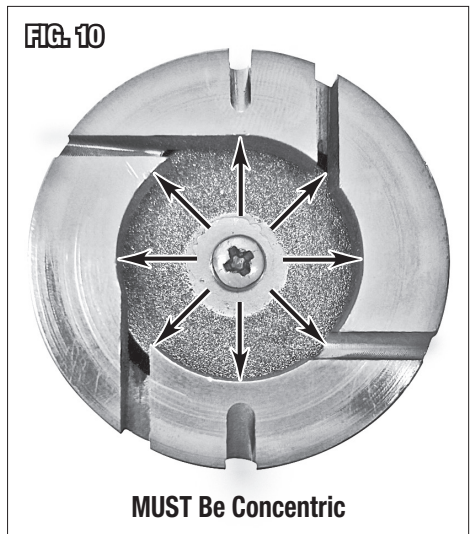

MUST Be Concentric

TROUBLESHOOTING

PROBLEM	CAUSE	CORRECTION
Does Not Run When Switch is Rotated	No electrical power to Grinder	Check 120 VAC input plug connection.
Motor Runs Too Slow/ Develops Low Power	Undersized or too long of an extension cord	Use only 16 gauge or larger cord. Limit length to 25'.
	Grinding Wheel contacting I.D. of Grinding Guide and binding	Adjust 4 Set Screws of Grinding Guide to center on Grinding Guide.
Excessive Noise and/or Vibration	Diamond Grinding Wheel is damaged	⚠ WARNING This is an extremely dangerous condition! Stop Use and replace Diamond Grinding Wheel!
	Arbor may be bent or damaged	Replace Arbor.
	Wheel is not concentric	Replace Wheel.
Tungsten Overheats	Excessive pressure being applied to tungsten	Allow Diamond Grinding Wheel to cut by rotation alone. Do Not Force.
	Dirt and debris buildup in motor cooling air slots	Use a brush or compressed air to remove debris.

ADDITIONAL ITEMS

- #21526 Tungsten Grinder Replacement Wheel
- #20177 3/32" x 7" E3 Purple Tungsten Rods, 2Pk.
- #20176 1/16" x 7" E3 Purple Tungsten Rods, 2Pk.

If you have any questions about the use of this product, please contact

The Eastwood Technical Assistance Service Department: 800.343.9353 >> email: techelp@eastwood.com

PDF version of this manual is available at eastwood.com

The Eastwood Company 263 Shoemaker Road, Pottstown, PA 19464 800.343.9353 eastwood.com