

*Eastwood*<sup>®</sup>

DO THE JOB RIGHT.<sup>®</sup>

Part #21561

# 14" DRY CUT METAL SAW

## INSTRUCTIONS

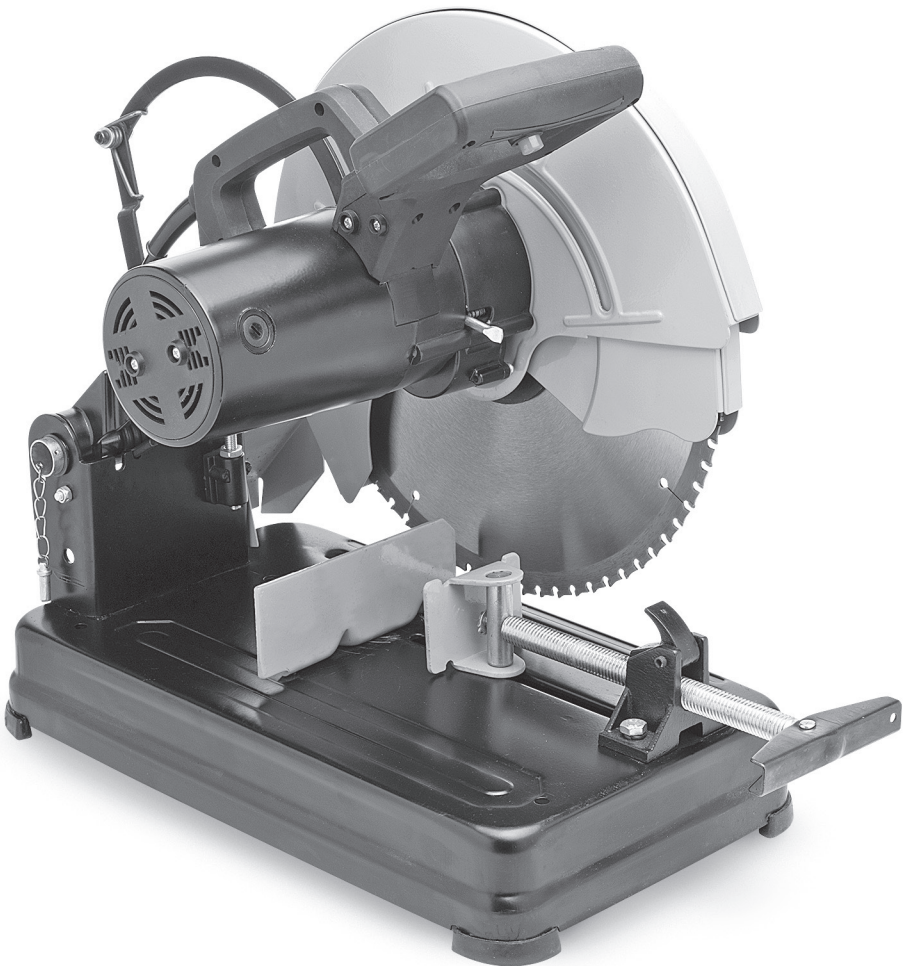

Your **EASTWOOD #21561 14" DRY CUT SAW** was designed with a powerful 15-amp motor and precision cut reduction gearing for maximum cutting torque when needed. It features a quick-release material clamp with tool-free angle adjustment, quick-removal blade cover and a positive spindle lock for fast blade changes.

## INCLUDES

- (1) Saw Assembly with Motor and Blade

## SPECIFICATIONS

- 120 VAC, 15 Amp motor
- 6' [1.8 m] long, 14 Gauge, 3 conductor grounded power cord
- 14" Outside Diameter [355mm] x 1" Arbor [25.4mm] x 3/32" [3.0mm] 1800 RPM maximum rated cutting blade (72-tooth Tungsten Carbide tipped blade)
- Maximum cutting range @ 90° setting with  
***Stop Fence adjusted to maximum width*** = 9.13" wide x 4.5" high
- Maximum cutting range @ 45° setting with  
***Stop Fence adjusted to maximum width*** = 6.25" wide x 3.13" high

## TOOLS REQUIRED (not included)

- 17mm wrench
- Two 14mm Wrenches
- 10mm Wrench
- Angle Protractor
- Square

# IMPORTANT SAFETY INFORMATION

The following explanations are displayed in this manual, on the labeling, and on all other information provided with this product:

## DANGER

DANGER indicates a hazardous situation which, if not avoided, will result in death or serious injury.

## WARNING

WARNING indicates a hazardous situation which, if not avoided, could result in death or serious injury.

## CAUTION

CAUTION used with the safety alert symbol, indicates a hazardous situation which, if not avoided, could result in minor or moderate injury.

## NOTICE

NOTICE is used to address practices not related to personal injury.

## GENERAL SAFETY RULES

### WARNING

Read all instructions. Failure to follow all instructions listed below may result in electric shock, fire and/or serious injury. The term "power tool" in all of the warnings listed below refers to your mains-operated (corded) power tool or battery-operated (cordless) power tool.

## SAVE THESE INSTRUCTIONS

### 1) ELECTRICAL SAFETY

- a) Power tool plugs must match the outlet. Never modify the plug in any way. Do not use any adapter plugs with earthed (grounded) power tools. Unmodified plugs and matching outlets will reduce risk of electric shock.
- b) Avoid body contact with earthed or grounded surfaces such as pipes, radiators, ranges and refrigerators. There is an increased risk of electric shock if your body is earthed or grounded.
- c) Do not expose power tools to rain or wet conditions. Water entering a power tool will increase the risk of electric shock.
- d) Do not abuse the cord. Never use the cord for carrying, pulling or unplugging the power tool. Keep cord away from heat, oil, sharp edges or moving parts. Damaged or entangled cords increase the risk of electric shock.
- e) When operating a power tool outdoors, use an extension cord suitable for outdoor use. Use of a cord suitable for outdoor use reduces the risk of electric shock.

## 2) PERSONAL SAFETY

- a) Stay alert, watch what you are doing and use common sense when operating a power tool. Do not use a power tool while you are tired or under the influence of drugs, alcohol or medication. A moment of inattention while operating power tools may result in serious personal injury.
- b) Use safety equipment. Always wear eye protection. Safety equipment such as dust mask, non-skid safety shoes, hard hat, or hearing protection used for appropriate conditions will reduce personal injuries.
- c) Avoid accidental starting. Ensure the switch is in the off-position before plugging in. Carrying power tools with your finger on the switch or plugging in power tools that have the switch on invites accidents.
- d) Remove any adjusting key or wrench before turning the power tool on. A wrench or a key left attached to a rotating part of the power tool may result in personal injury.
- e) Do not overreach. Keep proper footing and balance at all times. This enables better control of the power tool in unexpected situations.
- f) Dress properly. Do not wear loose clothing or jewelry. Keep your hair, clothing and gloves away from moving parts. Loose clothes, jewelry or long hair can be caught in moving parts.
- g) If devices are provided for the connection of dust extraction and collection facilities, ensure these are connected and properly used. Use of these devices can reduce dust-related hazards.

## 3) POWER TOOL USE AND CARE

- a) Do not force the power tool. Use the correct power tool for your application. The correct power tool will do the job better and safer at the rate for which it was designed.
- b) Do not use the power tool if the switch does not turn it on and off. Any power tool that cannot be controlled with the switch is dangerous and must be repaired.
- c) Disconnect the plug from the power source and/or the battery pack from the power tool before making any adjustments, changing accessories, or storing power tools. Such preventive safety measures reduce the risk of starting the power tool accidentally.
- d) Store idle power tools out of the reach of children and do not allow persons unfamiliar with the power tool or these instructions to operate the power tool. Power tools are dangerous in the hands of untrained users.
- e) Maintain power tools. Check for misalignment or binding of moving parts, breakage of parts and any other condition that may affect the power tools operation. If damaged, have the power tool repaired before use. Many accidents are caused by poorly maintained power tools.
- f) Keep cutting tools sharp and clean. Properly maintained cutting tools with sharp cutting edges are less likely to bind and are easier to control.
- g) Use the power tool, accessories and tool bits etc., in accordance with these instructions and in the manner intended for the particular type of power tool, taking into account the working conditions and the work to be performed. Use of the power tool for operations different from those intended could result in a hazardous situation.

# ADDITIONAL SAFETY INFORMATION



## **⚠ WARNING HEALTH AND INJURY HAZARDS!**

- Dust and fine particles are generated while cutting which can contain hazardous or toxic substances. Breathing this dust can cause many serious respiratory health conditions. Always use NIOSH approved respiratory protection while using this Saw.
- This Saw will eject particles, dust and sparks at high velocity during operation. Wear approved eye and skin protection at all times while operating.
- Cutting with this Saw can generate excessive noise. Wear appropriate hearing protection while using.
- The rotating Blade of this Saw can quickly catch loose clothing, long hair or jewelry causing serious personal injury. Keep all loose clothing, long hair and jewelry away from operating Saw.
- This Saw can quickly start up when handling while plugged in to electrical supply causing serious personal injury. Always unplug the tool from the electrical supply before changing Blade or performing maintenance.
- Sharp metal edges can cut. Always wear protective work gloves while handling.
- Rotating Saw Blades can quickly cut flesh. Keep hands and fingers away from rotating blade.
- This Saw can quickly and violently kick back while operating. Do not apply excessive force to Saw while in use. Always make sure the workpiece or material being cut is securely clamped or anchored.
- Damaged Saw Blades can shatter at high speed causing personal injury or property damage. If excessive vibration is felt, discontinue use immediately and disconnect tool from electrical supply. Inspect Blade and Saw components for damage. Do not resume use until resolution is found.

## **⚠ CAUTION FIRE HAZARD!**

- This Saw will eject a trail of sparks at high speed which can ignite flammable materials or injure others nearby. Do not operate in the vicinity of flammable materials and keep all persons and pets away from the work area.

# ADJUSTMENTS

## **⚠ WARNING**

**Unplug Saw from electrical supply before making any adjustments.**

### **STOP FENCE ANGLE**

The Stop Fence features a built-in degree scale to allow angled cuts up to 45° in both directions (**FIG 1**). To do so:

- Slightly loosen both retaining bolts of the Stop Fence with a 17mm wrench (not included).
- Carefully align the selected engraved degree mark on the Stop Fence with the engraved reference line on the Saw Base (**FIG 1**).

**NOTE:** For the greatest accuracy of cut angle, the use of a protractor (not included) or machinists square is highly recommended.

- Before tightening the retaining bolts, place a protractor (not included) or square (not included) against the Stop Fence and face of the Blade for an accurate reading then tighten the retaining bolts (**FIGS 2 & 3**).

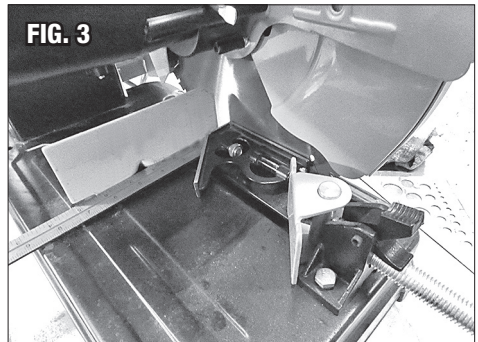
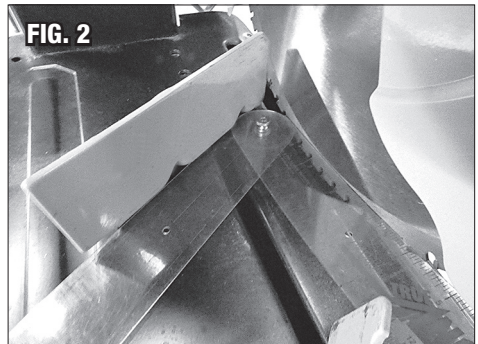
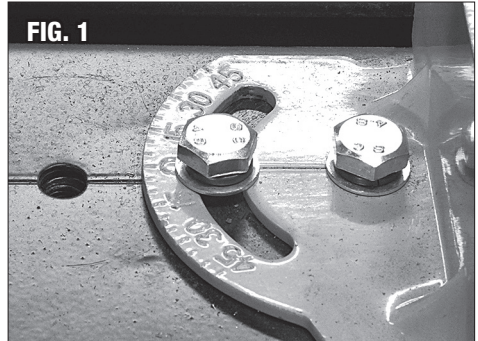



## STOP FENCE POSITION

The Stop Fence is designed with three mounting positions on the Saw Base. It may be moved back in two additional positions to allow for cutting wider materials. It is factory assembled with the Stop Face located nearest the centerline of the blade. To do so:

- Remove both retaining bolts of the Stop Fence with a 17mm wrench (not included).
- Move the Stop Fence to align with one of the two additional positions on the Saw Base (**FIGS 4 & 5**).
- Replace bolts and tighten.

## BLADE DEPTH

If the Blade does not cut all the way through the workpiece, the Depth Stop may need adjustment. To do so, follow Depth Stop Adjustment Procedure:

- Release the Trigger and raise the saw. Wait until the motor comes to a complete stop.
- Unplug the Saw.
- Remove the workpiece.
- Loosen the Lock-nut on the Depth Stop Bolt as shown in (**FIG 6**) using a 14mm wrench (not included).
- Turn the Depth Stop Bolt with a 14mm wrench (not included) to change the cutting depth. Raising it will decrease the cutting depth while lowering it will increase the cutting depth.

**NOTE:** For a proper depth setting, the Blade should protrude only slightly below the edge of the slot in the Saw Base. Under no circumstances should the Saw Blade ever contact the Saw Base or underlying surface.

- Following adjustment, re-tighten the Lock-nut on the Depth Stop Bolt securely against the Saw Base with a 14mm wrench (not included).

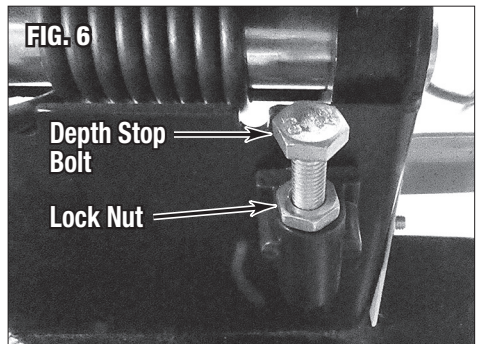
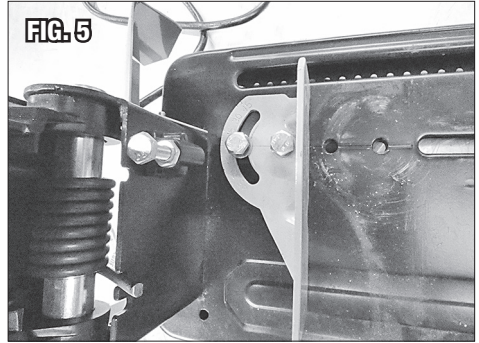
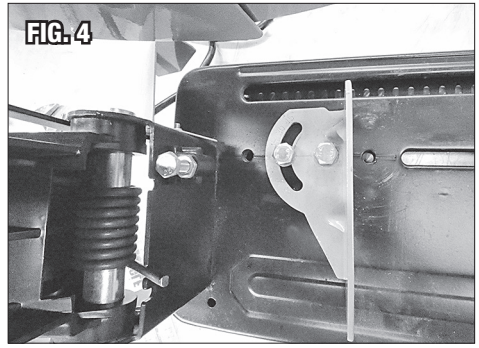

# SET UP FOR USE

- Place the Saw on a clean, dust and grit free surface. The rubber feet of the Saw Base are designed to assist with stability during normal operation, however it is strongly recommended that the machine be placed on a solid floor, away from any combustible materials due to the high-velocity ejection of sparks and high vibration levels while cutting. If machine is to be operated on a bench, it should be placed securely to prevent any chance of it working its way to the edge and falling.
- Keep power cord away from and out from under the Metal Cutting Saw blade. The unit is equipped with a 6' [1.8 m] long, grounded, 14 ga. power cord. Plug into a properly grounded, 20 Amp outlet. If an extension cord is required, use 14 ga. or heavier. Do not exceed 25'.
- **DO NOT OVERLOAD.** Saw is designed to accommodate Maximum material cutting range @ 90° setting with **Stop Fence adjusted to maximum width** = 9.13" wide x 4.5" high. Maximum cutting range @ 45° setting with **Stop Fence adjusted to maximum width** = 6.25" wide x 3.13" high. Attempts to cut over-sized material can result in serious personal injury, death and or serious damage to the saw.
- Be sure to support any materials being cut that extend beyond the base of the saw with equal height (3") blocks of wood or other suitable material.
- Secure loose work pieces by using the Material Clamp to prevent movement while cutting:

- To use the Quick Release, rock the Quick Release tab forward to engage the threads (**FIG 7**). Then tighten the Clamp Handle by rotating in a clockwise direction. When releasing, loosen the Clamp Handle a few turns to relieve clamping pressure, rotate the Quick Release tab rearward to disengage threads, and pull the Clamp Handle rearward to open (**FIG 8**).

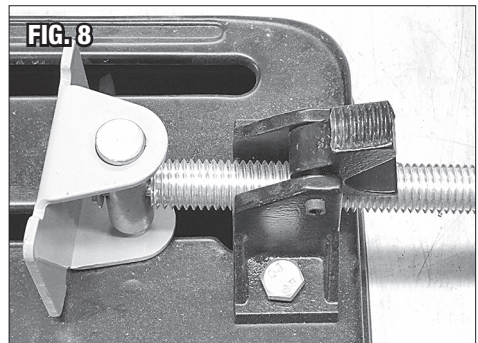
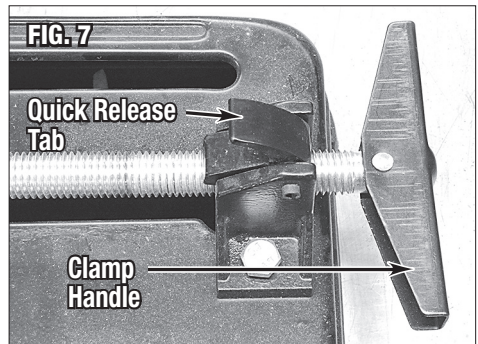



# OPERATION

- Adjust the Stop Fence to the desired angle of the cut. Always verify with a square for 90° or protractor for other angles.
- Using the Material Clamp, secure the workpiece and, if necessary, adjust the angle of the cut.
- Raise the Saw by pushing down on it and pulling out the Locking Pin located at the lower left side of the motor mount, just below the pivot (**FIGS 9 & 10**).
- Plug the Power Cord into the nearest 120 V~, grounded, 20 Amp electrical outlet. Be sure the power cord is away from and out from under the Chop Saw blade. Push in the Trigger Safety Lock Button (**FIG 11**) on the underside of the handle and pull on the Trigger (**FIG 11**) to run the Saw motor. Allow the Blade to reach full operating speed.
- With one hand on the Handle and the other hand kept away from the Saw, slowly lower the Saw down onto the Base, letting the Saw Blade do the cutting. **DO NOT** apply excessive force or serious personal injury, death and or serious damage to the saw can occur.

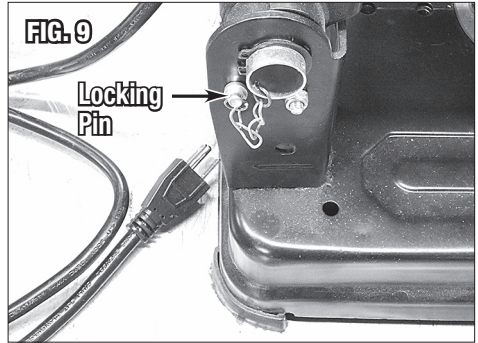

## **⚠ NOTICE**

**Keep your body and any objects out of the path of the sparks which will be ejected at high velocity from the rear of the saw!**



# BLADE REPLACEMENT

## **⚠ WARNING**

**Unplug Saw from electrical supply before changing blade!**

- Unplug the Saw.
- Raise the Saw by pushing down on it and pulling out the Locking Pin located at the lower left side of the motor mount, just below the pivot (FIGS 9 & 10).
- Move the Shaft Guard Plate out of the way by loosening the two 10 mm retaining nuts and rotating it up out of the way (FIGS 12 & 13).
- Retract the lower half of the Blade Safety Guard against spring pressure, up and fully into the upper half of the Safety Guard. This will expose a hole that the Armature Lock Pin must fit through before passing through, contacting and locking the motor armature (FIG 14).
- Continue to push the Armature Lock Pin lever located on the underside of the motor (FIG 15), inward towards the Blade while rotating the Blade slowly until the Lock Pin snaps into a detent locking the motor armature and preventing it from rotating.

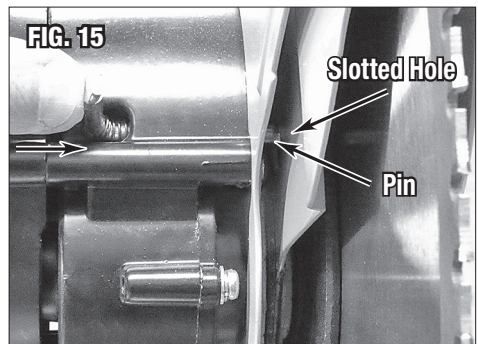
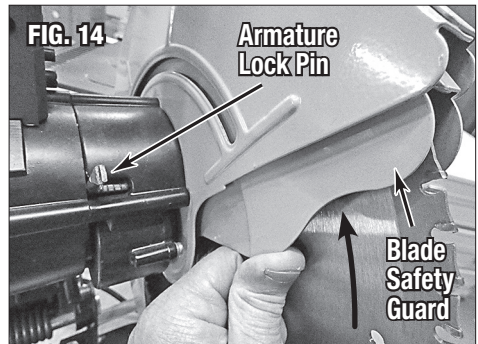
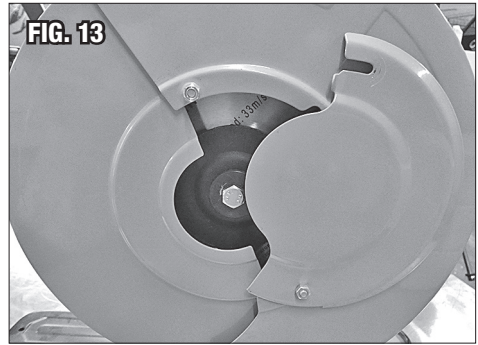
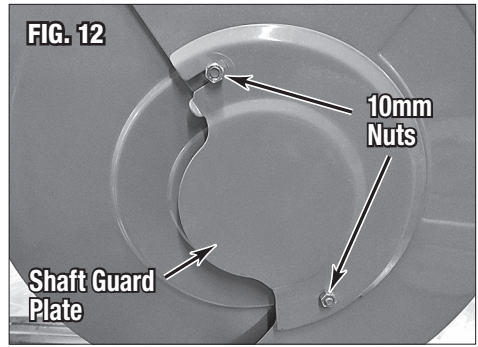

- While continuing to hold in the Armature Lock Pin, use a 17mm wrench (not included) to loosen the Blade Retaining Bolt (FIG 16).
- Remove and set aside the Blade Retaining Bolt and Large Washer (FIG 17).
- Remove Blade from Arbor.
- Replace the blade over the arbor followed by the Large Washer with the cupped side against the blade and finally the Blade Retaining Bolt.
- NOTE:** Be sure the flats of the Large Washer are aligned with the flats of the motor shaft (FIG 18).
- Keeping the Armature Lock Pin engaged, tighten the Blade Retaining Bolt securely with a 17 mm wrench (not included) (FIG 19).
- Gently release the Blade Safety Guard and allow the Armature Lock Pin to snap back to the released position.
- Rotate the Shaft Guard Plate back into place and tighten the two 10 mm nuts.
- Check blade depth and if necessary, adjust per Depth Stop Adjustment Procedure outlined under “ADJUSTMENTS” in these instructions.

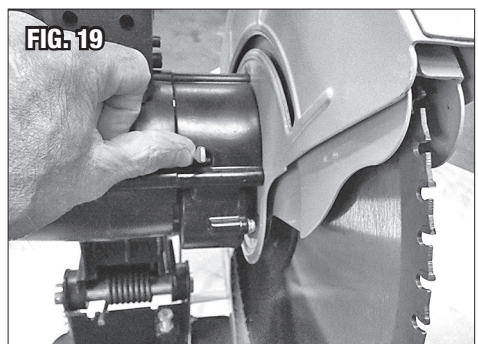
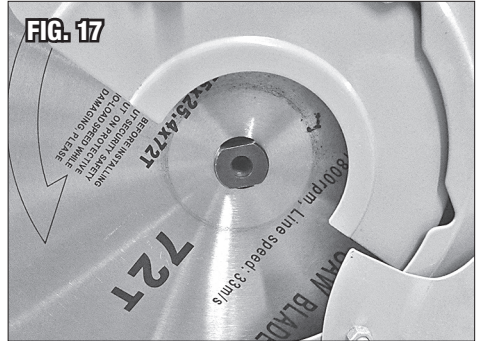
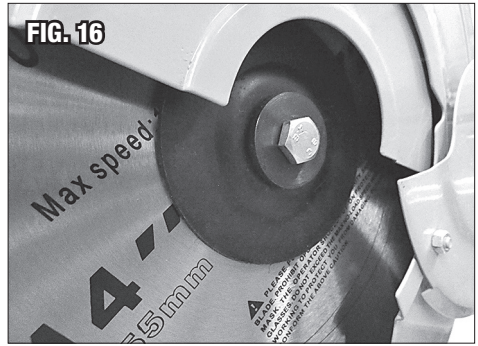

## STORAGE

- Unplug from power source.
- Lower Saw to cutting position and reinsert the Locking Pin located at the lower left side of the motor mount, just below the pivot (FIG 9).
- Wrap cord securely around Saw.
- Transport by using the built-in carry handle at the top of the motor housing.
- Store in a clean, dry, dampness free area preferably covered with plastic sheeting.

# MAINTENANCE

**IMPORTANT NOTE:** The following maintenance should be performed before each use:

- Check tightness of all hardware.
- Check operation and alignment of all guards.
- Inspect Blade for cracks, damage or premature wear.
- Clean dirt and debris from Saw base and motor air cooling slots.



# TROUBLESHOOTING

| PROBLEM  | CAUSE  | CORRECTION   |
|--|--|--|
| <b>Does Not Run When Switch is Turned On</b>           | No Power to Saw  | Check 120 VAC input plug connection.   |
|  |  | Check for tripped circuit breaker. The Saw operates on a 15 Amp Minimum circuit, 20 Amp is strongly recommended.                               |
| <b>Motor Runs Too Slow/ Develops Low Power</b>         | Excessive Voltage Drop Due to Local Power Company Voltage Supply.                    | Use at another location or at a time when voltage is higher.   |
|  | Excessive Voltage Drop Due to Under-sized and/or Too Long of an Extension Cord Used. | Extension cords not recommended. If necessary, use only 14 Gauge or larger cord and limit length to 25'.                                       |
| <b>Blade Does Not Cut All The Way through Material</b> | Blade Worn   | Check blade tooth condition and replace per "BLADE REPLACEMENT" section in these instructions.   |
|  | Blade depth out of adjustment  | Check blade depth and if necessary, adjust per Depth Stop Adjustment Procedure outlined under the "ADJUSTMENTS" section in these instructions. |



# TROUBLESHOOTING

| PROBLEM                                    | CAUSE   | CORRECTION   |
|--|---|--|
| <p><b>Excessive Noise or Vibration</b></p> | <p>Blade likely cracked or damaged.<br/> <b>WARNING: This is an extremely unsafe condition!</b></p> | <p>Discontinue use and replace blade.</p>                  |
| <p><b>Motor Overheats</b></p>              | <p>Excessive Pressure Being Applied While Cutting</p>   | <p>Allow Blade to cut by rotation alone. Do not force.</p> |
|  | <p>Dirt and Cutting Debris Buildup in Motor Cooling Air Slots</p>                                   | <p>Use a brush or compressed air to remove debris.</p>     |

# ADDITIONAL ITEMS

**#21562** Replacement 14", 72 tooth, 1800 RPM blade

---

**If you have any questions about the use of this product, please contact**

The Eastwood Technical Assistance Service Department: 800.343.9353 >> email: [techelp@eastwood.com](mailto:techelp@eastwood.com)

PDF version of this manual is available at [eastwood.com](http://eastwood.com)

The Eastwood Company 263 Shoemaker Road, Pottstown, PA 19464, USA

800.343.9353 [eastwood.com](http://eastwood.com)