

*Eastwood*<sup>®</sup>

**DO THE JOB RIGHT.<sup>®</sup>**

Item #22965

# 36" MOTORIZED BEAD ROLLER

## INSTRUCTIONS

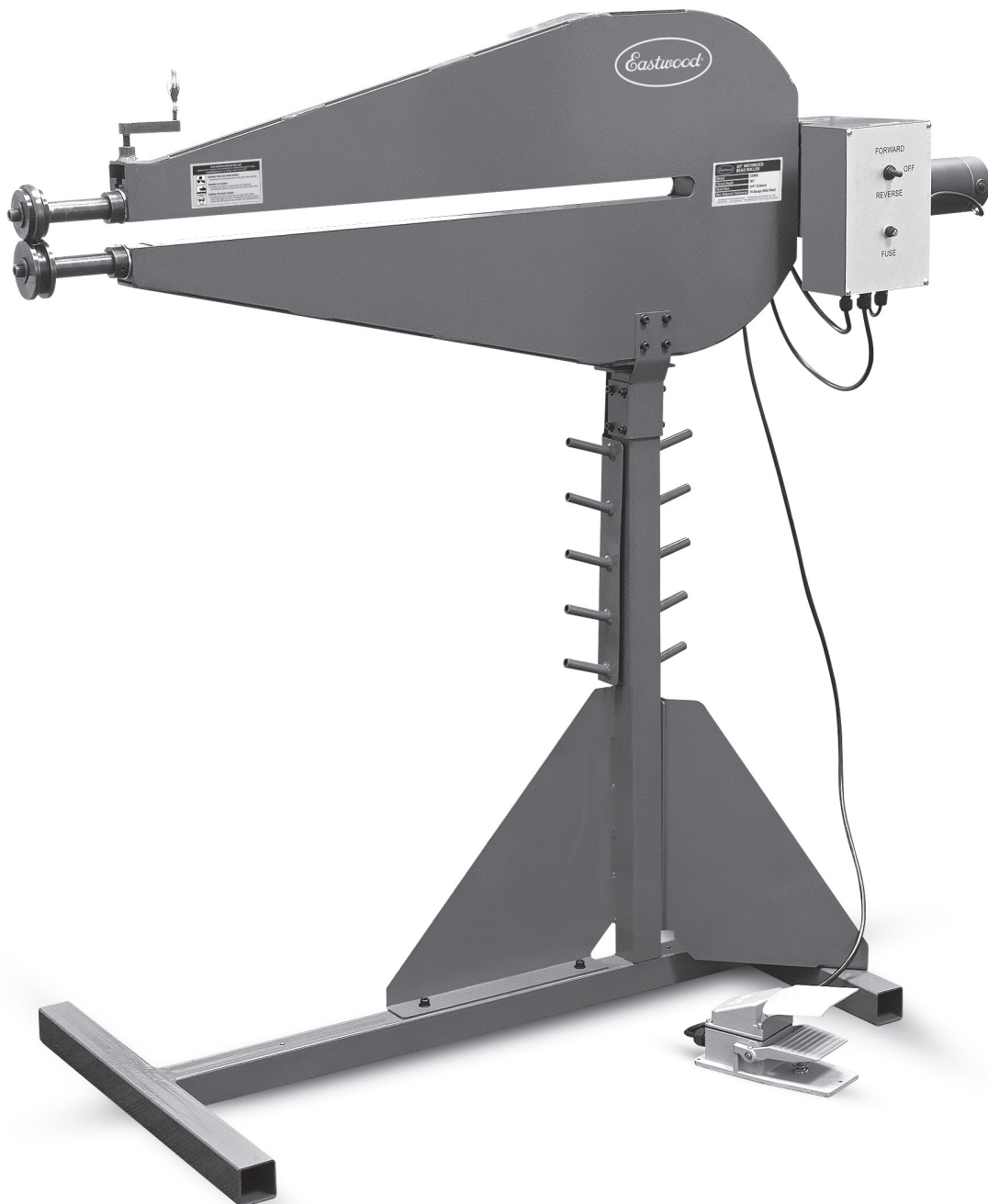

The **EASTWOOD 36" MOTORIZED BEAD ROLLER** is a professional metal fabrication tool which proves excellent for producing strengthening ribs in panels used in creating replacement floor pans, firewalls, trunk floors, inner fenders etc. and also for creating decorative custom designs in door panels, dashes and much more with the range of optionally available Dies. The motor-driven design delivers maximum forming power while providing a convenient foot-pedal control allowing 2 hands for panel handling. A generous 36" throat depth provides the ability to reach the center of a 6' panel.

## CONTENTS

### COMPONENTS

- (1) "H" Frame Base [A]
- (1) Upright Member with Gusset [B]
- (2) Wing Gussets [C]
- (1) 36" Bead Roller Head Assembly with Motor, Control Box, Wiring and Foot Pedal [D]
- (1) Head Assembly Brace [E]
- (1) Crank Handle [F]
- (1) Set of 1/2" Bead Dies (Pre-Installed) [G]
- (1) Die Holder Rack [H]

### HARDWARE

- (1) M12 x 55 mm Socket Head Cap Screw [J]
- (2) M10 x 20 mm Socket Head Cap Screws [K]
- (2) 10 mm Lockwashers [L]
- (6) M8 x 15 mm Socket Head Cap Screws [M]
- (6) 8 mm Lockwashers [N]
- (12) M6 x 10 mm Socket Head Cap Screws [P]
- (12) 6 mm Lockwashers [S]
- (2) M10 x 30 mm Socket Head Cap Screws (Pre-Installed w/Dies) [T]
- (2) 10 mm Flat Washers (Pre-Installed with Dies) [U]

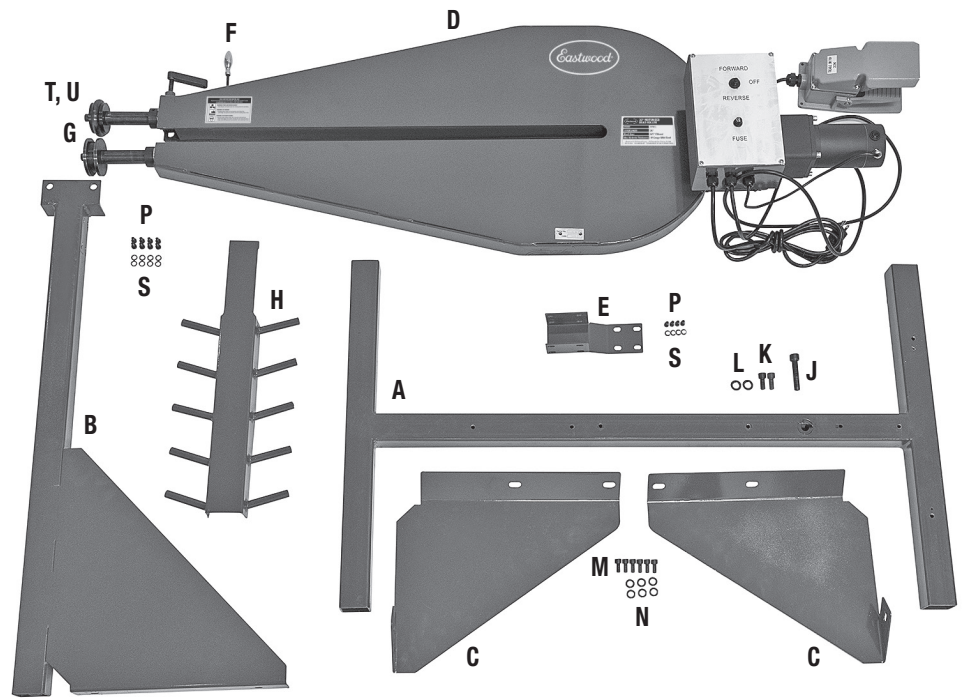

## SPECIFICATIONS

### Maximum material working thickness:

- Steel: 16 Gauge
- Aluminum: 14 Gauge

### Maximum panel width (working from center): 72"

120 VAC, 1.5 AMP motor with integral gear reduction

7-1/2' [2.3m], 18 Ga., 3 conductor with ground power cord



**LEARN HOW TO SET UP AND USE YOUR MOTORIZED BEAD ROLLER**

with FREE Instructional Videos Available at [eastwood.com](http://eastwood.com) – keyword search "22965"

# SAFETY INFORMATION

The following explanations are displayed in this manual, on the labeling, and on all other information provided with this product:

## **⚠ DANGER**

DANGER indicates a hazardous situation which, if not avoided, will result in death or serious injury.

## **⚠ WARNING**

WARNING indicates a hazardous situation which, if not avoided, could result in death or serious injury.

## **⚠ CAUTION**

CAUTION used with the safety alert symbol, indicates a hazardous situation which, if not avoided, could result in minor or moderate injury.

## **⚠ NOTICE**

NOTICE is used to address practices not related to personal injury.

# GENERAL SAFETY RULES

## **⚠ WARNING**

Read all instructions. Failure to follow all instructions listed below may result in electric shock, fire and/or serious injury.

The term “power tool” in all of the warnings listed below refers to your mains-operated (corded) power tool or battery-operated (cordless) power tool.

# SAVE THESE INSTRUCTIONS

## 1) WORK AREA SAFETY

- a) Keep work area clean and well lit. Cluttered or dark areas invite accidents.
- b) Do not operate power tools in explosive atmospheres, such as in the presence of flammable liquids, gases or dust. Power tools create sparks which may ignite the dust or fumes.
- c) Keep children and bystanders away while operating a power tool. Distractions can cause you to lose control.

## 2) ELECTRICAL SAFETY

- a) Power tool plugs must match the outlet. Never modify the plug in any way. Do not use any adapter plugs with earthed (grounded) power tools. Unmodified plugs and matching outlets will reduce risk of electric shock.
- b) Avoid body contact with earthed or grounded surfaces such as pipes, radiators, ranges and refrigerators. There is an increased risk of electric shock if your body is earthed or grounded.
- c) Do not expose power tools to rain or wet conditions. Water entering a power tool will increase the risk of electric shock.
- d) Do not abuse the cord. Never use the cord for carrying, pulling or unplugging the power tool. Keep cord away from heat, oil, sharp edges or moving parts. Damaged or entangled cords increase the risk of electric shock.
- e) When operating a power tool outdoors, use an extension cord suitable for outdoor use. Use of a cord suitable for outdoor use reduces the risk of electric shock.

### 3) PERSONAL SAFETY

- a) Stay alert, watch what you are doing and use common sense when operating a power tool. Do not use a power tool while you are tired or under the influence of drugs, alcohol or medication. A moment of inattention while operating power tools may result in serious personal injury.
- b) Use safety equipment. Always wear eye protection. Safety equipment such as dust mask, non-skid safety shoes, hard hat, or hearing protection used for appropriate conditions will reduce personal injuries.
- c) Avoid accidental starting. Ensure the switch is in the off-position before plugging in. Carrying power tools with your finger on the switch or plugging in power tools that have the switch on invites accidents.
- d) Remove any adjusting key or wrench before turning the power tool on. A wrench or a key left attached to a rotating part of the power tool may result in personal injury.
- e) Do not overreach. Keep proper footing and balance at all times. This enables better control of the power tool in unexpected situations.
- f) Dress properly. Do not wear loose clothing or jewelry. Keep your hair, clothing and gloves away from moving parts. Loose clothes, jewelry or long hair can be caught in moving parts.
- g) If devices are provided for the connection of dust extraction and collection facilities, ensure these are connected and properly used. Use of these devices can reduce dust-related hazards.

### 4) POWER TOOL USE AND CARE

- a) Do not force the power tool. Use the correct power tool for your application. The correct power tool will do the job better and safer at the rate for which it was designed.
- b) Do not use the power tool if the switch does not turn it on and off. Any power tool that cannot be controlled with the switch is dangerous and must be repaired.
- c) Disconnect the plug from the power source and/or the battery pack from the power tool before making any adjustments, changing accessories, or storing power tools. Such preventive safety measures reduce the risk of starting the power tool accidentally.
- d) Store idle power tools out of the reach of children and do not allow persons unfamiliar with the power tool or these instructions to operate the power tool. Power tools are dangerous in the hands of untrained users.
- e) Maintain power tools. Check for misalignment or binding of moving parts, breakage of parts and any other condition that may affect the power tools operation. If damaged, have the power tool repaired before use. Many accidents are caused by poorly maintained power tools.
- f) Keep cutting tools sharp and clean. Properly maintained cutting tools with sharp cutting edges are less likely to bind and are easier to control.
- g) Use the power tool, accessories and tool bits etc., in accordance with these instructions and in the manner intended for the particular type of power tool, taking into account the working conditions and the work to be performed. Use of the power tool for operations different from those intended could result in a hazardous situation.



**⚠ WARNING PINCH AND CRUSH HAZARD!**

- The Eastwood 36" Bead Roller consists of heavy metal components which can present a hand/finger pinch hazard and cause serious injuries if dropped. Avoid pinching hands while handling. The use of safety shoes is strongly recommended. Keep fingers and hands away from moving parts when operating.



**⚠ WARNING CUT HAZARD!**

- Handling sharp metal can cause serious cuts. Wear thick, well-fitting work gloves to prevent cuts from handling sharp metal.



**⚠ WARNING EYE INJURY HAZARD!**

- Metal particles can be ejected from the metal surface when bending. Sheet metal edges and corners are sharp and can injure eyes. Always wear ANSI approved eye protection when operating this tool.



**⚠ WARNING**

- Before beginning ANY work with this tool, it is absolutely necessary that it be located on a flat, stable and clean floor surface.
- Strenuous and awkward reaching may be required while operating the 36" Bead Roller. Failure to ensure proper footing can quickly result in a fall which could inflict serious personal injury or property damage. Always work in a clean, uncluttered environment. Be sure there is sufficient working room around the tool to allow for safe handling of various sizes of metal.



**⚠ NOTICE**

- Excessive resistance or motor strain while operating could indicate a defect with the workpiece material or broken or damaged Eastwood 36" Bead Roller components. To avoid injury, stop work immediately unplug unit and inspect workpiece material for nicks, dents, welds, excessive scale or remaining coatings. Clean or repair as necessary or discard and begin with a new piece. Also inspect the 36" Bead Roller components for looseness or damage.

# ASSEMBLY

## ⚠ NOTICE

The major component of the Eastwood 36" Bead Roller is the Head Assembly which is quite heavy and requires the assistance of a capable helper.

## ⚠ CAUTION INJURY HAZARD!

DO NOT attempt to lift the Bead Roller Head Assembly into place on the Base while alone. Obtain the assistance of a capable helper before beginning assembly.

- Set the "H" Frame Base [A] on a clean, flat floor surface (FIG 1).
- Place the Upright Member with Gusset [B] downward over the "H" Frame, align the two tapped holes and thread in (do not tighten) two M8 x 15 Screws [M] and 8mm Lockwashers [N] (FIG 1).
- Set the "H" Frame on its side and insert the M12 x 55 mm Screw [J] into the hole from the underside and into the tapped hole in the bottom of the Upright Member then securely tighten all hardware including the two previously added Screws (FIG 2).
- Return the "H" Frame to a flat on the floor position and add the two Wing Gussets [C] by securing with four M8 x 15 mm Socket Head Cap Screws [M] and Lockwashers [N] (FIG 3).

## ⚠ NOTICE

The following step requires the assistance of a capable helper.

- With the helper holding the Head Assembly in place and noting the offset configuration of the mounting tab atop the Upright Member, orient the Head Assembly with the Control Panel opposite the mounting tab, align the mounting holes with the two tapped holes of the Head Assembly and thread in the two M10 x 20 mm Socket Head Cap Screws [K] Lockwashers [L] and securely tighten (FIGS 4 & 5).

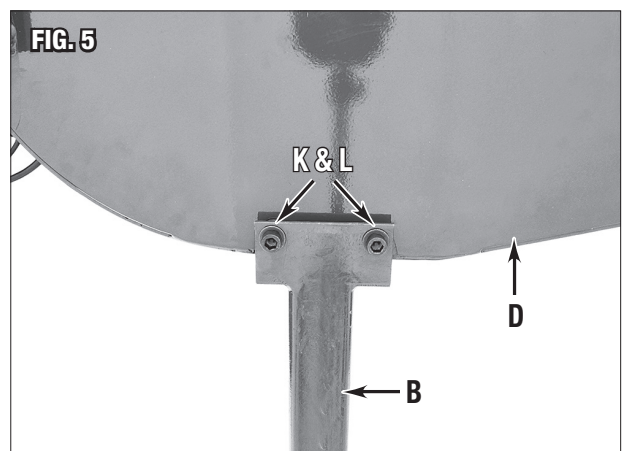
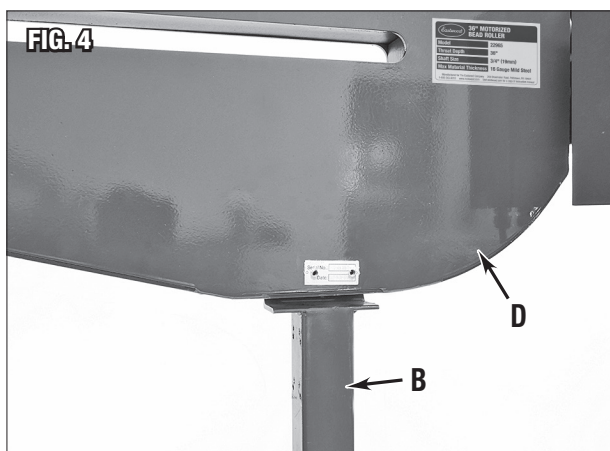
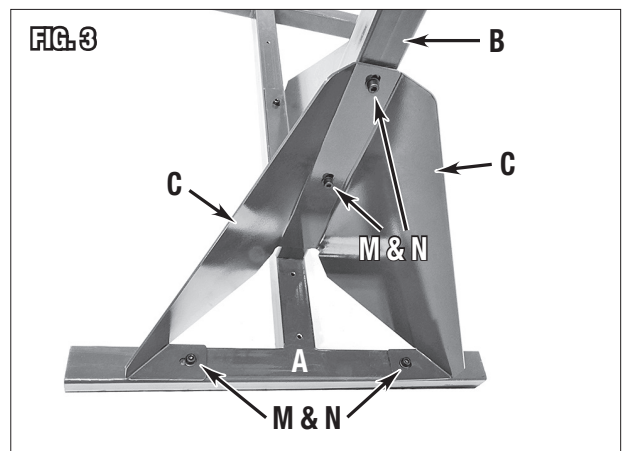
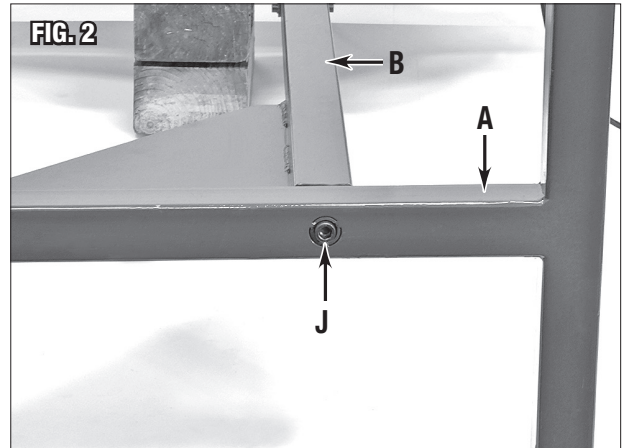
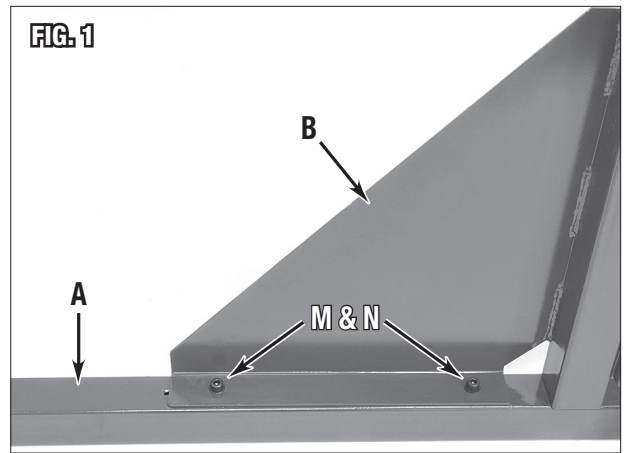

- Locate the Head Assembly Brace [E] at the joint of the Upright Member and Head Assembly (opposite side from the mounting tab) and secure with the twelve M6 x 10 mm Socket Head Cap Screws [P] and Lockwashers [S] (FIG 6).
- Next, thread the Crank Handle [F] into the Die Adjustment Crank (FIG 7).
- Lastly, install the Die Holder Rack [H] by hooking the lip at the top over the edge of the Head Assembly Brace [E] at the back of the Head Assembly (FIG 8).
- The Eastwood 36" Bead Roller is now ready for use.

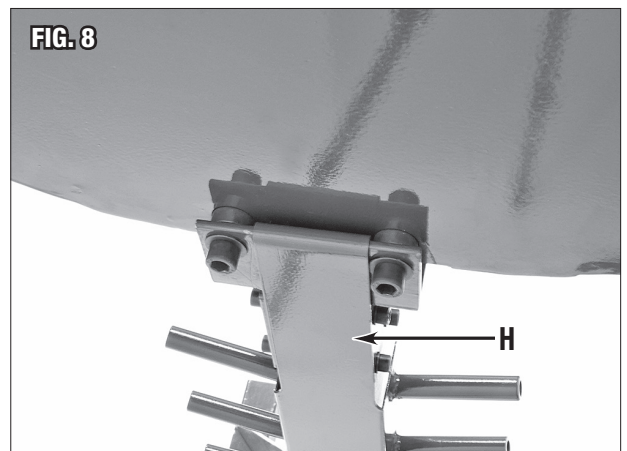
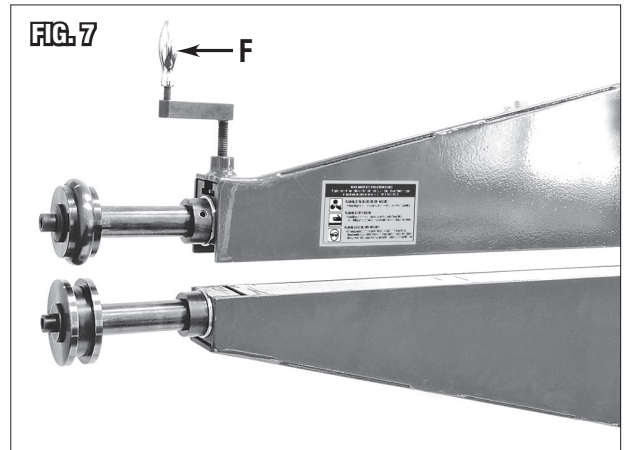
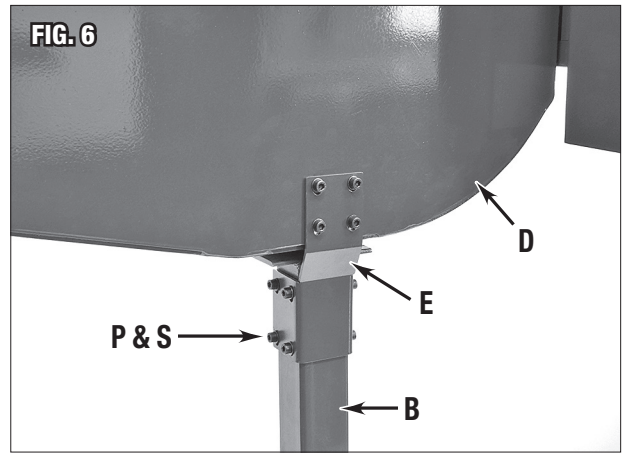

# OPERATION

## **⚠ CAUTION** PINCH HAZARD!

Keep the unit unplugged from the power supply while performing set-up and adjustment to avoid having fingers pinched between Dies.

## **⚠ NOTICE**

As with many professional metalworking tools, proficient operation of a Bead roller requires a learning curve. Eastwood strongly recommends practice on different gauges of steel and aluminum scrap metal before using on an actual project. This will help provide the user with the necessary skills to produce the best finished project results possible.

- Rotate the Die Tensioning Crank located at the top left of the Bead Roller Frame Counter-Clockwise several turns to raise the upper Die and Shaft and retract it (FIG 9).
- At this point, the Upper Die will be raised up sufficiently to separate the Bead Roller Dies enough to slide the workpiece metal between them.
- Center the Upper Die over planned path then lower the Upper Roller Shaft and Bearing Block down in place against the metal workpiece panel.
- Draw down the Die Tensioning Crank, check alignment with the planned bead line then tighten several additional turns.

## **⚠ NOTICE**

DO NOT over tighten as this may tear the metal workpiece, jam the Roller Dies or deform the Frame.

- Plug unit into power supply.
- Switch the Control Unit to FORWARD (FIG 10).
- Press down on Foot Pedal and move panel through rotating Dies.

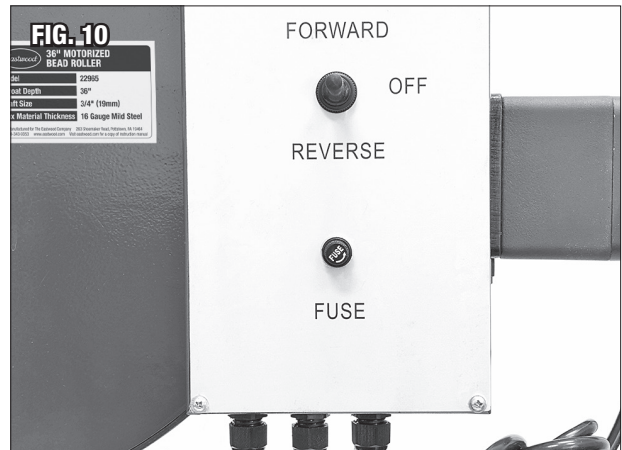
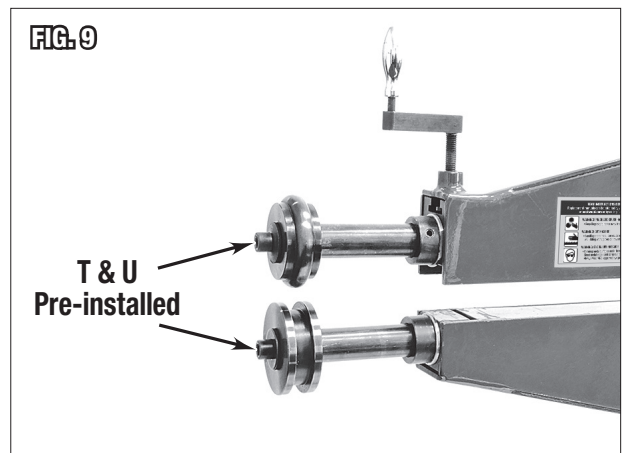

# LAYOUT & PLANNING

- Using a suitable marker, draw the desired pattern or shape to be formed directly on the panel. The use of a T-square and straightedge or long ruler for straight lines. For curves, use a circle or radius template.
- When forming beads, be sure to work from the inside of the piece toward the outside. The Dies shrink and draw metal while forming. If done from the outside toward the center, the bead previously formed will be distorted and the entire piece will likely warp.
- Before beginning a panel, carefully plan out how to most efficiently turn and move the panel while creating the pattern to avoid having to start and stop in the middle of a line.
- Additional planning time taken at this stage will make the rest of the job go that much more easily and help avoid mistakes.



## CREATING STRAIGHT BEADS

- Depress the Foot Pedal while moving the metal panel along following the pre-marked marked guideline.
- Keep the marked guideline aligned with the center of the Upper Die while forming is done. When reaching the end of the guideline, if a crisper profile is desired, the bead may be re-rolled. This done by stopping the motor, moving the Switch to REVERSE then re-tracing the bead.
- Crank the Upper Die upward and pull the workpiece panel from between the dies.

## FORMING CURVES

- The trick to forming curves with the bead roller is careful coordination between actuating the Die motion with the Foot Pedal, moving the metal workpiece slowly through the dies while turning it through the marked-out curve all at the same time. This procedure is an acquired skill and requires practice to master.
- It is critical to producing a good job that guideline be kept aligned with the center of the Upper Die progress is made. If the planned design forms an oval, start the bead in the center of a straight or larger radiused section.
- Do no attempt to start right at a corner or a joint of two lines, since it will be extremely difficult to line up the bead perfectly when bead is completed.
- By using combinations of curves and straight lines, there is almost no limit to the designs that can be created with the Eastwood Bead Roller.

## CHANGING DIES

### **CAUTION: PINCH HAZARD!**

**Keep the unit unplugged from the power supply while performing set-up and adjustment to avoid having fingers pinched between Dies.**

### **DIE REMOVAL**

- Loosen the Roller Tensioning, crank located at the top of the Bead Roller Frame.
- Raise the Upper Shaft and Die by continuing to rotate the Crank Clockwise.
- Loosen the Die Retaining Screws and Washers
- Pull the Dies from the shafts.

### **DIE INSTALLATION**

- With the Upper Shaft in the up position, slide the Dies onto the shaft ends. Note that the Male Die should always be on the upper shaft while the Female Die should be on the lower.
- Use care to align the machined grooves or offsets of the Dies before tightening screws.
- Re-adjust the Roller Tensioning.

# STORAGE

- Unplug unit from the power supply.
- Apply a thin film of light oil or rust-preventive to all bare steel areas.
- Store in a clean, dust-free, dry, dampness free area preferably covered with plastic sheeting.

# MAINTENANCE

## FUSE REPLACEMENT

- Unplug unit from power supply.
- Unthread Fuse Cap from front of Control Panel and remove fuse.
- Check fuse condition and replace if necessary, with an F15 AL, 15 AMP Fuse.
- Re-install Fuse Cap.

**NOTE:** The following maintenance should be performed before each use.

- Clean dirt and debris from Dies.
- Check tightness of all hardware.
- Check operation for binding. Lubricate bearings periodically with a good quality motor oil.
- Add a thick bodied chassis grease to the drive gears.



# TROUBLESHOOTING

PROBLEM	CAUSE	CORRECTION
<b>Does Not Run When Switch is Turned On</b>	No power to Motor	Check 120 VAC input plug connection.
		Check for tripped circuit breaker. The Saw operates on a 15 Amp minimum circuit, 20 Amp is strongly recommended.
	Fuse may be burned	Check Fuse and replace with an F15 AL, 15 AMP Fuse.
<b>Motor Runs Too Slow/ Develops Low Power</b>	Excessive voltage drop due to local power company voltage supply	Use at another location or at a time when voltage is higher.
	Excessive voltage drop due to under-sized and or too long of an extension cord used	Extension cords not recommended. If necessary, use only 14 Gauge or heavier cord and limit length to 25'.
<b>Dies Do Not Produce a Crisp Bead in Material</b>	Die tension too loose	Check Die tension and increase if needed.
	Material too thick or too hard	Do not exceed 16-Gauge in mild steel or 14-gauge in aluminum. Not recommended for stainless and high carbon steel.
<b>Dies Cut Through Material</b>	Die tension too great	Reduce Die tension.
	Material too thin or too soft	Not recommended for thinner than 20-gauge mild steel or aluminum. Not recommended for copper or brass.

## ADDITIONAL ITEMS

- #51088 Shrinker/Stretch Set
- #13475 Eastwood Electric Metal Shears
- #11797 Throatless Shear
- #14042 Versa Bend Sheet Metal Brake
- #20254 Eastwood 24" Slip Roll
- #21284 Motorized Bead Roller Forming Dies
- #20628 Motorized Bead Roller Spoiler Roll, 1-1/4"
- #32549 Eastwood 1/2" Round Bead Roll Die Kit
- #32550 Eastwood 3/4" Round Bead Roll Die Kit
- #32551 Eastwood 1" Round Bead Roll Die Kit
- #32552 Eastwood 45 degree Step Roll Kit
- #32553 Eastwood Tipping Roll Kit
- #32554 Eastwood Rotary Shearing Die Set
- #32555 Eastwood Hem Roll Set Step 1
- #32556 Eastwood Hem Roll Set Step 2
- #32557 Eastwood Hem Roll Set Step 3
- #32558 Eastwood Tube Beading Die Set

**If you have any questions about the use of this product, please contact**

The Eastwood Technical Assistance Service Department: 800.343.9353 >> email: tech@eastwood.com

PDF version of this manual is available at eastwood.com

The Eastwood Company 263 Shoemaker Road, Pottstown, PA 19464, USA 800.343.9353 eastwood.com