

Eastwood

DO THE JOB RIGHT.

Part #25304

BRAKE TUBE FLARING TOOL

INSTRUCTIONS



This **Eastwood Brake Tube Flaring Tool** will pay for itself with the first project, and it will give you peace of mind knowing that your brake flares are of OE-precision, quality, and safety. The tool mounts in your vise to help you easily form 45-degree single, double, and bubble flares in OE steel, stainless steel, and soft metal tubing for 3/16", 1/4", 5/16", 3/8", and 4.75mm-diameter lines.

SAFETY

- Always wear eye protection when operating the Flaring Tool as oils, grease and metal particles may be ejected while the tool is in operation.
- Make sure that the Flaring tool is clamped securely in a vise, keep hands and fingers away from the mating tool faces.
- Wear gloves while operating this tool to avoid cuts from sharp metal edges.

CONTENTS

- (1) Vise Mounted Brake Flaring Tool
- (1) Rotating Die Head – Features “operation 1” and “operation 2” dies for 3/16", 1/4", 5/16", 3/8" and 4.75mm, 45 degree, double flares
- (4) Sets of Split Dies – for 3/16", 1/4", 5/16", 3/8" and 4.75mm
- (1) Lever Handle
- (1) Blow Molded Case

SET UP & OPERATION

PREPARING TUBING

1. Square cut the tube end. A suitable Tubing Cutter works well.
2. Chamfer the outside and ream inside of tubing and remove burrs. Be sure to clear metal chips from inside tubing.
3. Clean outside of tubing before placing into jaws.
4. Very lightly lubricate the end of the cut tubing with a dab of Anti-Seize Compound.
5. Place appropriate fittings over ends of tubing, with flare end facing outward.

TOOL SET UP AND OPERATION

1. Place 1-1/2" x 1-1/2" square offset base of tool (opposite the clamp) into a secure vise (Fig. 1).
2. Place Rotating Die Head onto 1-1/4" round boss (adjacent to lever base). Be sure to seat head fully and snap over ball detent on side (Fig. 2).

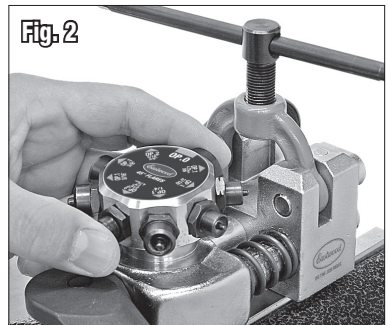
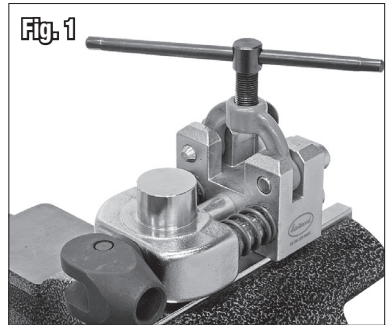

3. Place 11" foam-gripped handle into hole in lever base. Be sure to seat handle fully and snap groove into ball detent on side of hole.
4. Pull Clamp Pin (with black knob) out releasing clamp (Fig. 3).
5. Rotate clamp upward.
6. Choose the Split Die size that you need, insert the dies into the rectangular recess in the tool base with the beveled counterbore end (with sizes stamped) toward the Rotating Die Head and the back end firmly against the step (Fig. 4).
7. Place the tube between the die halves with the tube end flush with the flared end of the Dies. The Flat Faced OP.O die is a gauge used to line up the end of the tube flush with the Split Dies. Rotate Die Head so that the flat faced die OP.O is facing the end of the tube. Move lever inward toward body using the OP.O die as a stop gauge (Fig. 5).

NOTE: The tube end **MUST BE FLUSH** with the end of the die set to create a complete double flare (Fig. 6).

8. Rotate clamp back into place, push Clamp Pin through holes and back into the tool until the black knob seats against the body of the tool.

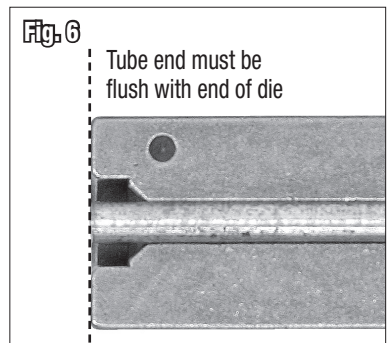
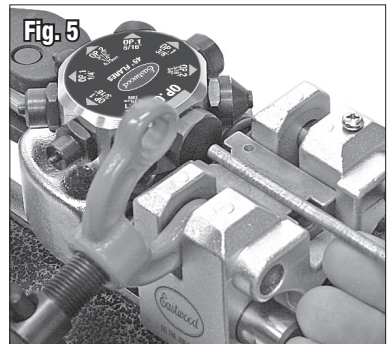
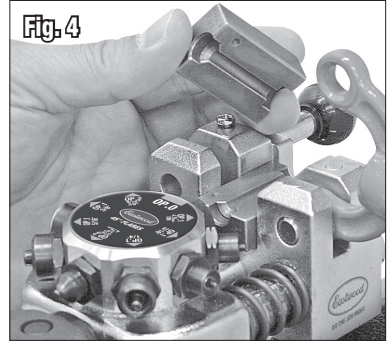
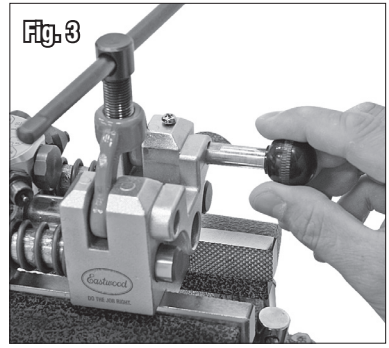

9. Tighten threaded retainer "T"-handle screw in clamp securely against the die set (Fig. 7).
10. Spin rotating Die Head with the appropriate size OP.1 Flaring Die lined up with the end of the tube (Fig. 8).
11. Move lever against tool body exerting sufficient effort to create flare, continuing until it stops (Fig. 9).

NOTE: at this point, a bubble flare has been created. To create a 45 degree double flare, continue with the following steps.

12. Spin rotating die head with one of the two appropriate sized OP.2 45 Degree Dies lined up with the end of the tube.
13. Move lever against tool body exerting sufficient effort to create the inverted portion of the double flare, continuing until it stops.
14. Loosen threaded retainer "T"-handle screw, pull the clamp retaining pin then remove the split dies.
15. Remove the finished flared tube from the dies. A slight tap may be required to release the tube from the dies.
16. You now have a finished, pro-quality, 45 degree double flare (Fig. 10).

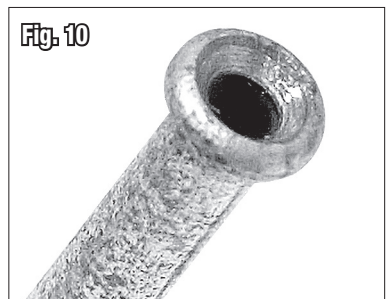
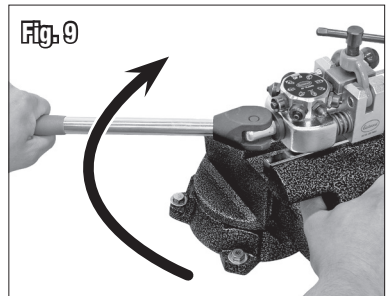
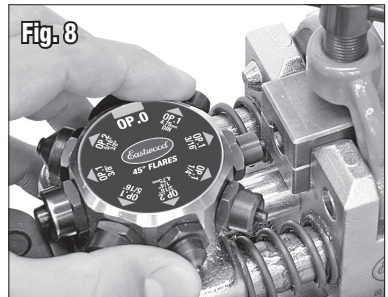
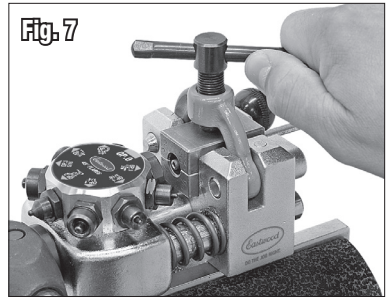

If you have any questions about the use of this product, please contact
 The Eastwood Technical Assistance Service Department: 800.544.5118 >> email: techhelp@eastwood.com
 PDF version of this manual is available online >> eastwood.com/25304manual
 The Eastwood Company 263 Shoemaker Road, Pottstown, PA 19464, USA
 US and Canada: 800.345.1178 Outside US: 610.718.8335
 Fax: 610.323.6268 eastwood.com