

*Eastwood*

DO THE JOB RIGHT.

Item #28187

# EASTWOOD BEAD ROLLER

## INSTRUCTIONS



The **Eastwood Bead Roller** is a professional metal fabrication tool for producing strengthening ribs in panels used in creating replacement floor pans, firewalls, trunk floors, inner fenders, etc. It can also be used for creating decorative custom designs in door panels, dashes, channels, flanges, and much more with the range of included beaded mandrels. The gear-driven design delivers maximum forming power while requiring minimal handle force for maximum accuracy.

## INCLUDES

- (1) 18" Throat Bead Roller Frame
- (1) Crank Handle
- (6) Complete Sets of Mandrel Dies
  - 1/16", 1/8" & 1/4" Flanging Mandrels
  - 1/4", 3/8" & 1/2" Bead Forming Mandrels

## SPECIFICATIONS

- Maximum material working thickness: Steel = 18 Gauge, Aluminum = 16 Gauge
- Maximum panel width (working from center) = 36"

## SAFETY INFORMATION

### **WARNING**

WARNING indicates a hazardous situation which, if not avoided, could result in death or serious injury.

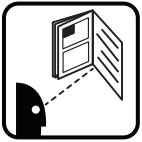

### **READ INSTRUCTIONS**

- Read the entire manual before setup and use.
- Keep this manual in a safe location as it will be necessary to refer to it often.



### **WARNING INJURY HAZARDS**

- This tool has rotating rollers and gears with amplified leverage which can quickly cause severe injury! Keep fingers and hands away from moving parts when operating.
- Wear work gloves and protective clothing. Sheet metal will often have sharp edges which can cause cuts to hands, arms and face.
- Frequently inspect moving parts and structure of the Bead Roller. If damage is observed, discontinue tool use immediately.
- Make sure the Bead Roller Frame is securely mounted in a minimum 4" (6" or larger, strongly recommended) vise properly fastened to a solid work surface before use. **IMPORTANT NOTE:** The Eastwood Bead Roller is moderately heavy, have a helper available when installing in the vise.
- Wear appropriate eye protection.



## SET UP

- Clamp the lower edge of the Bead Roller Frame in a minimum 4" (6" & larger strongly recommended) vise with the Roller Tensioning Bolt toward the top (**Fig A**), and tighten vice securely. Note: It is helpful to use a vise with a swiveling base, since you will be able to rotate it as needed to maintain a comfortable position while working a panel.
- Slip the 1" [25mm] broached hole in the Crank Handle over the large 1" [25mm] drive end of the Lower Shaft, align set screw with the flat on the shaft and tighten with a 10mm wrench (not included) (**Fig B**).

## LAYOUT & PLANNING

- Using a suitable marker, draw the pattern or shape you want to form with beads right on the panel. We recommend using a T-square and straightedge or long ruler for straight lines (**Fig C**). For curves, use a circle or radius template.
- Work carefully & lay out your design lines as neatly as possible.
- When forming beads, be sure to work from the inside of the piece toward the outside. The bead roller shrinks metal and if you work from the outside toward the center, the bead you previously formed will be distorted and the entire piece may warp.
- Plan out how you will need to turn and move the panel while creating the pattern to avoid having to start and stop in the middle of a line.
- A little time taken at this stage will make the rest of the job go that much more easily and help avoid mistakes.

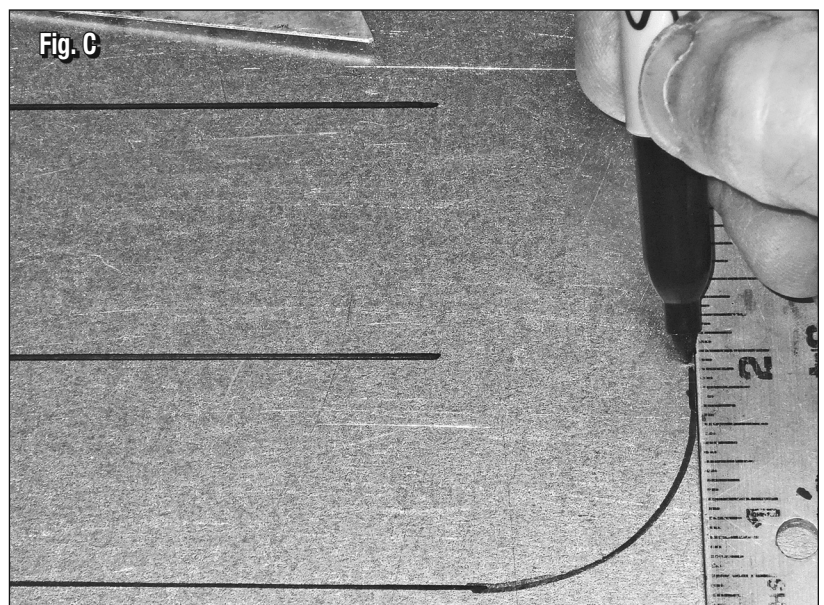
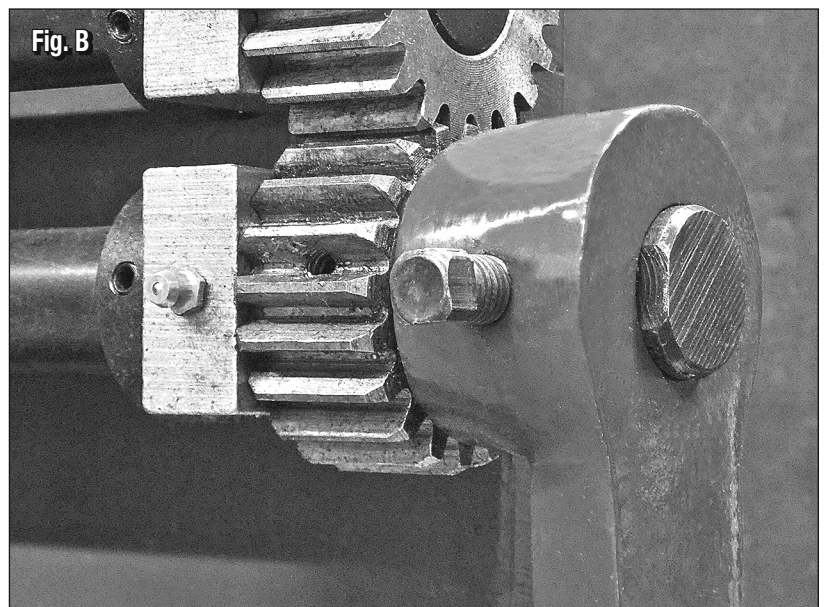
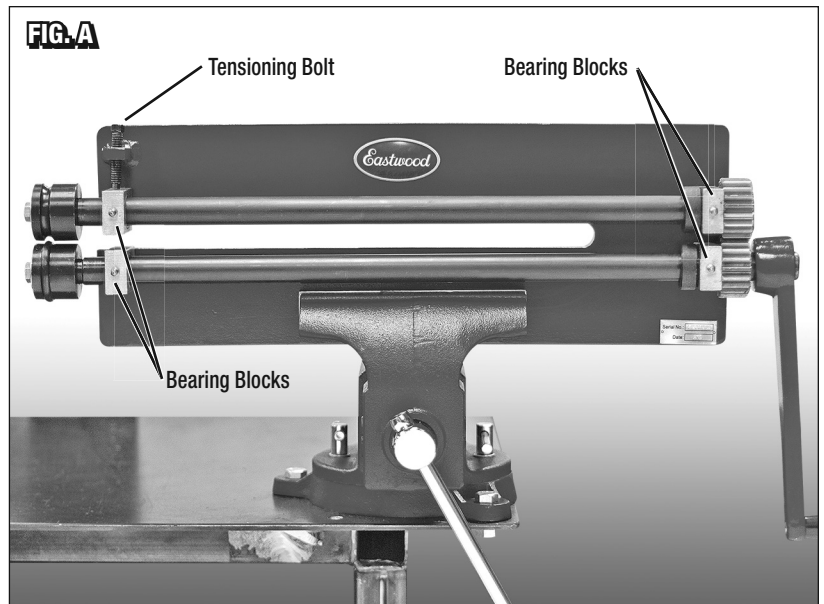

# OPERATION

## GETTING STARTED

- Loosen the 2 Upper Bearing Block bolts located at the rear of the Bead Roller Frame with a 19mm wrench (not included) (**Fig D**). Note that the Left upper Bearing Block mounting hole is slotted.
- Loosen the Roller Tensioning Bolt with a 10mm wrench (not included) and retract it several turns (**Fig E**). At this point, the Left side of the Upper Roller Shaft and Bearing Block should be free to be raised up sufficiently to separate the Bead roller Mandrels enough to slide the workpiece metal between them.
- Center the Upper Female Mandrel Die groove over the previously drawn pattern line then slide the Upper Roller Shaft and Bearing Block down in place against the metal workpiece panel (**Fig F**).
- Draw down the Roller Tensioning Bolt finger tight, check alignment with your drawn line then tighten several additional turns with a 10mm wrench (not included) (**Fig G**). Caution: Do Not Over tighten as this may tear the metal workpiece, jam the Roller Dies or deform the Frame.
- Tighten the Upper Bearing Block bolts located at the rear of the Bead Roller Frame with a 19mm wrench (not included) (**Fig H**).

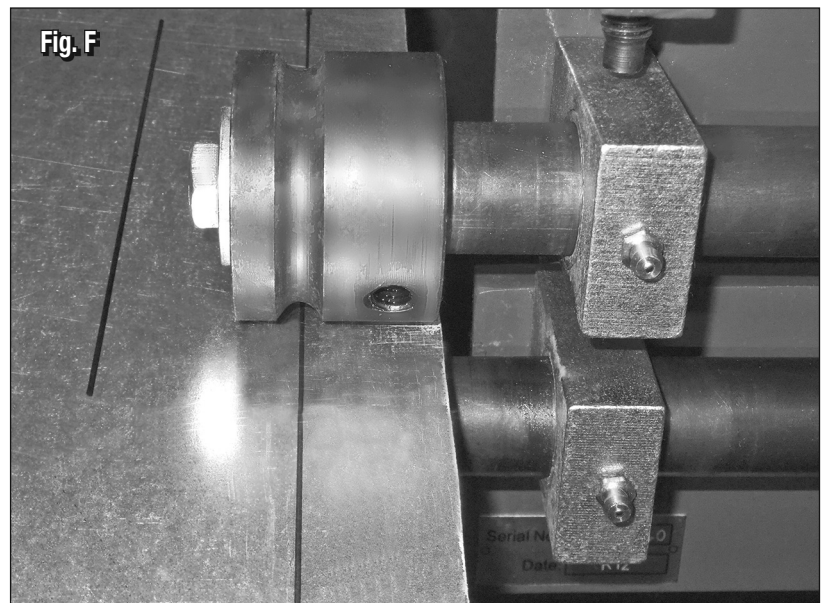
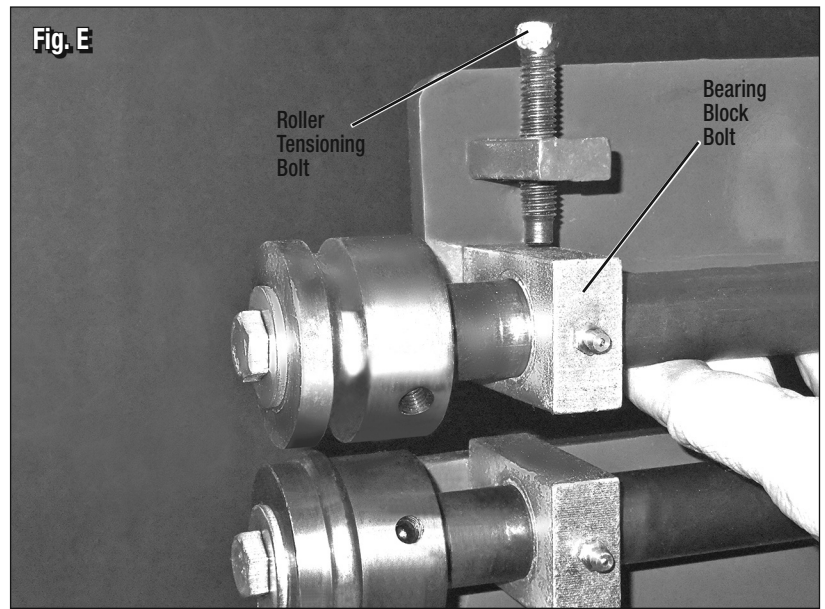
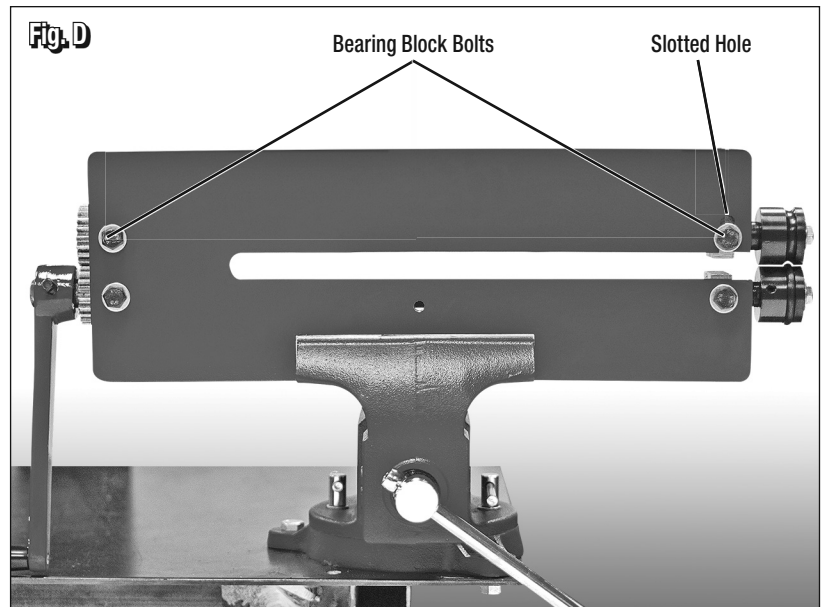

## CREATING STRAIGHT BEADS

**IMPORTANT NOTE:** For the greatest ease in handling workpiece panels and achieving optimal accuracy in forming beads, it is strongly advised to have a helper turn the handle as you work.

- Have the helper crank slowly as you move the metal along following your marked guideline (**Fig I**).
- Keep the marked guideline aligned with the center of the Upper Female Mandrel Die groove as you go. When you reach the end of the guideline, you may re-roll the bead by having your helper turn the crank in the opposite direction. This produces a more sharply defined bead.
- When done, loosen and retract the Roller Tensioning Bolt then loosen the Upper Bearing Block bolts located at the rear of the Bead Roller Frame with a 19mm wrench (not included).
- Pull the workpiece panel from between the dies and admire your work.

## FORMING CURVES

- The trick to forming curves with the bead roller is careful coordination between your helper cranking the handle, and you moving the metal workpiece slowly through the dies while turning it through the curve all at the same time.
- It is critical to producing a good job that you keep the guideline aligned with the center of the Upper Female Mandrel Die groove as you go (**Fig J**). If your design forms an oval, start the bead in the center of a straight or larger radiused section.
- Do no attempt to start right at a corner or a joint of two lines, since it will be extremely difficult to line up the bead perfectly when you finish.
- By using combinations of curves and straight lines, there is almost no limit to the designs you can create with the Eastwood Bead Roller.

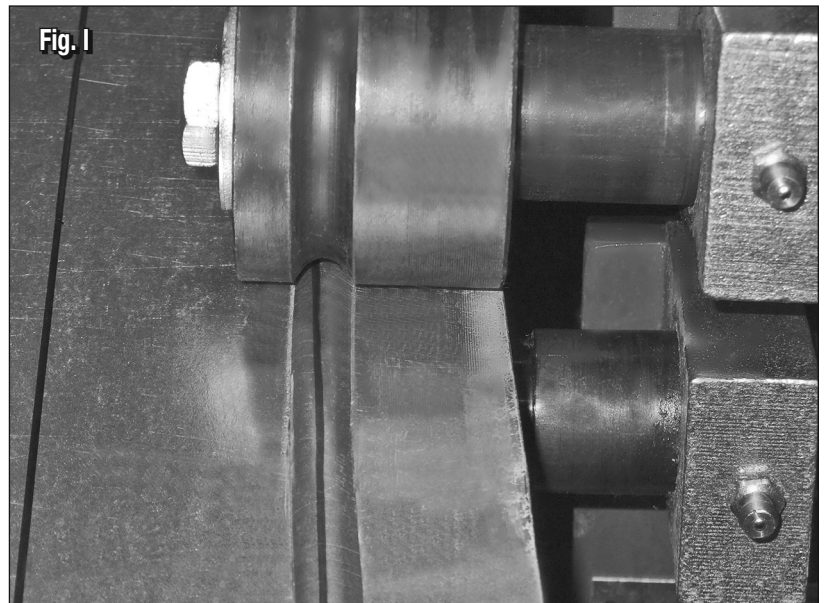
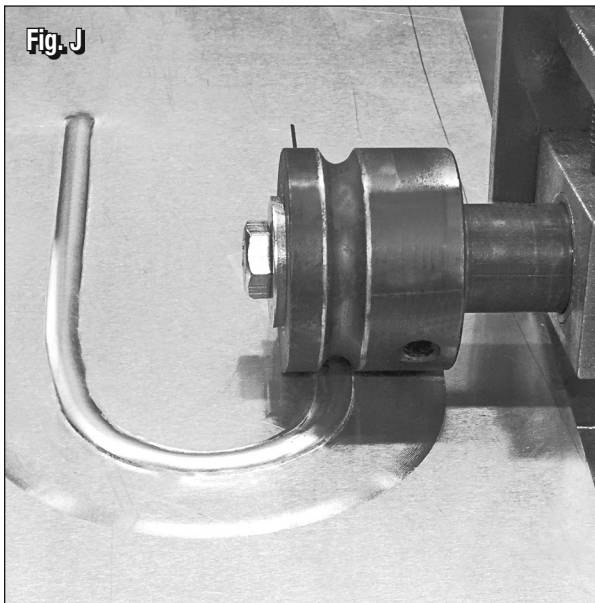
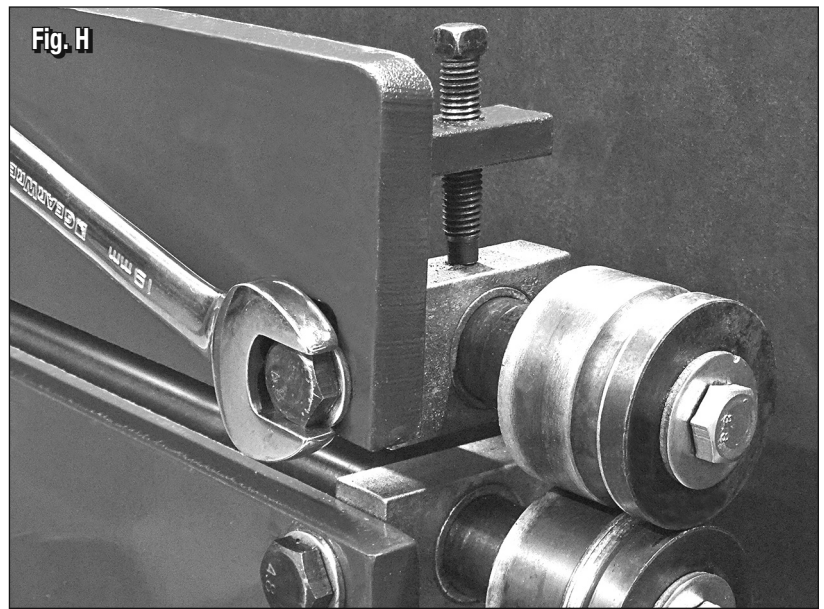
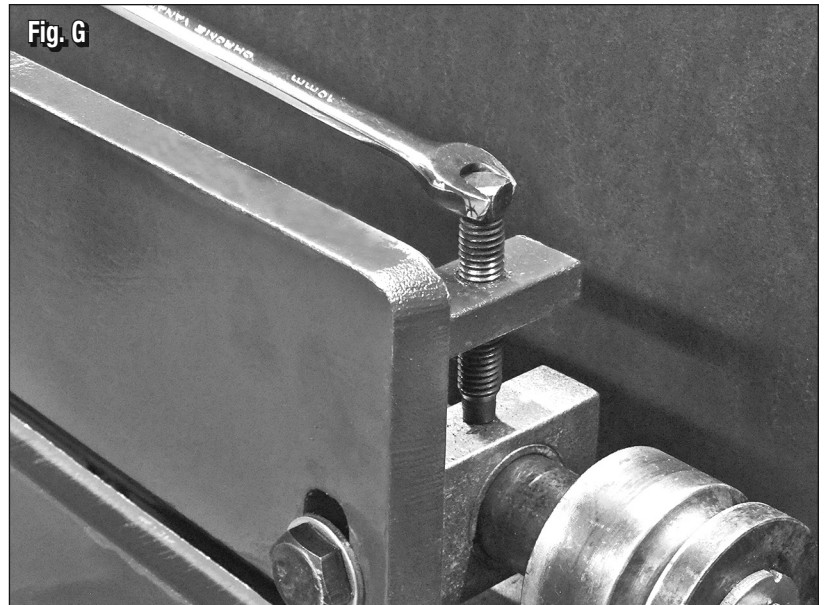

# CHANGING MANDREL DIES

## MANDREL DIE REMOVAL

- Loosen the 2 Upper Bearing Block bolts located at the rear of the Bead Roller Frame with a 19mm wrench (not included) (**Fig K**). Note that the Left upper Bearing Block mounting hole is slotted. Allow the upper Mandrel Die to rest on the lower one temporarily and with the drive gear teeth engaged, hold the Crank Handle to keep the shafts from turning then with a 16mm wrench, (not included) loosen and remove the (2) Mandrel Die Cap Screw Bolts. (**Fig L**).
- Loosen the 4mm Mandrel Die setscrews with a 4mm hex key (not included). (**Fig M**).
- Pull the Mandrel Dies from the shafts. (**Fig N**).

## MANDREL DIE INSTALLATION

- Raise the upper shaft slightly and slide the Mandrel Dies onto the shaft ends. Be sure to align the set screws with the flats of the shafts.
- Use care to align the machined grooves or offsets of the Mandrel Dies before tightening set screws.
- Re-install the Cap Screw Bolts and tighten with a 16mm wrench (not included).
- Adjust the 2 Upper Bearing Block Bolts and Roller Tensioning Bolt as required.

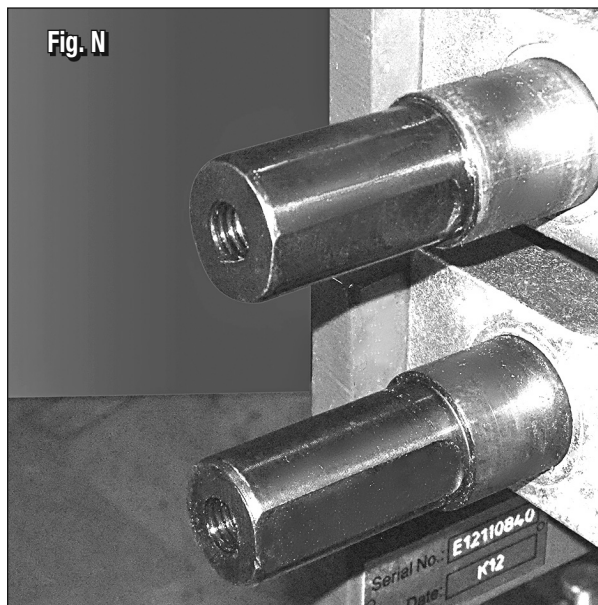
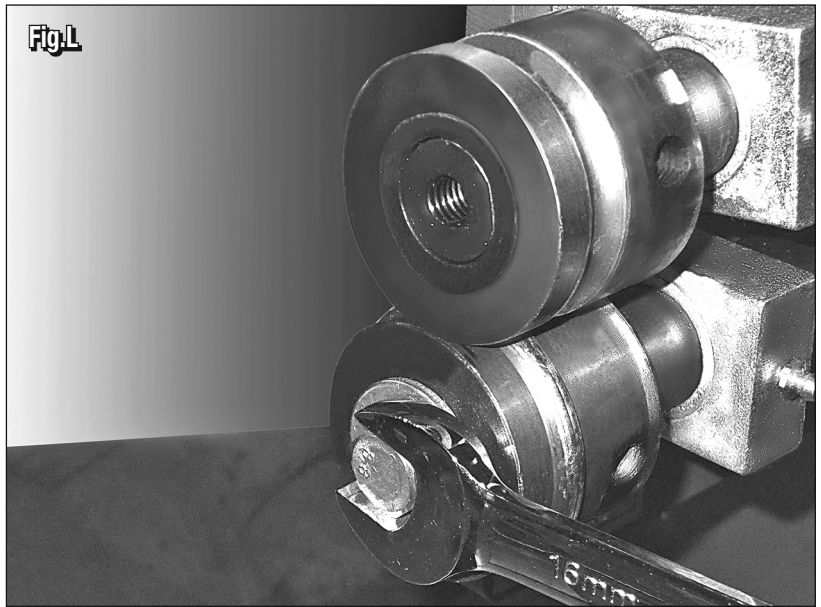
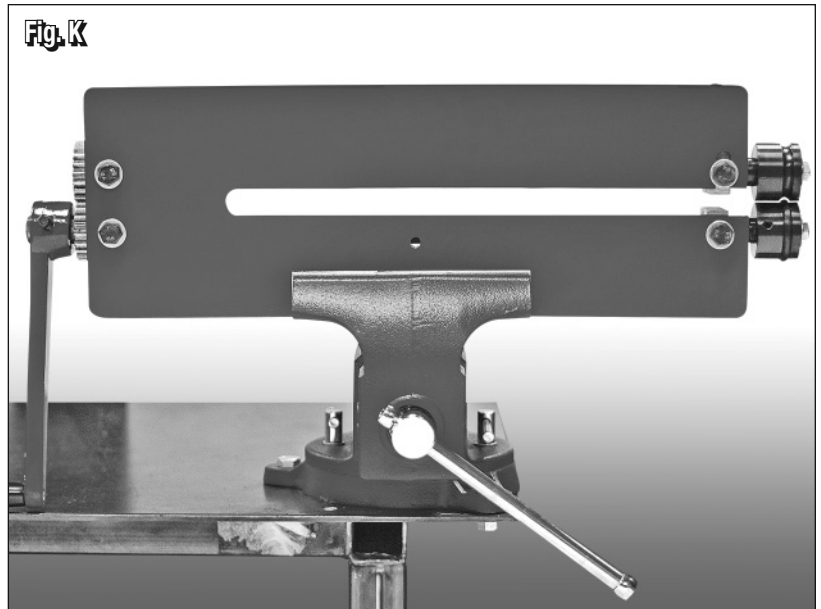

## STORAGE

- Remove Handle.
- Apply a thin film of light oil or rust-preventive to all bare steel areas.
- Store in a clean, dust-free, dry, dampness free area preferably covered with plastic sheeting.

## MAINTENANCE

**NOTE:** Maintenance should be performed before each use.

- Clean dirt and debris from Rollers Mandrel Dies.
- Check tightness of all hardware.
- Check operation for binding. Lubricate Bearing Blocks through the Zerk fittings periodically with medium bodied chassis grease.
- Add grease to the drive gears.

## OPTIONAL METALWORKING ITEMS

- #20552 Bead Roller Fence
- #51088 Shrinker/Stretcher Set
- #13475 Eastwood Electric Metal Shears
- #11797 Throatless Shear
- #14042 Versa Bend Sheet Metal Brake
- #20254 Eastwood 24" Slip Roll
- #20267 Eastwood Bead Roller Forming Dies
- #20268 Eastwood Polyurethane Lower Die



---

**If you have any questions about the use of this product, please contact**

The Eastwood Technical Assistance Service Department: 800.544.5118 >> email: [techelp@eastwood.com](mailto:techelp@eastwood.com)  
PDF version of this manual is available online >> [eastwood.com/28187manual](http://eastwood.com/28187manual)

The Eastwood Company 263 Shoemaker Road, Pottstown, PA 19464, USA  
US and Canada: 800.345.1178 Outside US: 610.718.8335  
Fax: 610.323.6268 [eastwood.com](http://eastwood.com)