

Eastwood[®]

DO THE JOB RIGHT.[®]

Part #31459

3/8" X 13" ARM
For Use with #31455 Belt Sander
INSTRUCTIONS



The optional **3/8" X 13" ARM FOR THE EASTWOOD #31455 MINI BELT SANDER** will enhance the versatility of the Mini Belt Sander by offering a smaller footprint alternative to the standard Arm. Shorter and narrower than the 1/2" x 18" Arm, it allows convenient reach into tighter areas.

CONTENTS

(1) 3/8" [9.6mm] x 13" [330mm] Arm

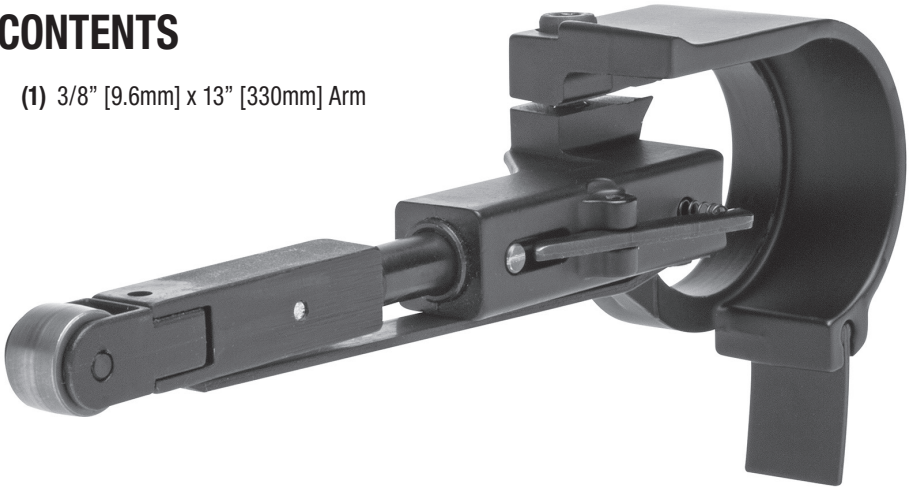

SPECIFICATIONS

RPM: 16,000 free speed

Replacement Belt Size: 3/8" x 13", minimum 16,000 RPM

SAFETY INFORMATION

The following explanations are displayed in this manual, on the labeling, and on all other information provided with this product:

⚠ DANGER

DANGER indicates a hazardous situation which, if not avoided, will result in death or serious injury.

⚠ WARNING

WARNING indicates a hazardous situation which, if not avoided, could result in death or serious injury.

⚠ CAUTION

CAUTION used with the safety alert symbol, indicates a hazardous situation which, if not avoided, could result in minor or moderate injury.

⚠ NOTICE

NOTICE is used to address practices not related to personal injury.

SAFETY INFORMATION



⚠ READ INSTRUCTIONS

- Thoroughly read and understand this manual before using.
- Save for future reference.



⚠ WARNING EXPLOSION HAZARD

- Do not exceed 90 psi (6.3 bar) of tool inlet pressure. Permanent tool damage and/or explosion could occur and cause personal injury.



⚠ WARNING HEALTH AND INJURY HAZARD

- Always wear ANSI approved eye and ear protection when operating this tool. Metal particles and dust can be ejected during the grinding/sanding process.
- Wear appropriate NIOSH approved respiratory protection. Hazardous dust is generated during the grinding/sanding process.
- This tool has high-speed, highly abrasive surfaces which can quickly cause severe injury. Keep fingers and hands away from moving parts when operating. Wear thick, well fitting work gloves and keep loose clothing, sleeves, cords, jewelry and hair away from moving parts.
- Do not force tool or exert side forces on belt drive while grinding or sanding as the tool body can suddenly kick back or twist causing severe hand or wrist injury. Belts can also be torn with excessive side force causing them to disintegrate and eject sharp pieces at high velocity.
- This tool will vibrate during use! Repeated exposure to vibration may cause physical injury.
- Always disconnect tool from air supply when changing abrasive belts to prevent accidental tool starting and potential injury.
- Always make sure the workpiece being sanded/ground is securely clamped or anchored to avoid sudden movements which could result in injury.
- Frequently inspect belt condition. If tears or holes develop, discontinue tool use immediately and replace damaged belt. ONLY USE replacement belts rated for 16,000 RPM or greater use otherwise serious injury or death can result in the event of belt failure.



ARM REMOVAL/INSTALLATION

⚠ WARNING INJURY HAZARD!

Disconnect air supply from the tool to prevent accidental starting and potential injury while removing or installing an Abrasive Belt.

1. Remove the Abrasive Belt as outlined in Eastwood #31455 Mini Belt Sander Instructions.
2. Using a 4mm Hex Key, (included with the Eastwood #31455 Mini Belt Sander) loosen the Angle Adjusting Screw located on the upper side of the Abrasive Arm Assembly (**FIG 1**) then remove the 1/2" x 18" Arm.
3. Slide the optional 3/8" x 13" Arm over the Tool Body, set at the desired angle then tighten the Angle Adjusting Screw with the 4mm Hex Key.
4. Install the 3/8" x 13" Abrasive Belt as outlined in Eastwood #31455 Mini Belt Sander Instructions.
5. Mini Belt Sander is once again ready for use.



AVAILABLE ITEMS

- #31460 5 Pack of 80 Grit, 3/8" x 13" Abrasive Belts.
- #31461 5 Pack of 120 Grit, 3/8" x 13" Abrasive Belts.

If you have any questions about the use of this product, please contact

The Eastwood Technical Assistance Service Department: 800.544.5118 >> email: techhelp@eastwood.com

PDF version of this manual is available online >> eastwood.com/31459manual

The Eastwood Company 263 Shoemaker Road, Pottstown, PA 19464, USA

US and Canada: 800.345.1178 Outside US: 610.718.8335

Fax: 610.323.6268 eastwood.com