

Eastwood[®]

DO THE JOB RIGHT.[®]

Item #31472

12PC BEARING SPLITTER/PULLER KIT

INSTRUCTIONS



The **EASTWOOD 12 PIECE BEARING SPLITTER/PULLER KIT** includes all the components required to pull and separate bearings and gears from transmission shafts, differential assemblies and other automotive components. This tool, constructed of robust, high-strength steel alloy forgings, will provide years of reliable service.

CONTENTS

- (1) 6" Yoke - A
- (1) 9/16" Pressure Screw - B
- (2) 2" Bearing Separator Jaws - C
- (2) 3" Bearing Separator Jaws - D
- (2) 4" Hex Posts, Male/Male - E
- (2) 5" Hex Posts, Male/Male - F
- (2) 4" Hex Post Extensions, Male/Female - G
- (2) 5" Hex Post Extensions, Male/Female - H
- (1) Heavy-Duty, Blow Molded Case

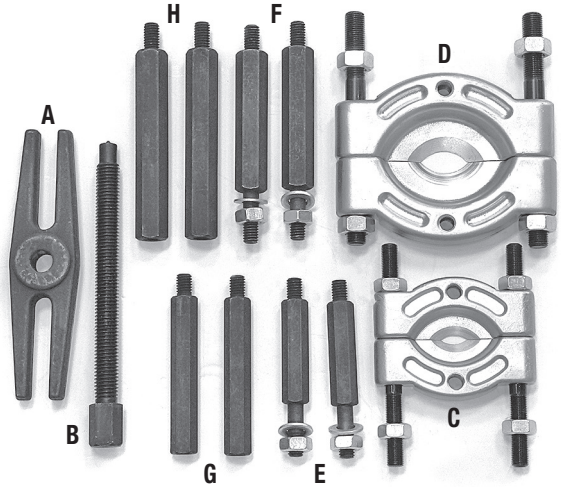

SAFETY INFORMATION

The following explanations are displayed in this manual, on the labeling, and on all other information provided with this product:

⚠ DANGER

DANGER indicates a hazardous situation which, if not avoided, will result in death or serious injury.

⚠ WARNING

WARNING indicates a hazardous situation which, if not avoided, could result in death or serious injury.

⚠ CAUTION

CAUTION used with the safety alert symbol, indicates a hazardous situation which, if not avoided, could result in minor or moderate injury.

⚠ NOTICE

NOTICE is used to address practices not related to personal injury.

SAFETY INFORMATION



⚠ READ INSTRUCTIONS

- Thoroughly read and understand these product instructions before using the Puller.
- Keep these product instructions for future reference.



⚠ WARNING IMPROPER MOTOR VEHICLE REPAIR WORK CAN RESULT IN INJURY OR DEATH!

- Performing automotive repair work can cause injury, death and vehicle accidents. DO NOT attempt to use this tool or begin work without proper training and a thorough understanding of motor vehicle mechanical systems.
- Always consult an authorized manufacturer's service manual or reference materials on the particular vehicle for the proper procedures before using this tool.



⚠ WARNING PINCH AND CRUSH HAZARD!

- This Puller consists of heavy metal components which can present a hand/finger pinch hazard and cause potentially serious injuries if dropped. Avoid pinching hands while handling. The use of safety shoes is strongly recommended. Keep fingers and hands away from moving parts when operating.



⚠ CAUTION FALL HAZARD!

- Parts may suddenly release while being pulled. Failure to ensure proper footing can quickly result in a fall which could inflict serious personal injury or property damage.



⚠ CAUTION EYE INJURY HAZARD!

- Impacting metal components of tool may release chips. Wear ANSI approved eye protection while using.

BEARING/GEAR PULLER ASSEMBLY

FOR BEARING/GEAR PULLING

- Select the Bearing Separator Jaw size **(C OR D)** as required.
- Measure the distance from the inner surface of the bearing or gear to be pulled and the end of the shaft it is mounted to.
- Select the set of Posts **(E OR F)** and Extensions **(G OR H)** to fit the Bearing Separator Jaws **(C OR D)** being used.
- The selected components must be assembled from the Jaws outward.
- Place the halves of the Jaws **(C OR D)** with the beveled edges around the back of the bearing or gear to be pulled.
- Draw the halves inward by tightening the nuts on the Jaw Stems.
- Determine whether Post Extensions **(G OR H)** are needed.
- Thread the ends of the selected Post Extensions **(G OR H)** (if needed) into the threaded holes of the Jaws.
- Thread the non-shouldered ends of the Posts **(E OR F)** into the Post Extensions **(G OR H)** or directly into the threaded holes of the Jaws **(C OR D)**.
- Center and place the open ends of the Yoke **(A)** (with the offset boss facing outward) over the shouldered ends of the Posts **(E OR F)**.
- Place a washer over the threaded Post ends and against the face of the Yoke **(A)**.
- Thread the Nuts over the exposed Post threads and tighten in place.
- Thread the Pressure Screw **(B)** into the Yoke **(A)** as far as necessary to contact the end of the shaft to be pulled against.
- Following the above procedure, the assembly should resemble that in Fig 1 **(FIG 1)**.

FIG. 1

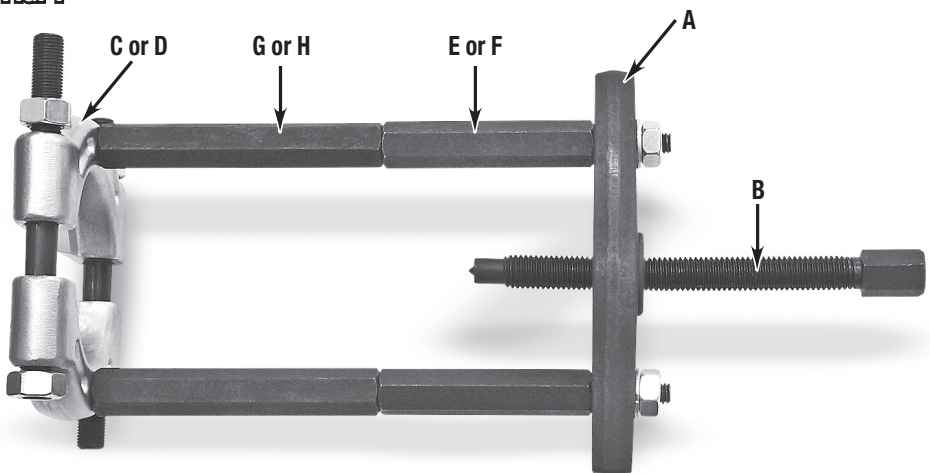

FOR BEARING/HOUSING SEPARATING

- Select the needed Bearing Separator Jaw size **(C OR D)** as required **(FIG 2)**.
- Place the halves of the Jaws **(C OR D)** with the beveled edges around the halves of the bearing and housing to be separated.
- Draw the halves inward by tightening the nuts on the Jaw Stems.

FIG. 2

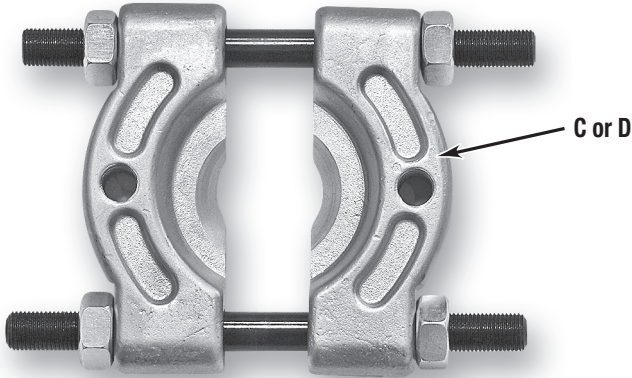

BEARING/GEAR PULLER OPERATION

FOR BEARING/GEAR PULLING

- Be sure the nuts keeping tension on the Jaw **(C OR D)** halves are kept tight and the two halves of the Jaw are drawn in evenly.
- Rotate the Hex on the end of the Pressure Screw **(B)** slowly and steadily exerting pressure until the bearing or gear is released from its shaft.

FOR BEARING SEPARATING

- Apply a small amount of a heavy-bodied lubricant on the beveled edges of the Jaws **(C OR D)**.
- Draw the Jaw halves inward by tightening the nuts on the Jaw Stems equally. It is best to alternate tightening each side with one turn each steadily exerting pressure until the bearing and housing separates.

ADDITIONAL ITEMS

- #31902 Eastwood 1/2" Drive 1000 Ft/Lb Composite Impact Air Wrench
- #13622 Eastwood 1/2" Drive Digital Electronic Torque-Angle Wrench
- #31338 1/2" Micrometer Torque Wrench, 30-250 ft/lbs.
- #14533 Eastwood 10 Piece Bearing and Seal Driver Set

If you have any questions about the use of this product, please contact

The Eastwood Technical Assistance Service Department: 800.343.9353 >> email: tech@eastwood.com

PDF version of this manual is available at eastwood.com

The Eastwood Company 263 Shoemaker Road, Pottstown, PA 19464, USA

800.343.9353 eastwood.com