



DO THE JOB RIGHT.®

Item #31638

SWING ARM TIRE CHANGER INSTRUCTIONS



The **EASTWOOD TIRE CHANGER** offers the ability to quickly and easily mount and dismount tires on most any steel or alloy wheels without damage. Constructed with the same pneumatic functions as other professional machines, this Tire Machine is ideal for the avid home hobbyist, race shop or small business.

CONTENTS

- (1) Main Tire Machine Base Unit - [A]
- (1) Vertical Tower - [B]
- (4) M12 Nuts - [C]
- (4) M12 Washers - [D]
- (1) Slide Shaft Spring - [E]
- (1) Plastic Cover - [F]
- (20) Mount/Dismount Shoe “Duckhead” Replaceable Plastic Glides – [G]
- (20) Mount/Dismount Shoe “Ducktail” Replaceable Plastic Glides – [H]
- (1) Coiled Air Hose - [J]
- (1) Gauge/Fill Gun - [K]
- (1) 1/4” MNPT, Male Coupler – [L]
- (1) Tire Iron – [M]
- (4) Rim Protectors – [N]

SPECIFICATIONS

Rim Diameter Range:

- External Clamping: 10” to 21”
- Internal Clamping: 12” to 24”

Maximum Tire Width: 14”

Maximum Tire Diameter: 39”

Turntable Rotation Speed: 6 RPM

Power Requirements: 120 VAC, 60hz

Air Supply Operational Range: 115 to 145 PSI [8 to 10 Bar]

TOOLS REQUIRED

- 17mm Wrench
- 16mm Wrench
- 8mm Hex Key
- 3mm Hex Key
- 2mm Hex Key

SAFETY INFORMATION

The following explanations are displayed in this manual, on the labeling, and on all other information provided with this product:

⚠ DANGER

DANGER indicates a hazardous situation which, if not avoided, will result in death or serious injury.

⚠ WARNING

WARNING indicates a hazardous situation which, if not avoided, could result in death or serious injury.

⚠ CAUTION

CAUTION used with the safety alert symbol, indicates a hazardous situation which, if not avoided, could result in minor or moderate injury.

⚠ NOTICE

NOTICE is used to address practices not related to personal injury.

GENERAL SAFETY RULES

⚠ WARNING

Read all instructions. Failure to follow all instructions listed below may result in electric shock, fire and/or serious injury. The term “electrical equipment ” in all of the warnings listed below refers to your mains-operated (corded) power tool or battery-operated (cordless) power tool.

SAVE THESE INSTRUCTIONS

1) WORK AREA SAFETY

- a) Keep work area clean and well lit. Cluttered or dark areas invite accidents.
- b) Do not operate electrical equipment in explosive atmospheres, such as in the presence of flammable liquids, gases or dust. Electrical equipment creates sparks which may ignite the dust or fumes.
- c) Keep children and bystanders away while operating electrical equipment. Distractions can cause you to lose control.

2) ELECTRICAL SAFETY

- a) Electrical equipment plugs must match the outlet. Never modify the plug in any way. Do not use any adapter plugs with earthed (grounded) electrical equipment. Unmodified plugs and matching outlets will reduce risk of electric shock.
- b) Avoid body contact with earthed or grounded surfaces such as pipes, radiators, ranges and refrigerators. There is an increased risk of electric shock if your body is earthed or grounded.
- c) Do not expose electrical equipment to rain or wet conditions. Water entering electrical equipment will increase the risk of electric shock.
- d) Do not abuse the cord. Never use the cord for carrying, pulling or unplugging the electrical equipment. Keep cord away from heat, oil, sharp edges or moving parts. Damaged or entangled cords increase the risk of electric shock.
- e) When operating electrical equipment outdoors, use an extension cord suitable for outdoor use. Use of a cord suitable for outdoor use reduces the risk of electric shock.

SAFETY INFORMATION

3) PERSONAL SAFETY

- a) Stay alert, watch what you are doing and use common sense when operating electrical equipment. Do not use electrical equipment while you are tired or under the influence of drugs, alcohol or medication. A moment of inattention while operating electrical equipment may result in serious personal injury.
- b) Use safety equipment. Always wear eye protection. Safety equipment such as dust mask, non-skid safety shoes, hard hat, or hearing protection used for appropriate conditions will reduce personal injuries.
- c) Avoid accidental starting. Ensure the switch is in the off-position before plugging in. Carrying electrical equipment with your finger on the switch or plugging in electrical equipment that have the switch on invites accidents.
- d) Remove any adjusting key or wrench before turning the electrical equipment on. A wrench or a key left attached to a rotating part of the electrical equipment may result in personal injury.
- e) Do not overreach. Keep proper footing and balance at all times. This enables better control of the electrical equipment in unexpected situations.
- f) Dress properly. Do not wear loose clothing or jewelry. Keep your hair, clothing and gloves away from moving parts. Loose clothes, jewelry or long hair can be caught in moving parts.
- g) If devices are provided for the connection of dust extraction and collection facilities, ensure these are connected and properly used. Use of these devices can reduce dust-related hazards.

4) POWER TOOL USE AND CARE

- a) Do not force the electrical equipment. Use the correct electrical equipment for your application. The correct electrical equipment will do the job better and safer at the rate for which it was designed.
- b) Do not use the electrical equipment if the switch does not turn it on and off. Any electrical equipment that cannot be controlled with the switch is dangerous and must be repaired.
- c) Disconnect the plug from the power source and/or the battery pack from the electrical equipment before making any adjustments, changing accessories, or storing electrical equipment. Such preventive safety measures reduce the risk of starting the electrical equipment accidentally.
- d) Store idle electrical equipment out of the reach of children and do not allow persons unfamiliar with the electrical equipment or these instructions to operate the electrical equipment. Electrical equipment is dangerous in the hands of untrained users.
- e) Maintain electrical equipment. Check for misalignment or binding of moving parts, breakage of parts and any other condition that may affect the electrical equipment operation. If damaged, have the electrical equipment repaired before use. Many accidents are caused by poorly maintained electrical equipment.
- f) Keep cutting tools sharp and clean. Properly maintained cutting tools with sharp cutting edges are less likely to bind and are easier to control.
- g) Use the electrical equipment, accessories and tool bits etc., in accordance with these instructions and in the manner intended for the particular type of electrical equipment, taking into account the working conditions and the work to be performed. Use of the electrical equipment for operations different from those intended could result in a hazardous situation.

5) SERVICE

- a) Have your electrical equipment serviced by a qualified repair person using only identical replacement parts. This will ensure that the safety of the electrical equipment is maintained.

SAFETY INFORMATION



⚠ WARNING PINCH AND CRUSH HAZARD!

- Keep fingers and hands away from moving parts when operating.



⚠ WARNING CUT HAZARD!

- Contacting metal edges on wheels can cause serious cuts. Wear thick, well-fitting work gloves to prevent cuts from handling wheels & tires.



⚠ WARNING INJURY HAZARD!

- This tool can quickly start up while connected to an electrical supply causing serious personal injury. Always disconnect the Tire Machine from the electrical supply before making adjustments or performing maintenance.
- The Tire Machine involves the mounting/dismounting of large, heavy wheel/tire combinations which can cause serious injuries if dropped. The use of safety shoes is strongly recommended.



⚠ WARNING EYE INJURY HAZARD!

- Moving/rubbing components under great pressures can suddenly eject particles at high velocity. Always wear ANSI approved eye protection when operating this equipment.



⚠ WARNING BURST HAZARD!

- Excessive air pressure can cause tool to explode resulting in tool damage and personal injury. Do not exceed 145 psi [10 bar] of tool inlet air pressure.



⚠ CAUTION INJURY HAZARD!

- The Tire Machine consists of large moving components which can present a hand/finger pinch hazard injuries if dropped. Avoid pinching hands while handling parts during assembly and/or operation.



⚠ CAUTION

- The Tire Machine was specifically designed to be operated by one person only. Never have one person operate the pedals while another handles the wheel mounting/dismounting or serious injury could occur.
- Inspect rim and tire before mounting or dismounting for damaged or bent conditions. Attempting to mount or dismount a damaged rim and/or tire can result in serious injury and severe Tire Mounting Machine damage.

⚠ NOTICE

- Wheels and tires **MUST** be clean and free of all mud, grit, rust or other debris as this can cause machine malfunction and failure of tires to seal.

TIRE MACHINE SAFETY FEATURE

⚠ NOTICE

Should a malfunction occur during the operation of the Tire Machine, releasing foot pressure from controls will stop motion immediately.

INSTALLATION LOCATION

- The Tire Machine **MUST** be installed on a solid and level concrete or similar surface for proper operation, accuracy and safety.
- There **MUST** be a minimum of 3 ft. of open space surrounding the Tire Machine.
- This Tire Machine **MUST** be firmly attached to the floor with suitable concrete anchors or similar hardware (not included).

TIRE MACHINE FEATURE DESCRIPTIONS

- "aa" Lock Lever
- "bb" Slide Shaft
- "cc" Spring Cap
- "dd" Mount/Dismount Shoe
- "ee" Air Regulator/Oiler
- "ff" Cushion Block
- "gg" Bead Breaker Blade
- "hh" Bead Breaker Pedal
- "jj" Turntable
- "kk" Rim Clamps
- "mm" Rim Clamp Pedal
- "nn" Wheel Diameter Adjustment Knob
- "pp" Turntable Pedal

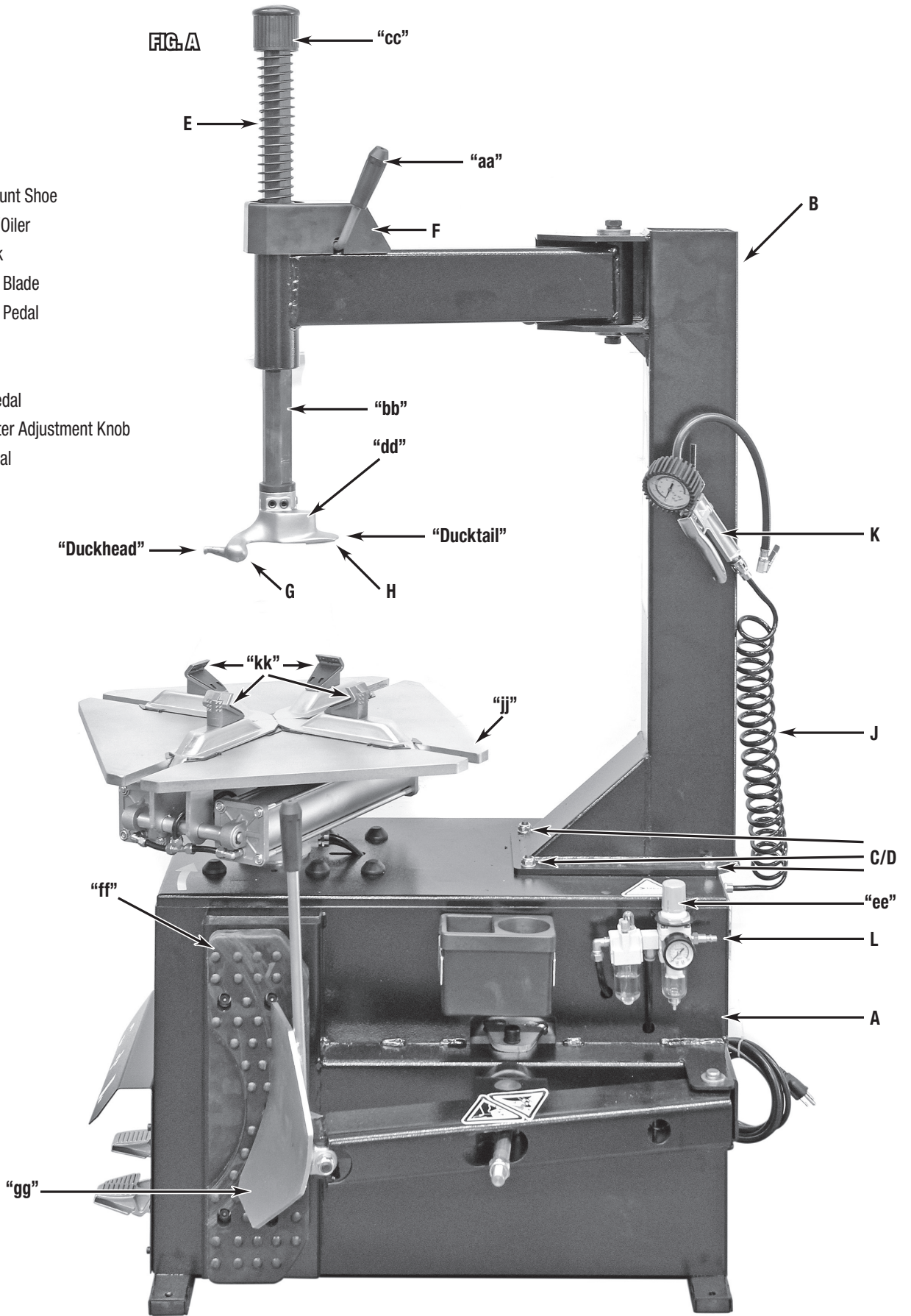
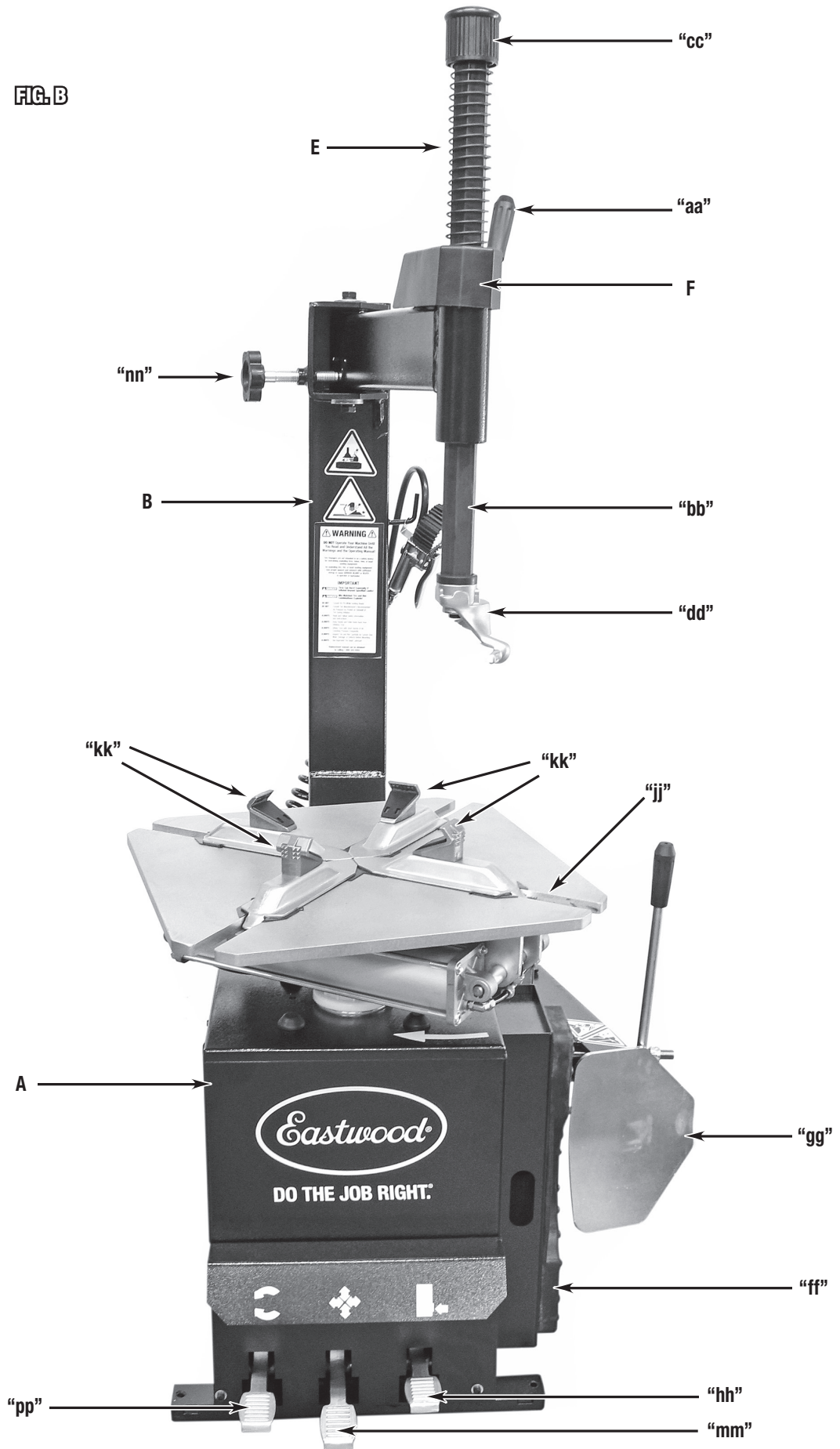

FIG. B



ASSEMBLY

⚠ WARNING PINCH AND CRUSH HAZARD!
Keep fingers and hands away from moving parts when operating.

⚠ CAUTION INJURY HAZARD!

- The Tire Machine consists of large moving components which can present hand/finger pinch hazard injuries if dropped.
- Avoid pinching hands while handling parts during assembly and/or operation.

VERTICAL TOWER [B] TO MAIN BASE UNIT [A] Reference FIGS A AND B

- Place the square flange of the Vertical Tower [B] onto the Main Base Unit [A] with the four corner holes aligned over the four M12 studs of the Main Base Unit. Note that the Pivoting Arm of the Vertical Tower must face the front end of the Main Base Unit.
- Use the four M12 Nuts [C] and Washers [D] and tighten securely with a 17mm wrench (not included).

SLIDE SHAFT SPRING [E] TO SLIDE SHAFT "BB" Reference FIGS A AND B

Remove the M10 Socket Head Cap Screw and protective metal shipping plate from the top of the Slide Shaft with an 8mm Hex Key (not included).

- Rotate the Lock Lever "aa" 90° from a vertical position down to horizontal to unlock the Slide Shaft "bb".
- Raise the Slide Shaft "bb" fully, rotate the Lock Lever "aa" up 90° to a vertical position to lock the Slide Shaft in place.
- Slip the Slide Shaft Spring [E] down over the Slide Shaft "bb".
- Install the Plastic Spring Retaining Cap "cc" over the end of the Slide Shaft and fasten with the M10 Socket Head Cap Screw.
NOTE: Some moderate pressure may be required to hold the Spring Cap "cc" in place while installing screw.
- Slip the Plastic Cover [F] down over the Slide Shaft and snap into place on the metal bracket of the Lock Lever assembly.

INSTALL MOUNT/DISMOUNT SHOE, HORIZONTAL [G] AND VERTICAL [H] PLASTIC GLIDES

- Snap the Mount/Dismount Shoe "dd", "Ducktail" Replaceable Plastic Glide [G] (*smaller* Glide) into the horizontal slot of the Mount/Dismount Shoe (FIG 1).
- Clip the Mount/Dismount Shoe "Duckhead" Replaceable Plastic Glide [H] (*larger* Glide) over the Roller of the Mount/Dismount Shoe (FIGS 2&3).

⚠ NOTICE

Operating the Tire Changing Machine without these Glides in place may result in severe damage to the wheel rim edge and face.

If you are unconcerned with wheel scratches and want to preserve the glides, you may remove one or both. Removing the Duckhead exposes the Roller which helps to smooth operation without the Duckhead.

FIG. 1

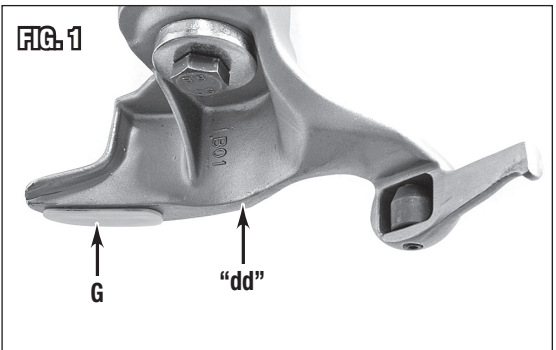

FIG. 2

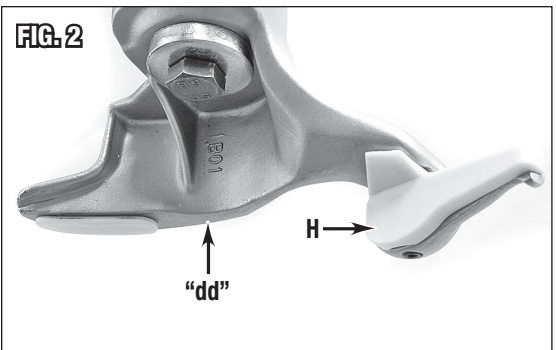
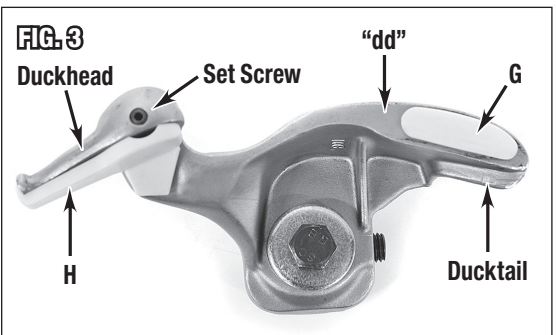
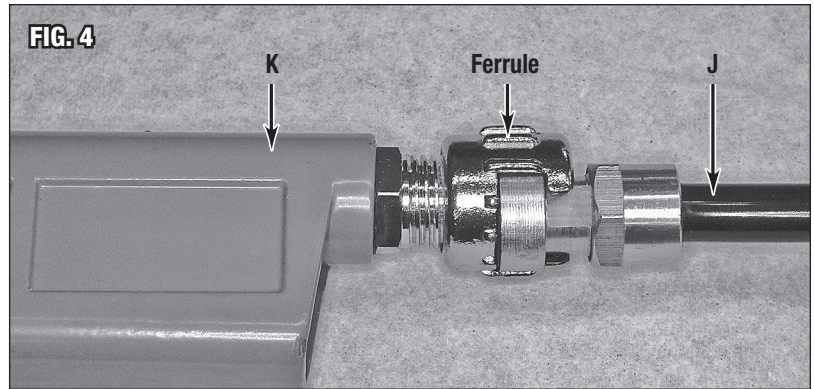

FIG. 3



⚠ WARNING BURST HAZARD!

Excessive air pressure can cause tool to explode resulting in tool damage and personal injury. Do not exceed 145 psi [10 bar] of tool inlet air pressure.



COILED AIR HOSE [J] AND GAUGE/FILL GUN [K]

- Rotate the Threaded, Slotted Ferrule located on the air inlet at the bottom of the Gauge/Fill Gun [K] in a “loosen” direction then slide the Flanged Brass Fitting on the end of the Coiled Air Hose [J] into the open slot then tighten the Ferrule to tightly retain the Flanged Brass Fitting (FIG 4).
- Rotate the Threaded, Slotted Ferrule located on the air outlet at the rear, lower right corner of the Mounting Machine in a “loosen” direction then slide the Flanged Brass Fitting on the end of the Coiled Air Hose [J] into the open slot, then tighten the Ferrule to tightly retain the Flanged Brass Fitting.

TIRE CHANGER OPERATION

Note that the Tire Changer has three main functions that are explained in the following three segments:

- “Breaking” the tire bead seal.
- Dismounting a tire from a wheel rim.
- Mounting a tire on a wheel rim.

Before beginning any work with the Tire Changer, the Air Regulator/Oiler “ee” should be set to a maximum of 145 PSI [10 Bar] Maximum of operating inlet air pressure by connecting to a clean and dry air supply then pushing down and turning the knob on the Air Regulator Clockwise or Counterclockwise as required.

⚠ WARNING PINCH AND CRUSH HAZARD!

Keep fingers and hands away from moving parts when operating.

⚠ WARNING CUT HAZARD!

Contacting metal edges on wheels can cause serious cuts. Wear thick, well-fitting work gloves to prevent cuts from handling wheels & tires.

⚠ WARNING INJURY HAZARD!

This tool can quickly start up while connected to an electrical supply causing serious personal injury. Always disconnect the Tire Machine from the electrical supply before making adjustments or performing maintenance.

⚠ WARNING EYE INJURY HAZARD!

Moving/rubbing components under great pressures can suddenly eject particles at high velocity. Always wear ANSI approved eye protection when operating this equipment.

⚠ WARNING BURST HAZARD!

Excessive air pressure can cause tool to explode resulting in tool damage and personal injury. Do not exceed 145 psi [10 bar] of tool inlet air pressure.

⚠ WARNING INJURY HAZARD!

The Tire Machine involves the mounting/dismounting of potentially large, heavy wheel/tire combinations which can present potentially serious injuries if dropped. The use of safety shoes is strongly recommended.

⚠ CAUTION INJURY HAZARD!

The Tire Machine consists of large moving components which can present a hand/finger pinch hazard injuries if dropped. Avoid pinching hands while handling parts during assembly and/or operation.

⚠ CAUTION

The Tire Machine was specifically designed to be operated by one person only. Never have one person operate the pedals while another handles the wheel mounting/dismounting or serious injury could occur.

⚠ CAUTION INJURY HAZARD!

Inspect rim and tire before mounting or dismounting for previous damage or bent conditions. Attempting to mount or dismount a damaged rim and/or tire can result in serious injury and severe Tire Mounting machine damage.

“BREAKING” THE TIRE BEAD SEAL

- Using a Valve Stem Core Removing Tool (not included) remove the valve stem core by unthreading and pulling it out to release all air from the tire.

⚠ CAUTION INJURY HAZARD!

To decrease the possibility of personal injury and damage to the tire and wheel, it is vitally important that all air first be released from the tire before beginning any work.

- Place the deflated tire and wheel rim vertically against the Rubber Cushion Block “ff” located on the lower, right side of the Tire Machine (FIG 5).
- Keeping hands free of the entire tire and wheel rim, use the Handle of the Bead Breaking Blade “gg” to pivot it to a position where the curved edge is in the same alignment as the curve of the wheel rim. At the same time, set the wheel and tire so that the edge of the rim is 1/4” to 3/8” from the edge of the Bead Breaking Blade (FIG 5).

⚠ NOTICE

DO NOT allow the edge of the Bead Breaking Blade “gg” to come in contact with the wheel rim or serious damage to the tire and rim as well as the Bead Breaking Blade will occur.

⚠ NOTICE

On vehicles equipped with remote tire pressure sensors, use extreme care not to press the Bead Breaking Blade “gg” in the vicinity of the valve stem and sensor or the sensor may be destroyed.



- Slowly and carefully depress the Bead Breaker Pedal “hh” located at the right of the 3 pedal cluster at the lower front of the Tire Machine (FIG 6).
- Pneumatic force will push the tire bead in and separate it from the wheel rim bead area (FIG 7). Release the Bead Breaker Pedal “hh” as soon as this occurs.

⚠ CAUTION

Failure to discontinue Bead Breaking Blade “gg” pressure on the tire can cause permanent damage to the tire sidewall and internal cord material.

- Release all Bead Breaking Blade pressure and contact, re-position the tire and wheel and repeat above process as needed to fully separate the tire bead from the rim. Reversing the tire and rim may be required to unseat the bead from the back side of the wheel rim.

⚠ NOTICE

On vehicles equipped with remote tire pressure sensors, use extreme care not to press the Bead Breaking Blade “gg” in the vicinity of the valve stem and sensor or the sensor may be destroyed.

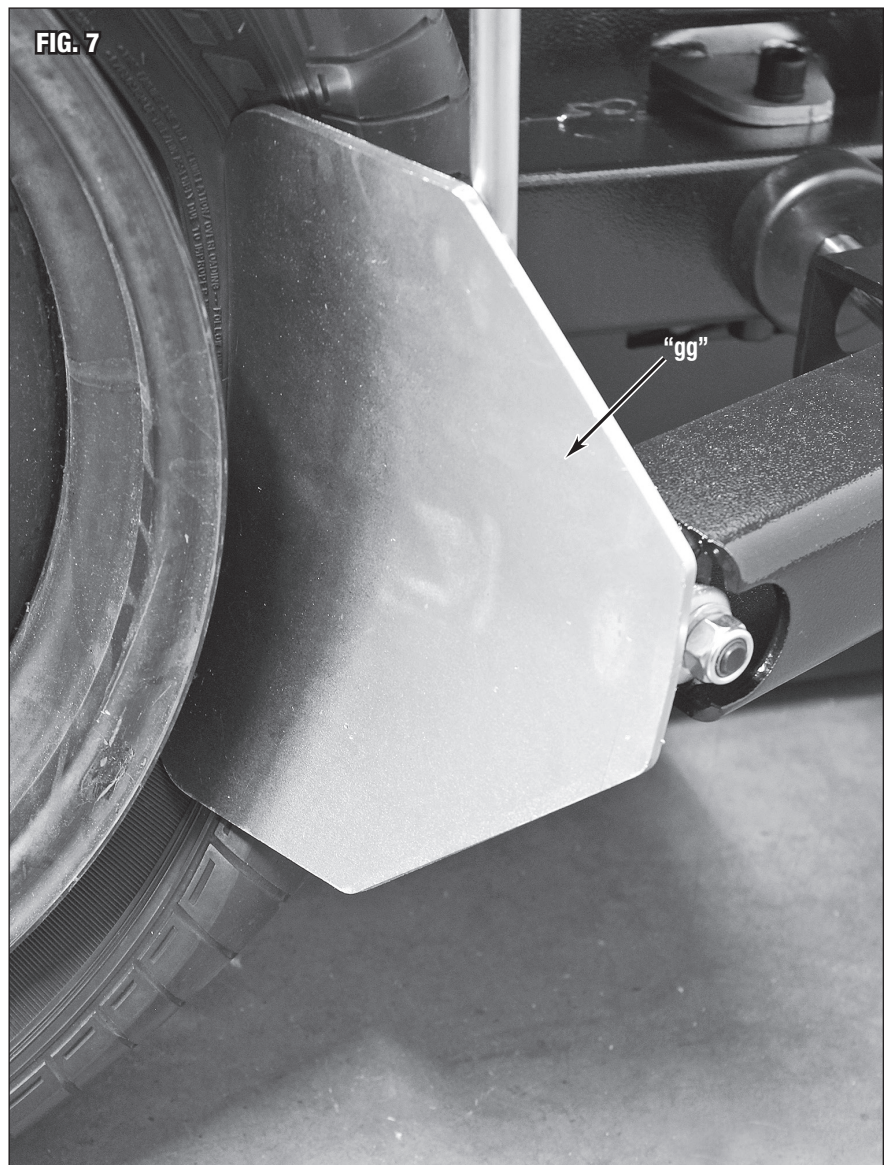
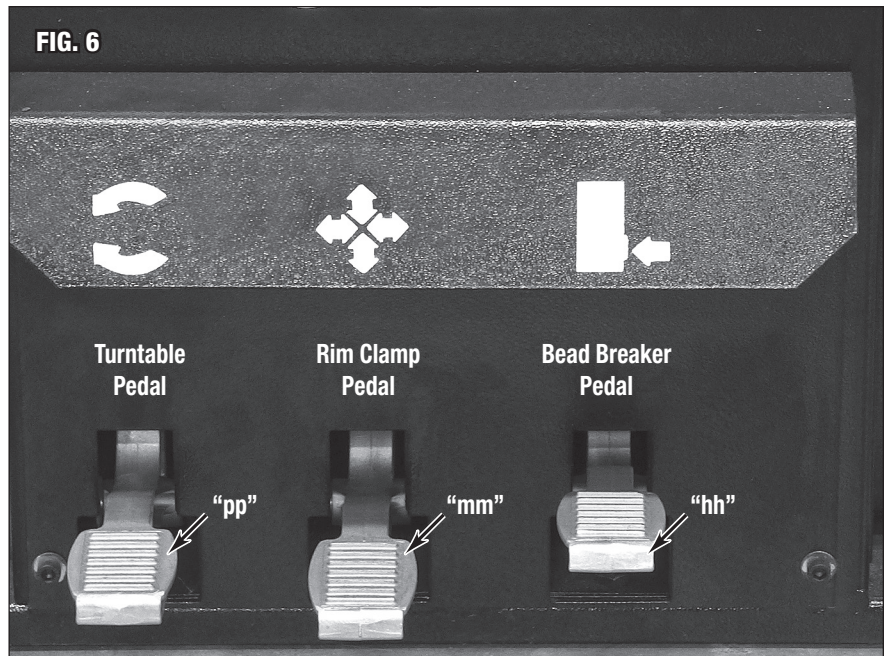

DISMOUNT TIRE FROM THE WHEEL RIM

- First, remove all clip-on balance weights from the wheel rim with a suitable wheel weight removal tool (not included).

⚠ NOTICE

Plastic Rim Protectors [N] (Fig 8) are shown in place over the Rim Clamps "kk" to protect wheel rims from being damaged.

- Place the wheel and tire face-up on the Turntable "jj".
- Using a suitable applicator (not included) apply tire bead lubricant or soap solution to the tire bead.

⚠ NOTICE

Failure to apply a lubricant can cause tire bead damage and add unnecessary strain to the Tire Machine components.

- Operate the four Rim Clamps "kk" of the Turntable "jj" (FIG 8) by depressing the Rim Clamp Pedal "mm" located in the center of the 3 pedal cluster (FIG 6).

⚠ NOTICE

It is important to recall that the Rim Clamps are operated by depressing the Rim Clamp Pedal once to move them outward on the Turntable while depressing the pedal a second time reverses the clamp travel inward toward the center of the Turntable.

- Depressing the Rim Clamp Pedal "mm" will move them outward and engage the teeth of the Rim Clamps "kk" with the inner surface of the wheel rim.
- Release the Lock Lever "aa" by rotating it 90° from a vertical position down to horizontal to unlock the Slide Shaft "bb".
- Allow the Mount/Dismount Shoe "Ducktail" Plastic Glide [H] to stop just above the face of the rim then lock the Slide Shaft.
- Rotate the Wheel Diameter Adjustment Knob "nn" (FIG 9) inward or outward to determine the distance of the "Duckhead" Plastic Glide [G] of the Mount/Dismount Shoe in relation to the edge of the wheel rim bead area (FIG 10).
- With the position of the Mount/Dismount Shoe properly set, the "Ducktail" Plastic Glide [H] surface will be from 1/16" to 1/8" away from the front face of the wheel rim and the "Duckhead" Plastic Glide [G] surface will be from 1/16" to 1/8" away from the outer diameter edge of the wheel rim bead (FIG 10).

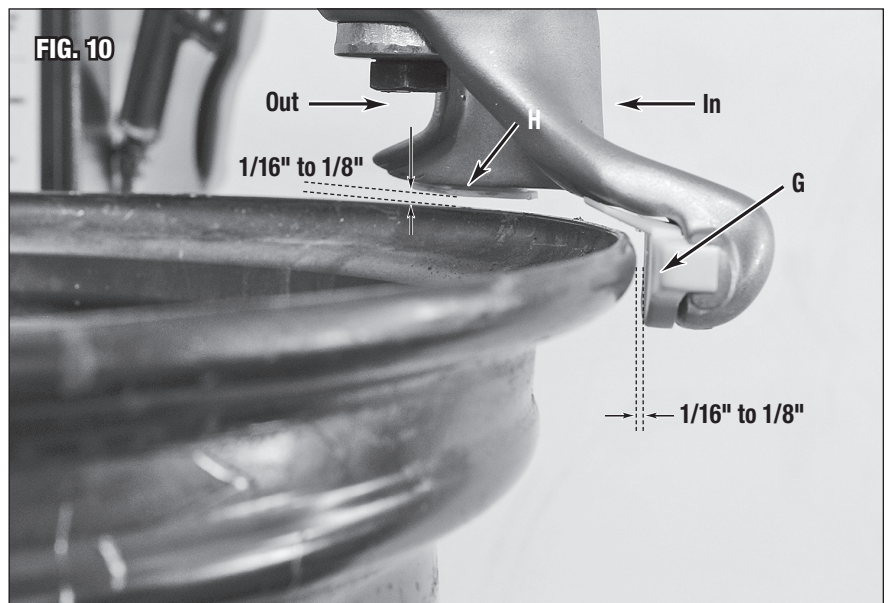
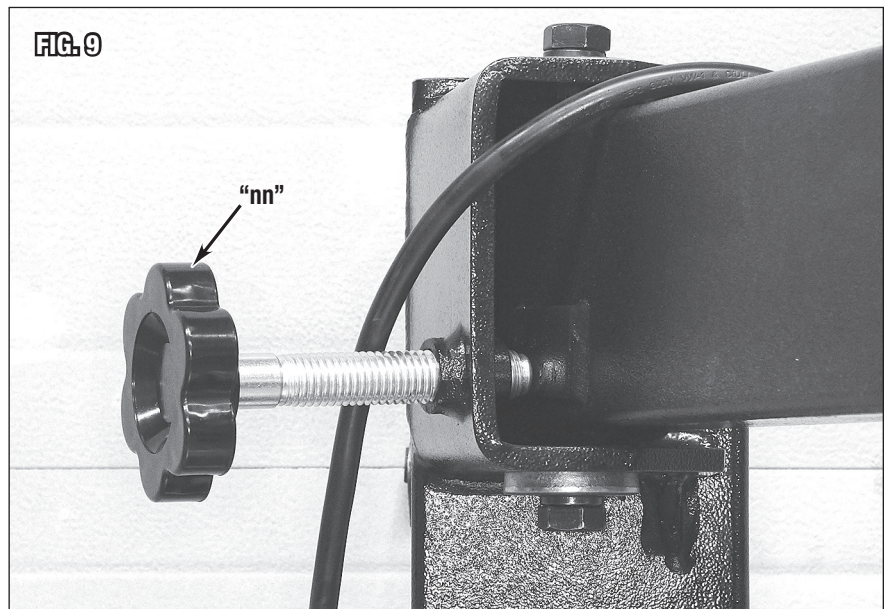
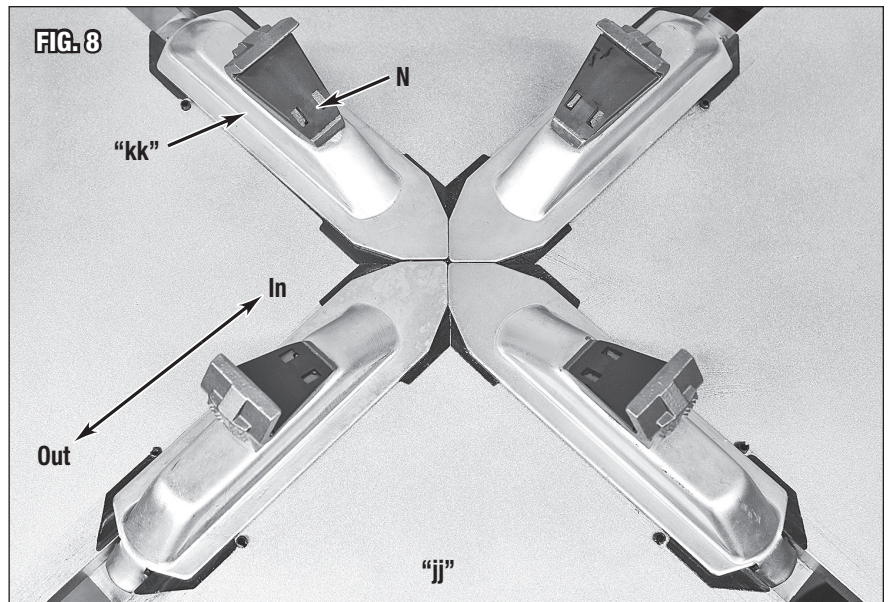

- Place the Tire Iron [M], under the tire bead and over the rounded beak of the “Duckhead” portion of the Mount/Dismount Shoe “dd” and use it to pull the tire bead up and over the entire Mount/Dismount Shoe (FIG 11).
- At this point, hold the Tire Iron [M] in place and depress the Turntable Pedal “pp” located at the left of the 3 pedal cluster. This will cause the Turntable to rotate in a Clockwise direction and the Mount/Dismount Shoe will pull the tire bead off the wheel rim (FIG 12).

▲ NOTICE

Lifting the Turntable Pedal with the toe of your shoe will rotate the Turntable in the opposite Counter-Clockwise direction.

- Pull the tire up so the inner tire bead is now under the outer bead section of the wheel rim (FIG 13).
- Repeat the above several steps once again using the Mount/Dismount Shoe and Tire Iron to pull the inner tire bead off the rim (FIG 13).
- Unlock the Slide Shaft, raise it and remove tire.



MOUNTING TIRE ON THE WHEEL RIM

- Be sure the bead area of the rim is clean and free of rust, corrosion, old tire remnants or other debris as failure to do so will prevent a good bead seal.
- Place the wheel face-up on the Turntable “jj”.

⚠ NOTICE

Plastic Rim Protectors (N) are in place over the Rim Clamps “kk” to protect wheel rims from being damaged.

- Operate the four Rim Clamps “kk” of the Turntable “jj” by depressing the Rim Clamp Pedal “mm” located in the center of the 3 pedal cluster (FIG 6).

⚠ NOTICE

It is important to recall that the Rim Clamps are operated by depressing the Rim Clamp Pedal once to move them outward on the Turntable while depressing the pedal a second time reverses the clamp travel inward toward the center of the Turntable.

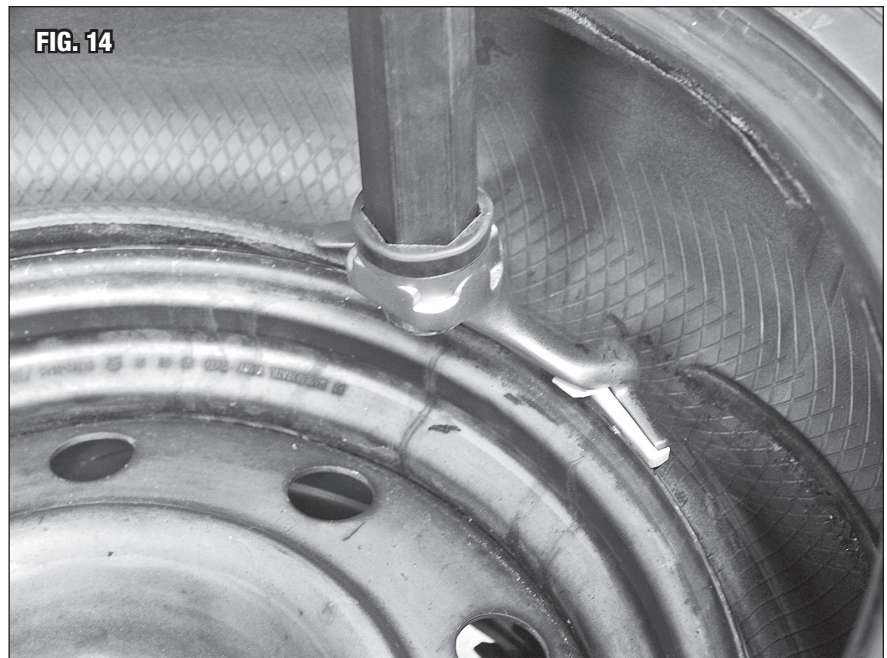

- Depressing the Rim Clamp Pedal “mm” will move them outward and engage the teeth of the Rim Clamps “kk” with the inner surface of the wheel rim.
- Release the Lock Lever by rotating it 90° from a vertical position down to horizontal to unlock the Slide Shaft.
- Allow the Mount/Dismount Shoe, “Ducktail” Plastic Glide [H] to stop just above the face of the rim then lock the Slide Shaft.
- Rotate the Wheel Diameter Adjustment Knob “nn” inward or outward to determine the distance of the “Duckhead” Plastic Glide [G] of the Mount/Dismount Shoe in relation to the edge of the wheel rim bead area (FIGS 9 & 10).
- If desired, install a new Valve Stem (not included) into the Wheel Rim.
- Using a suitable applicator (not included) apply tire bead lubricant or soap solution liberally to the tire bead.

⚠ NOTICE

Failure to apply a lubricant can cause tire bead damage and add unnecessary strain to the Tire Machine components.

- Place the inner side of the tire over the outer face of the wheel rim with the bead slipped over the side and under the Mount/Dismount Shoe.
- At this point, depress the Turntable Pedal “pp” located at the left of the 3 pedal cluster. This will cause the Turntable to rotate in a Clockwise direction and the tail of the Mount/Dismount Shoe will push the tire bead onto the wheel rim. Grasping the tire by the tread area and lifting/pulling may help the process (FIG 14).

⚠ NOTICE

Lifting the Turntable Pedal with the toe of your shoe will rotate the Turntable in the opposite Counter-Clockwise direction if needed.

- Repeat the 2 preceding steps with the outer bead of the tire to complete the mounting process.

MAINTENANCE

⚠ WARNING PINCH AND CRUSH HAZARD!
Keep fingers and hands away from moving parts when operating.

⚠ WARNING INJURY HAZARD!
This tool can quickly start up while connected to an electrical supply causing serious personal injury. Always disconnect the Tire Machine from the electrical supply before making adjustments or performing maintenance.

⚠ WARNING EYE INJURY HAZARD!
Moving/rubbing components under great pressures can suddenly eject particles at high velocity. Always wear ANSI approved eye protection when operating this equipment.

⚠ WARNING BURST HAZARD!
Excessive air pressure can cause tool to explode resulting in tool damage and personal injury. Do not exceed 145 psi [10 bar] of tool inlet air pressure.

⚠ CAUTION BURST HAZARD!
Disconnect compressed air source and electrical supply before servicing Tire Machine.

ADJUSTMENTS

The Mount/Dismount Shoe positioning was adjusted at the factory so that the inner curve will be concentric to the outer edge of wheel rims with the “Duckhead” and “Ducktail” sections at equal distance from any size wheel rim diameter. With use, this may require periodic checking and adjustment. To do so:

- Place a wheel face-up on the Turntable “jj”.
- Depress the Rim Clamp Pedal “mm” to clamp it in place (FIG 6).
- Release the Lock Lever to unlock the Slide Shaft “bb”.
- Allow the Mount/Dismount Shoe “Ducktail” Plastic Glide [G] to stop just above the face of the rim then lock the Slide Shaft.
- Rotate the Wheel Diameter Adjustment Knob “nn” inward or outward to determine the distance of the “Duckhead” Replaceable Plastic Glide [H] of the Mount/Dismount Shoe in relation to the edge of the wheel rim bead area (FIGS 9 & 10).
- Check for any variation in distance from the “Duckhead” and the “Ducktail” ends of the Mount/Dismount Shoe and the outer edge of the wheel rim.
- If the distances are unequal, adjustment is required.

To adjust:

- Loosen the large bolt at the underside of the Mount/Dismount Shoe with a 16mm wrench (not included) (FIG 15).
- Loosen the set-screw on the “Duckhead” side with a 6mm hex key (not included) (FIG 16).
- Using the same 6mm hex key, turn the 2 adjusting screws on the inner side in or out to rotate the Mount/Dismount Shoe as required to bring it into alignment (FIG 16).
- Re-tighten the set-screw and the large bolt to lock in the adjustment and check once again.

FIG. 15

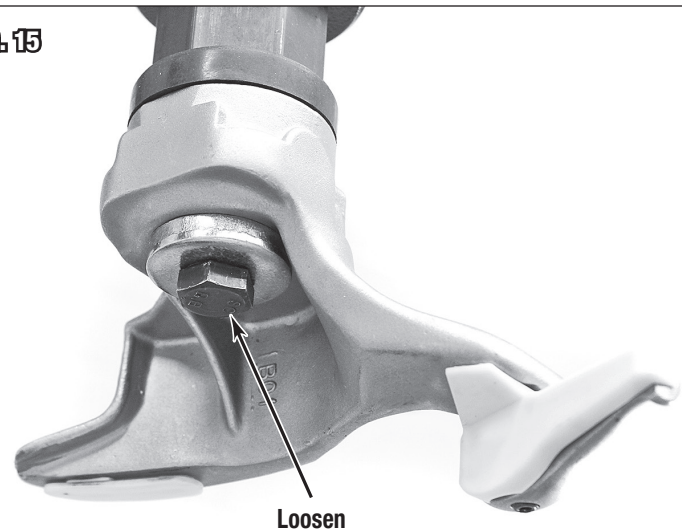
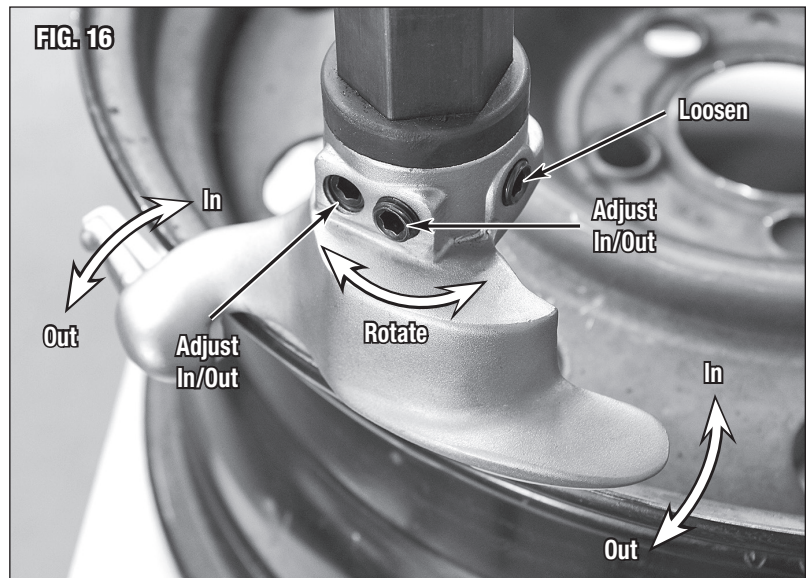
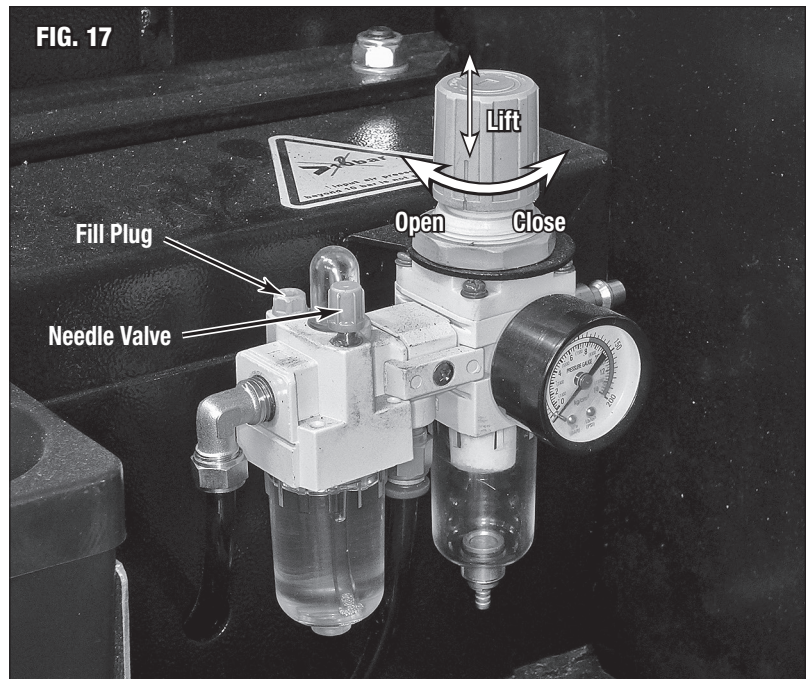

FIG. 16



LUBRICATION

- The Automatic Oiler attached to the Air Regulator/Oiler “ee” must be kept full of a good quality air tool oil by removing the fill plug (**FIG 17**) with a 3mm hex key (not included), adding oil and replacing the plug. This is critical to keep the various pneumatic actuating cylinders and valves in the assembly properly lubricated. Note that the Needle Valve (**FIG 17**) is used to control the amount of oil dispensed into the system.
- The slots in the Turntable in which the four sliding Rim Clamps ride in **MUST** be cleaned of dirt and grit accumulation and kept well lubricated by adding a good quality automotive chassis grease after every 2 hours of operation time.
- The hexagonal shaft of the Slide Shaft **MUST** be cleaned of dirt and grit accumulation and kept well lubricated by adding a good quality automotive chassis grease after every 4 hours of operation time.
- The pivoting arm joint of the Vertical Tower must be lubricated with several drops of a good quality motor oil after every week of operating time.
- The pivoting arm joint of the Bead Breaker must be lubricated with several drops of a good quality motor oil after every week of operating time.
- The pivoting joint Bead Breaker Blade must be lubricated with several drops of a good quality motor oil after every week of operating time.



GENERAL MAINTENANCE

- Disconnect air supply from inlet to release all residual air pressure in Machine.
- After each use, drain water from the moisture trap on the Regulator Unit by gripping the brass nipple on the underside clear vessel of the Regulator and pulling it down.
- After each use, inspect the machine for any damaged components or loose fasteners and tighten or make repairs as necessary.
- Keep machine out of damp environments, extreme temperatures and keep covered when not in use.
- Always keep air and electrical power supply disconnected when not in use.

TROUBLESHOOTING

⚠ WARNING PINCH AND CRUSH HAZARD!
Keep fingers and hands away from moving parts when operating.

⚠ WARNING CUT HAZARD!
Contacting metal edges on wheels can cause serious cuts. Wear thick, well-fitting work gloves to prevent cuts from handling wheels & tires.

⚠ WARNING INJURY HAZARD!
This tool can quickly start up while connected to an electrical supply causing serious personal injury. Always disconnect the Tire Machine from the electrical supply before making adjustments or performing maintenance.

⚠ WARNING EYE INJURY HAZARD!
Moving/rubbing components under great pressures can suddenly eject particles at high velocity. Always wear ANSI approved eye protection when operating this equipment.

⚠ WARNING BURST HAZARD!
Excessive air pressure can cause tool to explode resulting in tool damage and personal injury. Do not exceed 145 psi [10 bar] of tool inlet air pressure.

⚠ WARNING INJURY HAZARD!
The Tire Machine involves the mounting/dismounting of potentially large, heavy wheel/tire combinations which can present potentially serious injuries if dropped. The use of safety shoes is strongly recommended.

⚠ CAUTION INJURY HAZARD!
The Tire Machine consists of large moving components which can present a hand/finger pinch hazard injuries if dropped. Avoid pinching hands while handling parts during assembly and/or operation.

⚠ CAUTION
The Tire Machine was specifically designed to be operated by one person only. Never have one person operate the pedals while another handles the wheel mounting/dismounting or serious injury could occur.

⚠ CAUTION INJURY HAZARD!
Inspect rim and tire before mounting or dismounting for previous damage or bent conditions. Attempting to mount or dismount a damaged rim and or tire can result in serious injury and severe Tire Mounting machine damage.

⚠ CAUTION BURST HAZARD!
Disconnect compressed air source and electrical supply before servicing Tire Machine.

⚠ NOTICE
Wheels and tires **MUST** be clean and free of all mud, grit, rust, or other debris as this can cause machine malfunction and failure of tires to seal.

TROUBLESHOOTING

PROBLEM	CAUSE	CORRECTION
Poor/Sluggish Mounting Machine Performance	Dirt accumulation on moving parts of machine	Clean and lubricate all sliding/pivoting parts.
	Inadequate air supply	Make sure that a constant 115 to 145 PSI [8 to 10 Bar] air supply is available to power machine.
	Wheel not properly mounted	Remove wheel from Clamping Jaws and remount making sure that all Jaws are clamping evenly and the Wheel is level on the Turntable.
	Tire bead not lubricated	Add liberal amount of soapy solution or tire bead lubricant to tire bead.
	Damages wheel or tire	Inspect Wheel and/or Tire for bent or otherwise damaged condition and reject if found.
Excessive or Unusual Noise or Vibration	Wheel not properly mounted	Remove wheel from Clamping Jaws and remount making sure that all Jaws are clamping evenly and the Wheel is level on the Turntable.
	Tire bead not lubricated	Add liberal amount of soapy solution or tire bead lubricant to tire bead.
	Damaged wheel or tire	Inspect Wheel and/or Tire for bent or otherwise damaged condition and reject if found.
	Machine not securely fastened to floor	Securely fasten Machine to floor.
Bead Area of Tire is Torn by Machine on Mount or Dismount	Wheel not properly mounted	Remove wheel from Clamping Jaws and remount making sure that all Jaws are clamping evenly and the Wheel is level on the Turntable.
	Tire bead not lubricated	Add liberal amount of soapy solution or tire bead lubricant to tire bead.
	Damaged or missing Plastic Glides	Inspect and replace Plastic Guides.
	Damaged wheel or tire	Inspect Wheel and/or Tire for bent or otherwise damaged condition and reject if found.
Bead Area of Wheel Rim Scraped or Scratched by Machine on Mount or Dismount	Wheel not properly mounted	Remove wheel from Clamping Jaws and remount making sure that all Jaws are clamping evenly and the Wheel is level on the Turntable.
	Damaged or missing Plastic Glides	Inspect and replace Plastic Guides.
	Damaged wheel or tire	Inspect Wheel and/or Tire for bent or otherwise damaged condition and reject if found.
Plastic Guides are Wearing Rapidly Requiring Frequent Replacement	Mount/Dismount Shoe not adjusted properly	Follow Mount/Dismount adjustment procedure starting on page 15.

If you have any questions about the use of this product, please contact

The Eastwood Technical Assistance Service Department: 800.343.9353 >> email: tech@eastwood.com

PDF version of this manual is available at eastwood.com

The Eastwood Company 263 Shoemaker Road, Pottstown, PA 19464, USA 800.343.9353 eastwood.com

© Copyright 2023 Eastwood Automotive Group LLC 6/23 Instruction item #31638Q Rev 3