

2" RIGHT ANGLE ORBITAL SANDER INSTRUCTIONS



Your **ROCKWOOD 2" RIGHT ANGLE ORBITAL SANDER** is a heavy-duty professional quality tool ruggedly designed for many years of reliable service. It features an efficient orbital motion arbor to multiply sanding action. A high-torque, 4-vane, ball bearing air motor provides smooth operation and long life. Speed is easily controlled with an infinitely progressive trigger control.

CONTENTS

- (1) Right Angle Orbital Sander
- (1) 2", Hook and Loop Backing Pad
- (1) Arbor Key
- (1) 1/4" MNPT, Male quick disconnect inlet fitting

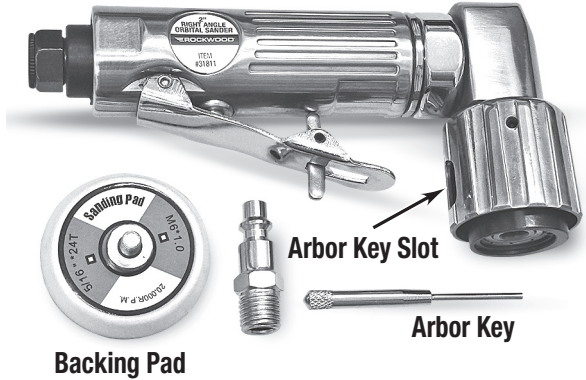

SPECIFICATIONS

- RPM:** 15,000 free speed
- Variable speed, 4 vane, ball bearing air motor**
- Air Consumption:** 7 CFM [198 L/min]
- Inlet thread size:** 1/4" FNPT
- Required Sanding Disc:** 2" Hook and Loop, minimum 15,000 RPM
- 5/16"-24 /M6 x 1.0 Arbor Thread**

SAFETY INFORMATION

The following explanations are displayed in this manual, on the labeling, and on all other information provided with this product:

⚠ DANGER

DANGER indicates a hazardous situation which, if not avoided, will result in death or serious injury.

⚠ WARNING

WARNING indicates a hazardous situation which, if not avoided, could result in death or serious injury.

⚠ CAUTION

CAUTION used with the safety alert symbol, indicates a hazardous situation which, if not avoided, could result in minor or moderate injury.

⚠ NOTICE

NOTICE is used to address practices not related to personal injury.



⚠ READ INSTRUCTIONS

- Thoroughly read and understand these product instructions before using this tool. Failure to follow all warnings can result in tool damage or serious physical injury.
- Keep these product instructions for future reference.



⚠ WARNING RESPIRATORY HAZARD!

- Dust and fine particulate matter is generated during the sanding process which can contain toxic substances such as lead, silica, solvents and others. Breathing this dust and fine particulate matter can cause many serious respiratory health conditions. Always use NIOSH approved respiratory protection while using this Sander.



⚠ WARNING EYE INJURY HAZARD!

- Rapidly rotating surfaces can eject metal particles, dirt and debris at high velocity. Always wear ANSI approved eye protection when operating this tool.



⚠ WARNING HEARING DAMAGE HAZARD!

- This Rockwood Pneumatic Tool emits high sound levels while operating. Use ANSI approved ear protection when operating.



⚠ CAUTION BURSTING HAZARD!

- Do not exceed 90 psi (6.3 bar) of tool inlet pressure. Permanent tool damage and/or explosion could occur and cause personal injury.



⚠ CAUTION INJURY HAZARD!

- This tool has high-speed, abrasive surfaces which can quickly cause injury. Keep fingers and hands away from moving parts when operating. Wear thick, well-fitting work gloves and keep loose clothing, sleeves, cords, jewelry and hair away from moving parts.
- This tool will eject sparks which can ignite flammable materials. Do not operate near flammable materials and keep all persons and pets away from the work area.
- Always make sure the workpiece is securely clamped or anchored to avoid sudden movements which could result in injury.
- Always disconnect tool from air supply when changing Backing Pad or Sanding Disc to prevent accidental tool starting and potential severe injury.
- Frequently inspect Backing Pad and tool condition. If cracks develop, discontinue tool use immediately and replace damaged pad. **ONLY USE** replacement Backing Pads rated for 15,000 RPM or greater use, otherwise severe injury or death can result in the event of Pad failure.

⚠ CAUTION VIBRATION INJURY HAZARD!

- This tool will vibrate during use! Repeated exposure to vibration may cause physical injury.

SET-UP

- Rotate the Eccentric Drum and Arbor so that the 1/8" [3mm] hole in the upper side aligns with the slotted opening in the Arbor Guard.
- Place the smaller end of the cylindrical Arbor Key through the slotted opening in the Arbor Guard and into the 1/8" [3mm] hole of the Eccentric Drum.
- Thread the shank of the Backing Pad into the Arbor.
- Using a good quality Teflon sealing tape (Not Included), thread the 1/4" MNPT, Male quick disconnect inlet fitting into the air inlet.

CONNECTION

- Be sure that the air supply to the tool is clean and dry. Moisture in the supply line will quickly damage the motor and valves.
- A minimum 3/8" I.D. air line should be used for optimal performance.

OPERATION

- Place a Hook and Loop Sanding Disc onto the face of the Backing Pad.
- Connect air supply, move throttle safety lever forward and depress trigger to begin rotating action. Speed is regulated by pressure applied to the trigger.

MAINTENANCE

- Add several drops of air tool oil before each use by dropping directly into the air inlet.
- If tool is to be unused for an extended period, add 10 drops of air tool oil directly to the air inlet, then store the tool, handle up.

TROUBLESHOOTING

Tool Doesn't Respond to Trigger Depression	Insufficient volume of air (CFM) to operate tool	Verify sufficient air supply to tool. (7 CFM @ 90 PSI minimum requirement).
	Moisture or other contamination in air supply	Check for moisture in air line and tool air inlet.
Tool Performance is Slow or Sluggish	Insufficient volume of air (CFM) to operate tool	Verify sufficient air supply to tool. (7 CFM @ 90 PSI minimum requirement).
	Moisture or other contamination in air supply	Check for moisture in air line and tool air inlet.
	Air Motor is lacking lubrication	Stop use immediately and add air tool oil directly to air inlet.
Tool is Excessively Noisy/ Emits High Pitched Sound	Air Motor is lacking lubrication	Stop use immediately and add air tool oil directly to air inlet.
Tool Vibrates Excessively During Use	Out of balance condition from damaged Backing Pad or Sanding Discs	Stop use immediately, check for and replace damaged Backing Pad or Sanding Discs.
	Loose Backing Pad	Tighten loose Backing Pad.

ADDITIONAL ITEMS

- #31812 Rockwood Replacement 2" Hook & Loop Pad
- #31644 Hook & Loop Sanding Disc 2 Inch 120 Grit 25 Pieces
- #31645 Hook & Loop Sanding Disc 2 Inch 180 Grit 25 Pieces
- #31646 Hook & Loop Sanding Disc 2 Inch 320 Grit 25 Pieces
- #31647 Hook & Loop Sanding Disc 2 Inch 400 Grit 25 Pieces
- #31648 Hook & Loop Sanding Disc 2 Inch 600 Grit 25 Pieces

If you have any questions about the use of this product, please contact

The Eastwood Technical Assistance Service Department: 800.343.9353 >> email: techelp@eastwood.com

PDF version of this manual is available online >> eastwood.com/31811manual

The Eastwood Company 263 Shoemaker Road, Pottstown, PA 19464, USA

US and Canada: 800.343.9353 Outside US: 610.718.8335

Fax: 610.323.6268 eastwood.com