

AIR DIE GRINDER

INSTRUCTIONS



The **ROCKWOOD AIR DIE GRINDER** is a heavy-duty professional quality tool ruggedly designed for many years of reliable service. It features positive 1/8" & 1/4", non-slip collets for quick, convenient and secure accessory changes. A high-torque, 4 vane, ball bearing motor provides smooth operation and long life. Speed is easily controlled with an infinitely progressive trigger control.

CONTENTS

- (1) Inline Die Grinder
- (1) 1/8" Collet
- (1) 1/4" Collet (installed)
- (2) 14mm/19mm
Combination Collet Wrenches
- (1) 1/4" MNPT, Male Quick
Disconnect Inlet Fitting

1/4" Collet (installed)

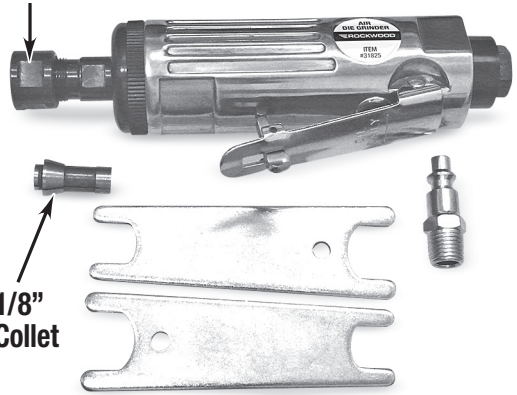

SPECIFICATIONS

- Collet Sizes:** 1/8" & 1/4" [3mm & 6mm]
RPM: 22,000 free speed
Air Consumption: 4 cfm [114 L/m] @ 90 PSI
Inlet thread size: 1/4" FNPT
Variable speed, 4 vane, ball bearing air motor

SAFETY INFORMATION

The following explanations are displayed in this manual, on the labeling, and on all other information provided with this product:

⚠ DANGER

DANGER indicates a hazardous situation which, if not avoided, will result in death or serious injury.

⚠ WARNING

WARNING indicates a hazardous situation which, if not avoided, could result in death or serious injury.

⚠ CAUTION

CAUTION used with the safety alert symbol, indicates a hazardous situation which, if not avoided, could result in minor or moderate injury.

⚠ NOTICE

NOTICE is used to address practices not related to personal injury.



⚠ READ INSTRUCTIONS

- Thoroughly read and understand these product instructions before using this tool. Failure to follow all warnings can result in tool damage or serious physical injury.
- Keep these product instructions for future reference.



⚠ WARNING EYE INJURY HAZARD!

- Rapidly rotating surfaces can eject metal particles, dirt and debris at high velocity. Always wear ANSI approved eye protection when operating this tool.



⚠ WARNING HEARING DAMAGE HAZARD!

- This Rockwood Pneumatic Tool emits high sound levels while operating. Use ANSI approved ear protection when operating.



⚠ CAUTION BURSTING HAZARD!

- Do not exceed 90 psi (6.3 bar) of tool inlet pressure. Permanent tool damage and/or explosion could occur and cause personal injury.



⚠ CAUTION INJURY HAZARD!

- This tool uses high-speed, highly abrasive cutting surfaces which can quickly cause injury. Keep fingers and hands away from moving parts when operating. Wear thick, well-fitting work gloves and keep loose clothing, sleeves, cords, jewelry and hair away from moving parts.
- This tool will eject sparks at high speed which can ignite flammable materials or injure others nearby. Do not operate near flammable materials and keep all persons and pets away from the work area.
- Do not force tool or exert excessive side forces on tool while in use as accessories can bend or disintegrate causing them to fragment and eject sharp pieces at high velocity.
- Always make sure the workpiece is securely clamped or anchored to avoid sudden movements which could result in injury.
- Frequently inspect accessories (not included) and tool condition. If damage develops, discontinue tool use immediately and replace damaged accessory. ONLY USE replacement 1/8" or 1/4" shank accessories rated for 22,000 RPM or greater use, otherwise severe injury or death can result in the event of accessory failure.
- Always disconnect tool from air supply when changing accessories to prevent accidental tool starting and potential severe injury.



⚠ CAUTION VIBRATION INJURY HAZARD!

- This tool will vibrate during use! Repeated exposure to vibration may cause physical injury.

SET-UP

- Using a good quality Teflon sealing tape (not included), thread the 1/4" MNPT, Male quick disconnect inlet fitting into the air inlet.

⚠ CAUTION INJURY HAZARD!

To avoid injury, always disconnect air supply to Die Grinder before installing or replacing accessories.

⚠ CAUTION INJURY HAZARD!

To avoid injury, only use accessories rated for High-RPM, (22,000 or greater) use.

TO INSTALL OR SWITCH ACCESSORIES (not included)

- With air supply disconnected, Slide the smaller 14mm end of a Collet Wrench over the flats of the shaft and the larger 19mm end of a Collet Wrench over the flats of the Collet Retainer (**FIG 1**). Loosen the threaded-on Collet Retainer to release the Collet grip on accessory then and pull out the accessory. Replace accessory with one of the same size shank by sliding the shank into the Collet then retighten securely.



TO SWITCH TO A COLLET OF ANOTHER SIZE

- With air supply disconnected, Slide the smaller 14mm end of a Collet Wrench over the flats of the shaft and the larger 19mm end of a Collet Wrench over the flats of the Collet Retainer. Loosen then remove the threaded-on Collet Retainer and place it aside for re-installation (**FIG 2**).
- Withdraw the accessory (if installed) and the Collet.
- Install Collet into bore of Shaft.
- Place accessory (not included) into Collet.
- Replace Collet Retainer and tighten securely with included Wrenches.

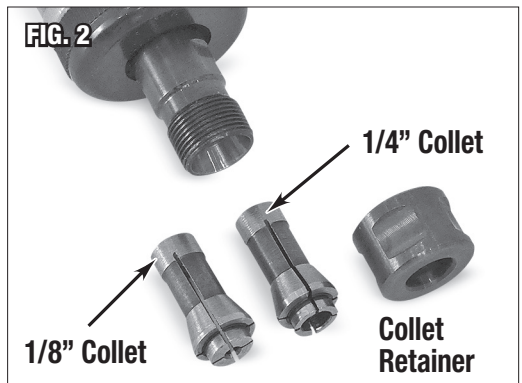

CONNECTION

- Be sure that the air supply to the tool is clean and dry. Moisture in the supply line will quickly damage the motor and valves.
- A minimum 3/8" I.D. air line should be used for optimal performance.

OPERATION

⚠ CAUTION INJURY HAZARD!

To avoid injury, always disconnect air supply to Die Grinder before installing or replacing accessories.

⚠ CAUTION INJURY HAZARD!

To avoid injury, only use accessories rated for High-RPM, (22,000 or greater) use.

- Connect air supply, hold tool securely and depress Paddle to begin rotating action. Speed is regulated by pressure applied to the Paddle.

MAINTENANCE

- Add several drops of air tool oil before each use by dropping directly into the air inlet.
- If tool is to be unused for an extended period, add 10 drops of air tool oil directly to the air inlet, rotate the tool motor by hand several times to distribute the oil throughout the motor and gearbox then store the tool, handle up.

TROUBLESHOOTING

Tool doesn't respond to Paddle depression	Insufficient volume of air (CFM) to operate tool	Verify sufficient air supply to tool. (4 CFM @ 90 PSI minimum requirement).
	Moisture or other contamination in air supply	Check for moisture in air line and tool air inlet.
Tool performance is slow or sluggish	Insufficient volume of air (CFM) to operate tool	Verify sufficient air supply to tool. (4 CFM @ 90 PSI minimum requirement).
	Moisture or other contamination in air supply	Check for moisture in air line and tool air inlet.
	Air Motor is lacking lubrication	Stop use immediately and add air tool oil directly to air inlet.
Tool is excessively noisy/ emits high pitched sound	Air Motor is lacking lubrication	Stop use immediately and add air tool oil directly to air inlet.
Tool vibrates excessively during use	Out of balance condition from damaged accessory	Stop use immediately, check for damage and replace accessory.
	Loose Collet Retainer	Tighten loose Collet Retainer securely.

ADDITIONAL ITEMS

- #11779 8pc Dual-Cut Carbide Burr Set, 1/4in Shank
- #11916 Long Reach Carbide Burr Set, 4 Piece
- #46056 Engine Porting Kit
- #46076 Standard Manifold Smoothing Kit

If you have any questions about the use of this product, please contact

The Eastwood Technical Assistance Service Department: 800.343.9353 >> email: techelp@eastwood.com

PDF version of this manual is available online >> eastwood.com/31825manual

The Eastwood Company 263 Shoemaker Road, Pottstown, PA 19464, USA

US and Canada: 800.343.9353 Outside US: 610.718.8335

Fax: 610.323.6268 eastwood.com