

# **3/8" x 13" PNEUMATIC MINI BELT SANDER**

## **INSTRUCTIONS**



The **ROCKWOOD PNEUMATIC MINI BELT SANDER** is compact and powerful with an adjustable angle sanding arm for ease in grinding and sanding difficult to reach areas. It features a sealed ball bearing drive assembly for smooth, low vibration operation and long life. The precision diecast housing provides a solid foundation and offers ergonomic, one handed operation with a convenient handle mounted paddle trigger.

## CONTENTS

- (1) Mini Belt Sander
- (1) 4 mm Hex-Key Wrench
- (3) 3/8" x 13" Abrasive Belts  
(one installed)
- (1) 1/4" NPT Air Inlet Coupling

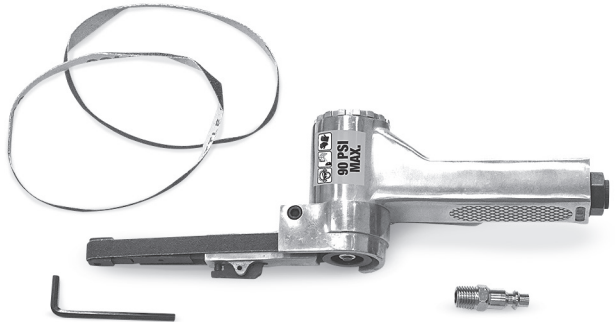

## SPECIFICATIONS

- RPM:** 18,000 free speed
- Air Consumption:** 4 CFM [113 L/m] @90 PSI [6.2 bar]
- Inlet thread size:** 1/4" FNPT
- Required Belt Size:** 3/8" x 13", minimum 18,000 RPM

## REQUIRED FOR USE

- The inlet air supply should have a moisture separator capable of removing all moisture and impurities from the air supply. Moisture in the air supply will cause poor tool performance and damage.
- A suitable regulator must be used to limit incoming air pressure to 90 PSI maximum. Excessive air pressure can cause permanent damage to the unit and possible serious personal injury from bursting.
- For best results, a compressor capable of providing a minimum of 4 CFM @ 90 PSI is recommended for best performance. Less available CFM will negatively affect the performance of the Belt Sander and may overwork the compressor.

# SAFETY INFORMATION

The following explanations are displayed in this manual, on the labeling, and on all other information provided with this product:

## DANGER

DANGER indicates a hazardous situation which, if not avoided, will result in death or serious injury.

## WARNING

WARNING indicates a hazardous situation which, if not avoided, could result in death or serious injury.

## CAUTION

CAUTION used with the safety alert symbol, indicates a hazardous situation which, if not avoided, could result in minor or moderate injury.

## NOTICE

NOTICE is used to address practices not related to personal injury.



### READ INSTRUCTIONS

- Thoroughly read and understand these product instructions before using this tool. Failure to follow all warnings can result in tool damage or serious physical injury.
- Keep these product instructions for future reference.



### WARNING RESPIRATORY HAZARD!

- Dust and fine particulate matter is generated during the sanding process which can contain toxic substances such as lead, silica, solvents and others. Breathing this dust and fine particulate matter can cause many serious respiratory health conditions. Always use NIOSH approved respiratory protection while using this Sander.



### WARNING EYE INJURY HAZARD!

- Rapidly moving abrasive surfaces can eject metal particles, dirt and debris at high velocity. Always wear ANSI approved eye protection when operating this tool.



### WARNING HEARING DAMAGE HAZARD!

- This tool emits high sound levels while operating. Use ANSI approved ear protection when operating.



### **⚠ CAUTION BURSTING HAZARD!**

- Do not exceed 90 psi (6.2 bar) of tool inlet pressure. Permanent tool damage and/or bursting could occur and cause personal injury.



### **⚠ CAUTION INJURY HAZARD!**

- This tool has high-speed, abrasive surfaces which can quickly cause injury. Keep fingers and hands away from moving parts when operating. Wear thick, well-fitting work gloves and keep loose clothing, sleeves, cords, jewelry and hair away from moving parts.
- This tool can eject sparks which can ignite flammable materials. Do not operate near flammable materials and keep all persons and pets away from the work area.
- Always make sure the workpiece is securely clamped or anchored to avoid sudden movements which could result in injury.
- Always disconnect tool from air supply when changing Abrasive Belts or making adjustments to prevent accidental tool starting and potential severe injury.
- Frequently inspect Abrasive Belt and tool condition. If cracks develop, discontinue tool use immediately and replace damaged pad. **ONLY USE** replacement Abrasive Belts rated for 18,000 RPM or greater otherwise severe injury can result in the event of Belt failure.



### **⚠ CAUTION VIBRATION INJURY HAZARD!**

- This tool will vibrate during use! Repeated exposure to vibration may cause physical injury.

## SET UP & CONNECTION

### **⚠ NOTICE**

**Be sure that the air supply to the tool is clean and dry. Moisture in the supply line will quickly damage the air motor and valves.**

**A minimum 3/8" I.D. air line should be used for optimal performance.**

- Wrap white thread sealing tape (not included) around the threads of the included 1/4" Male NPT quick disconnect fitting then thread it into the 1/4" NPT inlet threads of the Belt Sander Body.
- Attach Air Supply to Inlet Fitting.

# OPERATION

## **⚠ WARNING INJURY HAZARD!**

**Disconnect air supply from the tool to prevent accidental starting and potential injury while installing or removing Abrasive Belts.**

- Depress Throttle Paddle inward with fingers to operate tool.
- Keep the broad work surface of the Abrasive Belt parallel to the work surface whenever possible to minimize uneven wear and maximize usable life.
- Always maintain a firm grip while operating tool, do not force but allow the rotational speed of the Abrasive Belt to do the work.
- Be sure that the workpiece is clamped down or held securely to minimize the danger of injury while operating tool.

# ABRASIVE BELT REPLACEMENT

## **⚠ WARNING INJURY HAZARD!**

**Disconnect air supply from the tool to prevent accidental starting and potential injury while installing or removing Abrasive Belts.**

The Abrasive Belts are quickly and easily changed. No tools are required.

The following steps describe how to do this:

- The end of the Abrasive Belt Arm is spring loaded to keep the proper tension on the Abrasive Belts. While holding the tool firmly, push inward on the end of the Abrasive Belt Arm while depressing the Thumb-Lever Latch (**FIG 1**). **NOTE:** The Guide Pin will move inward until it locates under the Latch portion of the Thumb-Lever Latch holding it in the retracted position while the Abrasive Belt is changed (**FIG 2**).
- Pull the worn Abrasive Belt free of the Drive Drum and discard.
- Slide the replacement Abrasive Belt over the Drive Drum and Idle Roller at the end of the Abrasive Belt Arm (**FIG 2**). **NOTE:** Be sure the Abrasive Belt is slid fully over the Guide Bar located on the upper surface of the Abrasive Belt Arm.
- Depress the Thumb-Lever Latch to release the Guide Pin restoring full spring pressure (**FIG 3**).

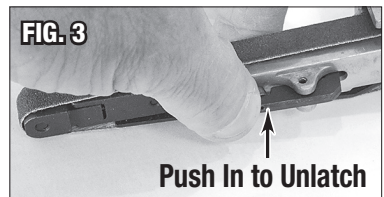
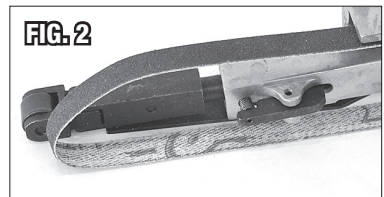
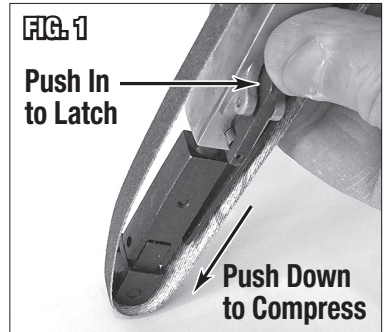

# ADJUSTING SANDING ARM ANGLE

**⚠ WARNING INJURY HAZARD!**

**Disconnect air supply from the tool to prevent accidental starting and potential injury while installing or removing Abrasive Belts.**

- Disconnect air supply from the tool to prevent accidental starting and potential injury while adjusting the Abrasive Belt Arm Angle.
- Using the included 4mm Hex Key, loosen the Angle Adjusting Screw located on the upper side of the Abrasive Arm Assembly (**FIG 4**), rotate Arm to desired position then tighten screw securely.

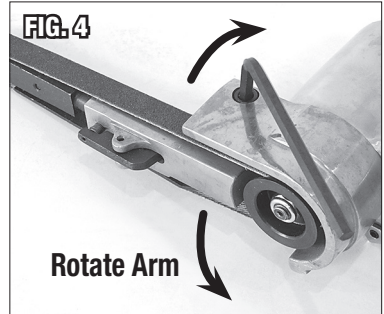

# ADJUSTING BELT TRACKING

**⚠ WARNING INJURY HAZARD!**

**Disconnect air supply from the tool to prevent accidental starting and potential injury while adjusting Belt Tracking.**

- Disconnect air supply from the tool to prevent accidental starting and potential injury while adjusting the Abrasive Belt Tracking. The Tracking Adjustment Screw is located at the outer right side of the Abrasive Arm Assembly (**FIG 5**).
- Using a Phillips screwdriver, turning the screw clockwise (as viewed from the right side) will cause the belt to track left while turning the screw counter-clockwise will cause the belt to track right.



# MAINTENANCE

- Before each use, add a few drops of a quality air tool oil (not included).
- If tool is to be unused for an extended period, add 10 drops of air tool oil directly to the air inlet then store the tool, inlet up.
- With the air supply disconnected, periodically check that the belt is not worn, torn and is tight.

# TROUBLESHOOTING

PROBLEM	CAUSE	CORRECTION
<b>Tool Doesn't Respond to Paddle Depression</b>	Insufficient CFM at tool inlet (4 CFM @ 90 PSI minimum for best results)	Verify sufficient air supply to tool.
	Tool contaminated by moisture	Check for moisture in air line and tool air inlet.
<b>Tool Performance is Slow or Sluggish</b>	Insufficient CFM at tool inlet (4 CFM @ 90 PSI minimum for best results)	Verify sufficient air supply to tool
	Tool contaminated by moisture	Check for moisture in air line and tool air inlet.
<b>Tool Vibrates Excessively During Use</b>	Torn or loose belt	Stop use immediately and check for torn belt.
		Check for loose belt.
<b>Tool Emits Excessive or Unusual Noise During Use</b>	Lack of lubrication in air motor	Stop use immediately and add a quality air tool oil.

# ADDITIONAL ITEMS

**#30661** 5 Pack of 60 Grit, 3/8" x 13" Abrasive Belts

**#30662** 5 Pack of 80 Grit, 3/8" x 13" Abrasive Belts

**#70491** Eastwood Industrial Air Hose, 3/8" x 25'

**#70492** Eastwood Industrial Air Hose, 3/8" x 50'

---

**If you have any questions about the use of this product, please contact**

The Eastwood Technical Assistance Service Department: 800.343.9353 >> email: [techelp@eastwood.com](mailto:techelp@eastwood.com)

PDF version of this manual is available at [eastwood.com](http://eastwood.com)

The Eastwood Company 263 Shoemaker Road, Pottstown, PA 19464, USA

800.343.9353 [eastwood.com](http://eastwood.com)