

*Eastwood*<sup>®</sup>

DO THE JOB RIGHT.<sup>®</sup>

Item #32190

# 1/4" DRIVE MICROMETER TORQUE WRENCH

20-100 IN-LB./1.7-11.9 NM.

INSTRUCTIONS



The **1/4" DRIVE MICROMETER TORQUE WRENCH** is a top-quality, precision unit built for professional use. It features permanent laser-etched calibrations that are marked in both in-lb./Nm., and functions in both directions. It has a CRV-steel head with Chro-Mo steel drive components for maximum durability. The 20 to 100 in-lb./1.7 to 11.9 Nm. range is perfect for all light automotive applications.

## CONTENTS

- (1) Torque Wrench
- (1) Torque Calibration Certificate
- (1) Heavy Duty Blow Molded Storage Case

## SPECIFICATIONS

20 to 100 in-lb./1.7 to 11.9 Nm. Range in 1 in-lb. increments.

60 tooth ratchet mechanism.

+/- 6% Accuracy.

Dual direction torque reading capability.

## SAFETY INFORMATION

The following explanations are displayed in this manual, on the labeling, and on all other information provided with this product:

### **DANGER**

DANGER indicates a hazardous situation which, if not avoided, will result in death or serious injury.

### **WARNING**

WARNING indicates a hazardous situation which, if not avoided, could result in death or serious injury.

### **CAUTION**

CAUTION used with the safety alert symbol, indicates a hazardous situation which, if not avoided, could result in minor or moderate injury.

### **NOTICE**

NOTICE is used to address practices not related to personal injury.

# SAFETY INFORMATION



## **⚠ READ INSTRUCTIONS**

- Thoroughly read and understand these product instructions before using this Torque Wrench.
- Keep these product instructions for future reference.



## **⚠ WARNING**

- This tool creates high amounts of leverage while in operation. Wear ANSI approved eye protection and heavy-duty work gloves at all times while operating.
- Over torquing can cause part failure.
- Read and understand all manufacturer's instructions for the vehicle or object on which the fastener is being torqued. Failure to do so could cause damage or personal injury.



## **⚠ CAUTION**

- Do not use for loosening and installing fasteners. Use only for the final tightening of a fastener to the recommended torque.
- Do not extend handle by use of a pipe or other means. Doing so may cause tool damage or personal injury.
- Inspect before every use, if tool appears damaged do not use.
- Ensure all sockets and ancillary tools used in conjunction with this torque wrench are rated to handle the intended torque setting.

# SETTING THE TORQUE WRENCH

- To unlock, pull the Lock Collar towards the knurled hand grip (**FIG 1**).
- While holding the Lock Collar back, rotate the handle clockwise to the desired torque value. To select the desired torque, turn the handle until the 0 aligns with the major graduation (**FIG 2**), then continue turning until the desired minor graduation is in line with the barrel center line (**FIG 3**).
- Release the lock collar. Rotate the grip slightly until the lock collar springs forward and locks.
- The wrench is now set for operation.

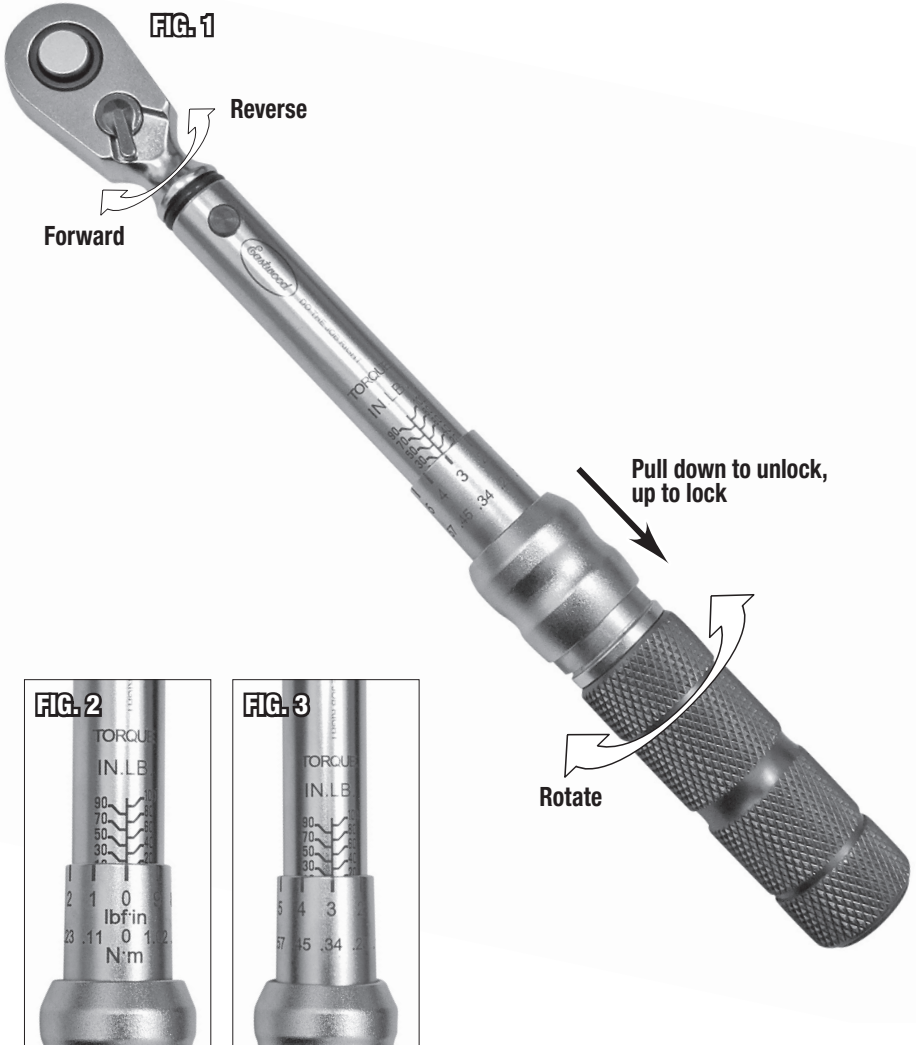

# SETTING THE TORQUE WRENCH IF USING BOXED END EXTENSIONS

If a box end extension is being used the effective lever length will change with the addition of the extension. Use the equations below to compute the torque setting adjustment necessary:

**NOTE:** Socket Drive Extensions are axially in line with the drive mechanism of the torque wrench and do not require adjustments.

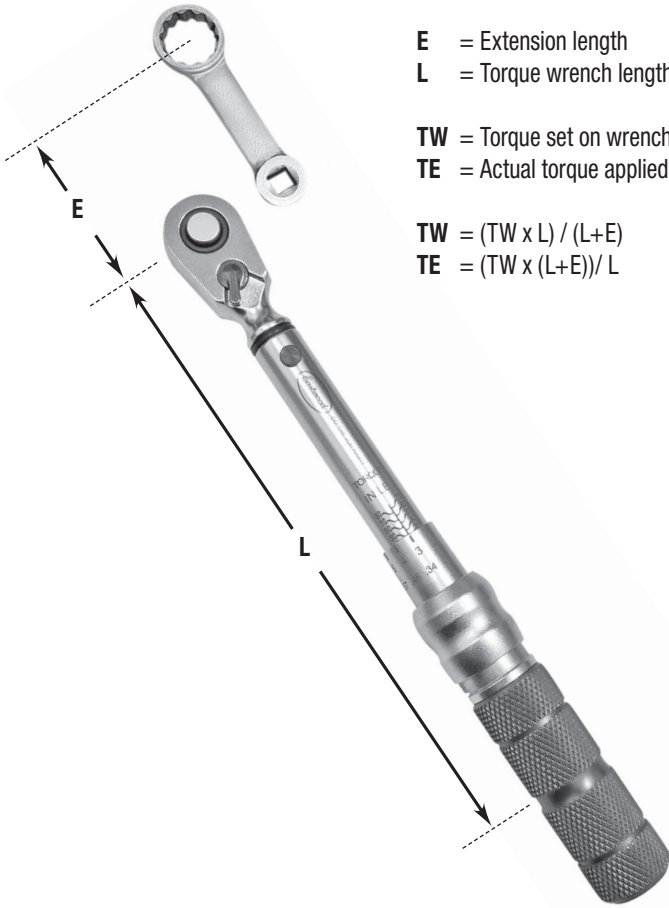

**E** = Extension length  
**L** = Torque wrench length

**TW** = Torque set on wrench  
**TE** = Actual torque applied with extension in place

$TW = (TW \times L) / (L+E)$   
 $TE = (TW \times (L+E)) / L$

# TORQUE WRENCH OPERATION

- Set torque wrench to the desired value (See section: Setting the Torque Wrench).
- Move the Forward/Reverse Lever on the Head to the desired direction (to the Left for Forward or to the Right for Reverse).
- Install appropriate socket and secure the socket on the fastener.
- Center hand on the handle grip and apply a steady force in the desired direction until a click is felt or heard. **Immediately stop pulling once the click is felt or heard.** The fastener is now torqued to the desired setting.

## **⚠ NOTICE**

**After each use, pull lock collar and rotate handle counterclockwise until the torque wrench is at its lowest setting. This will release internal tension and allow the torque wrench to stay in calibration as long as possible.**

# MAINTENANCE

- Before each use inspect the condition of the tool for damage.
- Always place the Torque Wrench in the supplied Storage Case to prevent damage.
- After each use ensure that the wrench is set to its lowest torque setting.
- Have the Torque Wrench periodically calibrated by a local certified metrology lab to maintain accuracy.
- If storing, coat tool with a rust preventative coating such as a light machine oil.



---

**If you have any questions about the use of this product, please contact**

The Eastwood Technical Assistance Service Department: 800.343.9353 >> email: [tech@eastwood.com](mailto:tech@eastwood.com)

PDF version of this manual is available at [eastwood.com](http://eastwood.com)

The Eastwood Company 263 Shoemaker Road, Pottstown, PA 19464, USA

800.343.9353 [eastwood.com](http://eastwood.com)