

ALC™

Soda Blast Retrofit Kit™ for ALC® Abrasive Blast Units



P/N 40416
Instructions

Division of S&H Industries, Inc.
5200 Richmond Road
Cleveland, Ohio 44146
Toll Free 800-253-9726
www.shindustries.com

Before You Begin

Do not use this product or its related pressure blasters until you have read and understand both manuals contents and warnings. These warnings are included for the health and safety of the operator. Keep this manual for future reference.

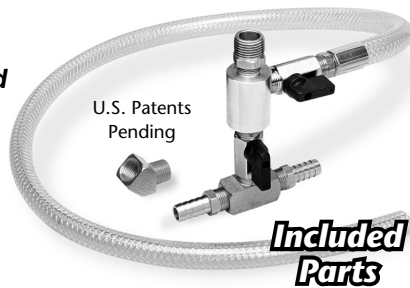

IMPORTANT WARNING: This conversion should only be performed by those with a good working knowledge of pneumatic fittings. Failure to properly seal or over tightening the NPT fittings can lead to component failure which could result in sudden air pressure release and cause serious injury.

OBSERVE THE FOLLOWING SAFETY PRECAUTIONS & WARNINGS

- Always wear full eye, hearing, skin and respiratory protection when operating the ALC Soda Blasting Retrofit Kit™.
- Dust may irritate or damage eyes and respiratory system, noise emissions may damage hearing and abrasive material ejected at high pressure can cause injury.
- Required safety equipment includes:
 - A NIOSH N95 or equivalent approved dust mask.
 - Safety goggles or blasting hood.
 - Hearing protection.
 - Canvas, heavy rubber or leather abrasive blasting long gloves.

IMPORTANT WARNINGS: Although the Bicarbonate of Soda (Baking Soda) blasting media itself is safe in most situations, appropriate care should be taken when using or disposing as some removed paints and coatings may contain some levels of hazardous materials such as lead, zinc chromate, etc. **Additional or different protection may be required in the presence of these substances for both the user and others within the immediate area.**

- Read, fully understand and refer to the main Instruction Manual supplied with your Abrasive Blasting Unit fully before beginning this conversion and operation.
- Keep people, children, pets, and valuable property away from nozzle discharge to avoid injury or unwanted damage.
- Be sure to release all pressure and drain remaining media from Abrasive Blaster if present, before beginning conversion process. The media will flow from the threaded hole on the underside of the tank when the existing fitting assembly is removed.

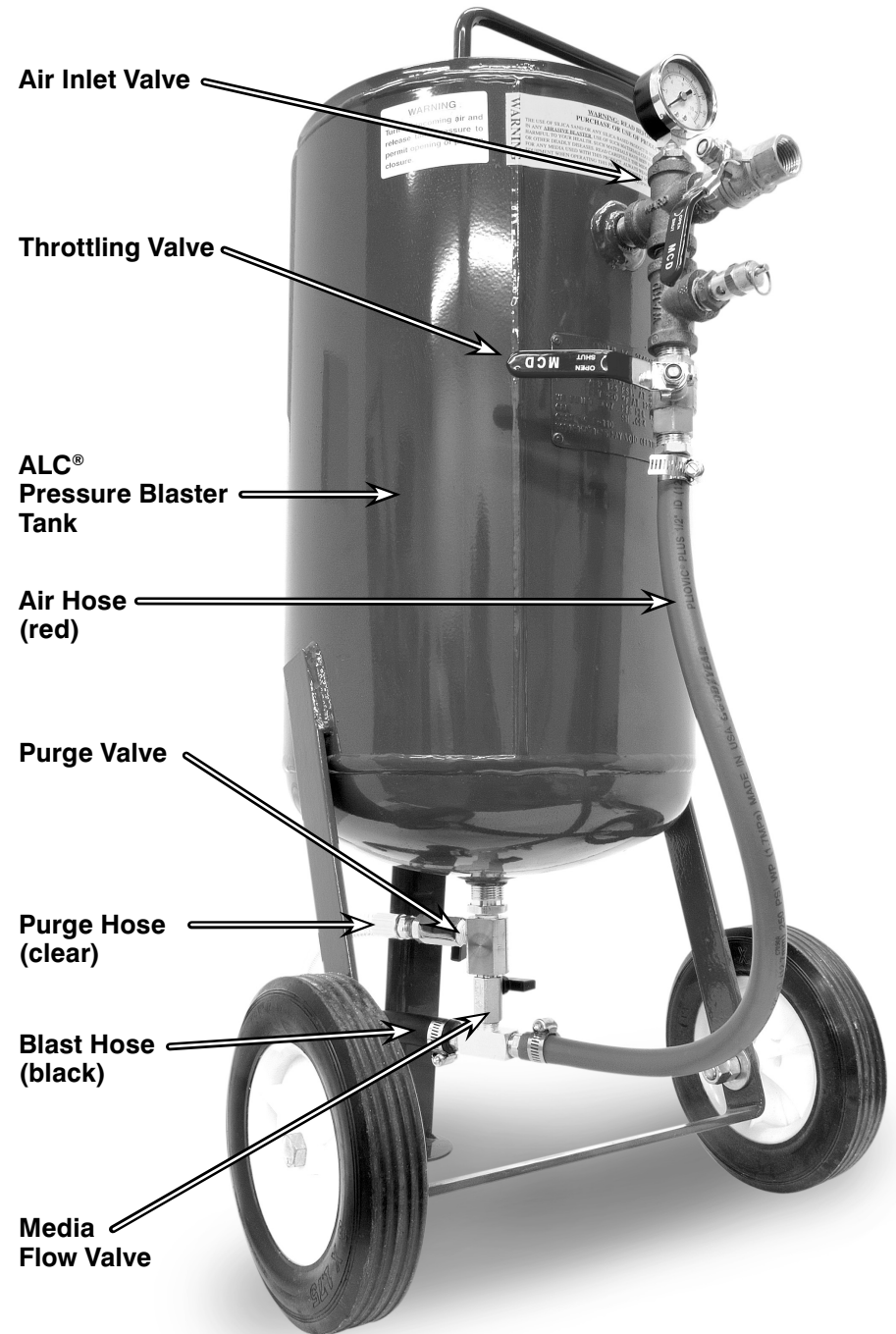

Disassembly For Conversion

1. Disconnect air supply to unit and release tank pressure if any.
2. Loosen and remove Red Air Hose from the Air Inlet Manifold.
3. Loosen and remove Red Air Hose from port in the Abrasive Outlet Manifold.
4. Remove Black Blast Nozzle Hose from Abrasive Outlet Manifold by removing hose clamp and pulling hose free from barbed fitting.
5. Loosen and remove entire Abrasive Outlet Manifold and Ball Valve assembly from bottom of tank. (See Fig 1).
6. Remove all shreds of thread sealing tape and inspect fittings and threads for cracks or damage.
7. Completely remove all previously used media. Failure to do so may result in damage to parts intended for soda blasting.

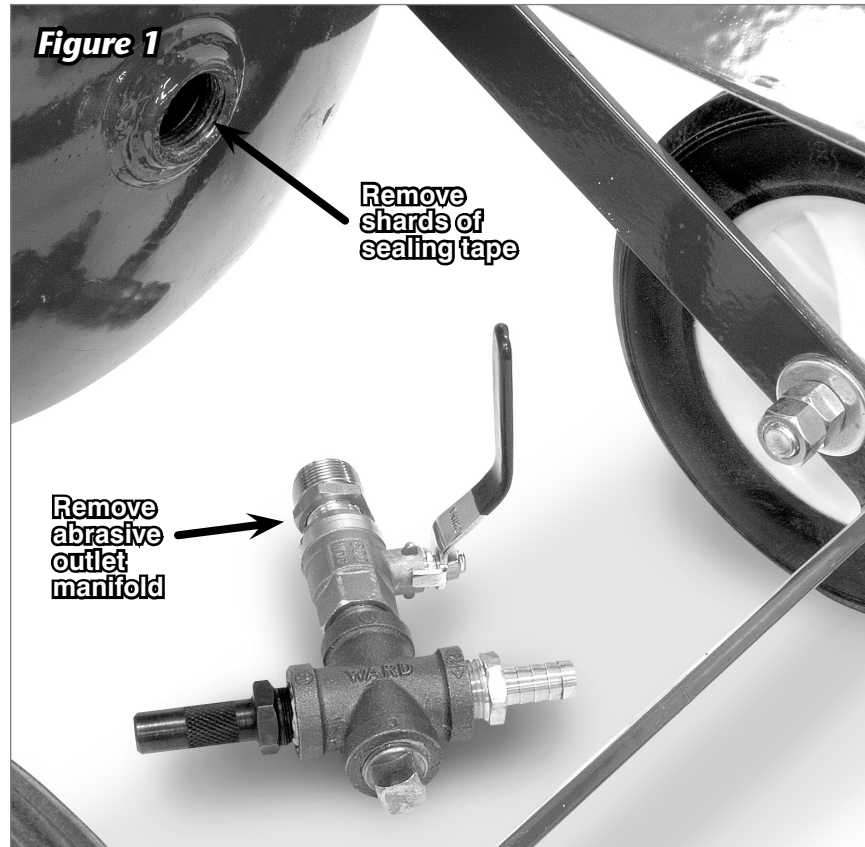

Assembly For Conversion

1. Remove protective plastic cap from male threads on top of ALC Soda Blast Retrofit Kit™ Assembly.
2. Thread the assembly into the bottom of the tank and tighten with a suitable wrench. (Fig. 2). Note: barbed fitting & Clear Purge Hose should face forward (Fig. 2).
3. Place the Red Air Hose onto the rear-facing Barbed Fitting and tighten with existing hose clamp.
4. Re-attach the Red Air Hose onto the Air Inlet Manifold and tighten with a suitable wrench.
5. Place the Black Blast Nozzle Hose over the forward facing Barbed Fitting and tighten with existing hose clamp.
6. Your blaster is now completely retrofitted and ready to be filled with Soda Blasting Media.

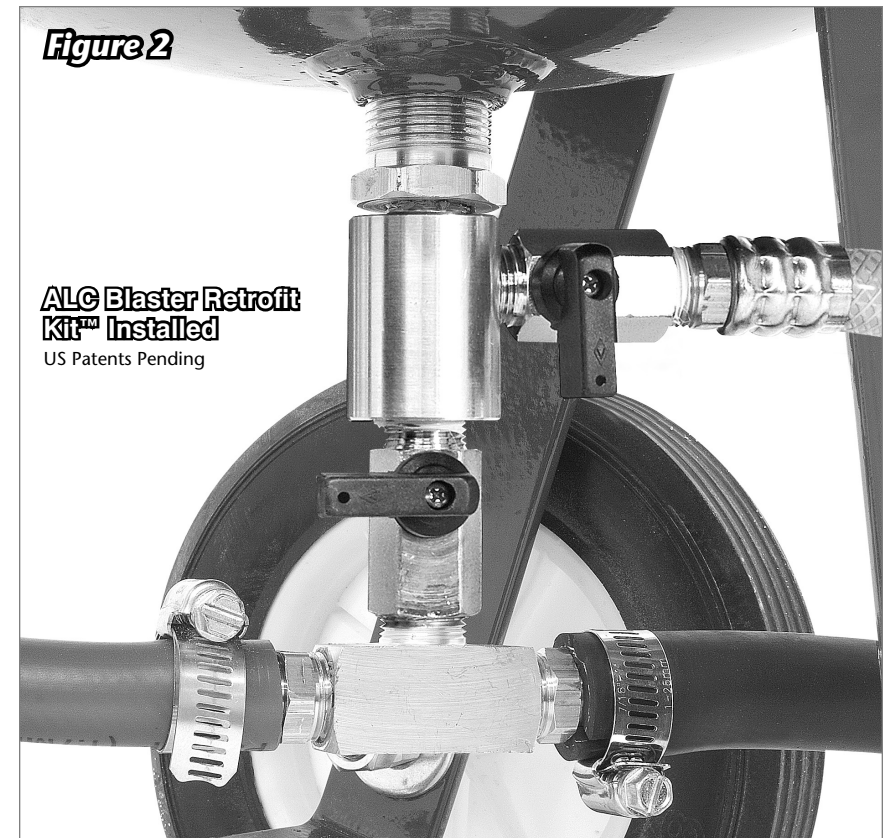

IMPORTANT NOTE:

Soda Blasting Media is highly susceptible to moisture absorption which will cause clumping and erratic operation. To insure proper function, it is imperative to have an effective moisture filter and or desiccant system in the air supply immediately before the Air Inlet. Be sure to drain any moisture captured in the moisture filter before and after each use. Failure to do so may cause “caking” of media and complete blockage of equipment.

Operation

1. Refer to the specific safety and operation information in the instruction manual included with your Pressure Blaster before continuing.
2. Carefully fill the unit per Blaster Instructions using a screen sifter and funnel. Note: a suitable screen sifter such as an ALC #41908 must be used to capture any clumps present in the bag of media.
3. Close all four valves and connect the air supply. DO NOT EXCEED 125 PSI. For best results, begin with a blaster inlet pressure of 80 to 90 PSI. To avoid media clumping or caking, be certain to have a clean, moisture free air supply that includes an effective moisture filter or desiccant system.
4. Pull up on the fill lid and open the Inlet Air Supply Valve slowly and carefully while checking for leakage.
5. Slowly open the Throttling Valve (Fig. 3) to the 1/2 position while checking for leakage. Note: This valve will require fine tuning to provide optimal media flow based on media formulation, air pressure and desired volume.
6. Slowly open the Media Flow Valve to the full position while checking for leakage.
7. You may now direct the nozzle toward your work and depress the Nozzle Discharge Lever. Note: Some slow, pulsing discharges of media can be expected until the flow begins.
8. Once a steady flow of media is observed, begin by holding the nozzle 6” to 12” from the work surface at a 30-45 degree angle for best results.
9. Hold the stream against the work until it abrades through the coating revealing an edge.
10. Use the stream as a “wedge” working at the edge to quickly remove the coating.
11. At this point you can vary the position of the Throttling Valve (Fig. 3) from the initial 1/2 open starting setting to achieve an optimum air/media ratio. Note: As there are many variables affecting the flow

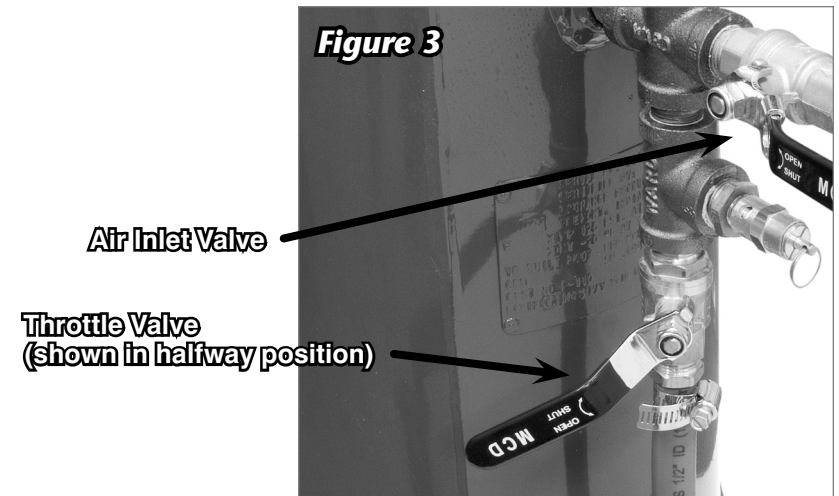

such as media formulation, hardness of coating, air volume, air pressure and atmospheric conditions, this process requires a bit of “trial and error” by experimenting with distance, angle and throttle position. You will quickly become proficient at determining the ideal settings.

12. When refilling the tank becomes necessary, first shut off the Inlet Air Supply Valve, The Throttle Valve and The Flow Valve. For safety, disconnect the air supply. Next, open the Purge Valve to release all tank pressure. You may then refill per filling instructions in your users manual.
13. It is advisable to drain all unused media when completing work as any moisture present in the tank will drain to the bottom of the tank and can create a solid “cake” with the media, requiring complete disassembly of the apparatus at the bottom of the tank. Note: Failure to properly seal or over tightening fittings can lead to component failure which could result in sudden air pressure release and cause serious injury.
14. To drain unused media from the tank, place the open end of The Clear Purge Hose into a suitable vessel such as a large bucket or box with closed seams and cover with a blanket. Using extreme care, slowly open the Purge Valve and direct the stream of media into the vessel.
15. **WARNING: Do not use this equipment in any area that may be considered hazardous or where flammable gases, vapors or liquids are present. Static electricity can be created by use of this equipment. Failure to comply with this warning may cause an explosion resulting in a serious injury.**

Troubleshooting

1. The most common problem encountered with Soda Blasting is clumping of media due to moisture contamination. If media stops flowing, stop all work and “burp” (quickly open and close) the Purge Valve allowing a minimal discharge of media from the Clear Purge

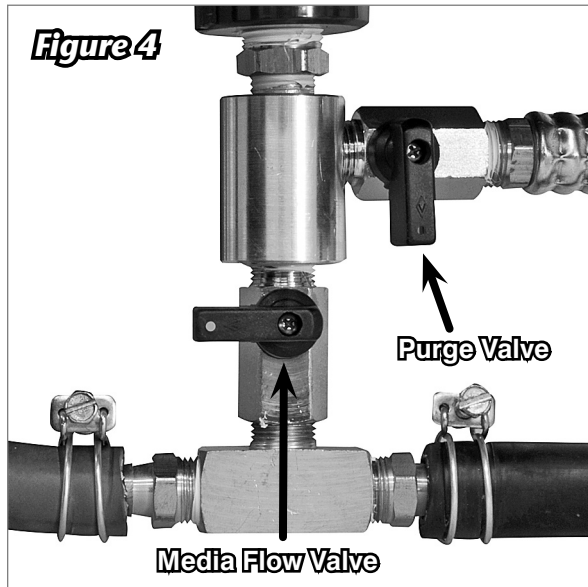

- Hose. Be certain to direct the discharge to a safe area. Placement of the hose in a cardboard box covered with a blanket is strongly recommended.
2. If a purge fails to restore flow, stop all work and close the Throttle Valve (Fig. 3) fully. You can then depress the Nozzle Discharge Lever several times which will discharge a quantity of media under tank pressure clearing the clumping.
 3. It is strongly advisable to drain all unused media when completing work as any moisture present in the tank will drain to the bottom of the tank and can create a solid “cake” with the media. Should this occur, it will require complete disassembly of the apparatus at the bottom of the tank for cleaning.
 4. If results become erratic or undesirable, remember that there are many variables affecting the flow such as media formulation, hardness of coating, air volume, air pressure and atmospheric conditions, this process requires a bit of “trial and error” by experimenting with distance, angle and throttle position. By adjusting Throttle Valve (Fig. 3) position between 1/2 and full open and varying the distance of the nozzle to work surface along with the angle, optimal performance can quickly be restored. Refer to steps 8 through 11 in the Operation section for more information.

Work Area Prep and Cleanup

1. Soda Blasting generates a considerable amount of fine bicarbonate of soda dust. If working outdoors, be aware of wind direction, open windows, vegetation, vehicles, pets, people and property. It may be helpful to place a fine mist, garden hose lawn sprinkler downwind of the blasting site to suppress dust generation.
2. It is best to cover the work area under and surrounding the vehicle or object to be stripped with a 3 mil or thicker plastic sheet material to assist in cleanup. You may also wish to tape up window seals and other areas to keep unwanted dust out of a vehicle.
3. Bicarbonate of Soda itself is virtually harmless to the environment however, in higher concentrations; it may cause browning of vegetation. Care should be taken to avoid depositing excess soda on plant life.
4. When finished, the plastic sheeting with the used soda media can be rolled up and disposed of, reducing sweep up time. The remainder should be swept up and disposed of. Any remaining soda residue is water soluble and can be hosed away. Important Note: Although the Bicarbonate of Soda blasting media itself is safe in most situations, appropriate care should be taken when using or disposing as any removed paint or coating can contain some levels of hazardous materials such as lead, zinc chromate, etc.

Helpful Tips

- Soda Blasting leaves behind a thin protective film which, if left untouched, will prevent surface rust from forming on bare steel surfaces for up to 6 weeks or even longer if stored in a dry, protected area. This film must be removed before painting by wiping down with water dampened Microfiber cloths or suitable lint-free towels. It is best to soak the cloth, wring out excess water, wipe off soda residue, rinse often and immediately follow up with a dry lint-free towel.
- Any soda media left in body seams or crevices can be removed with a small shop vacuum and a fine tipped blow gun. Be sure to wipe surrounding areas as described above.

Suggested Items

- ALC Blast Media Screen Sifter #41908.
- Considerable noise is generated during the blasting process. Suitable earphones or other hearing protection (such as our Economic Ear Muffs #VT9800) is strongly recommended.
- A garden hose and water supply.
- Teflon® thread sealing tape available at any home or automotive supply store.
- A roll or several packages of 3 mil, or thicker, plastic sheet material for used media containment, vegetation protection and vehicle dust sealing.
- #40127 20 lb. Bicarbonate of Soda Blast media.
- #40130 50 lb. Bicarbonate of Soda blast Media.
- #40019 Standard Hood.
- #40024 Standard Hood with Bump Cap.
- #40339 Deluxe Hood.
- #40556 Deluxe Industrial Hood.
- #40022 Standard Blast Gloves.
- #40023 Premium Blast Gloves.

Air Supply and Media Consumption

IMPORTANT NOTE:

This data is approximate and is presented for comparison use. Due to the many variables such as; compressor capacity, air line size, grade of media used, coating thickness and hardness, individual results will vary.

Nozzle Size	CFM @ 80 PSI	Approximate Media Usage	Area
3/32"	7	45 lbs/hr	200 sq. in./hr
1/8"	15	70 lbs/hr	325 sq. in./hr
5/32"	25	100 lbs/hr	390 sq. in./hr
3/16"	40	160 lbs/hr	440 sq. in./hr
1/4"	80	320 lbs/hr	560 sq. in./hr
5/16"	125	650 lbs/hr	900 sq. in./hr

Disclaimer of Warranties. S & H Industries, Inc. (“Seller”) makes no warranties with respect to any goods delivered to Buyer or users except as specifically set forth within this manual. S & H INDUSTRIES, INC. MAKES NO IMPLIED WARRANTIES OF MERCHANTABILITY OR FITNESS FOR A PARTICULAR PURPOSE WITH RESPECT TO ANY OF THE GOODS, AND S & H INDUSTRIES, INC. EXPRESSLY DISCLAIMS ANY IMPLIED WARRANTIES AGAINST INFRINGEMENT. S & H INDUSTRIES, INC. WARRANTIES SHALL NOT APPLY TO ANY DAMAGE OR NON-CONFORMITY RESULTING FROM THE NEGLIGENCE OF IMPROPER ASSEMBLY OR USE OF ANY GOODS BY USERS OR BUYER OR ITS EMPLOYEES OR AGENTS, OR FROM ALTERATION OR ATTEMPTED REPAIR BY ANY PERSON OTHER THAN S & H INDUSTRIES, INC. ALL USES, REPAIRED, MODIFIES OR ALTERED ITEMS ARE PURCHASED AS-IS AND WITH ALL FAULTS.

LIMITED WARRANTY

S & H Industries, Inc. warrants this product to be free from defects in materials or workmanship for two years after the date of original purchase.

If the product should become defective within that warranty period, we will repair or replace it (at our option) free of charge including return transportation to you provided you deliver it prepaid to S & H Industries, Inc., 5200 Richmond Road, Bedford Hts., Ohio 44146. This warranty does not include damage resulting from accident, abuse or misuse of the product. Nor does it apply to parts subject to abrasive wear, i.e., nozzles, air jets, seal blocks, valves, hose connections and hoses.

Implied warranties including those of merchantability and fitness for a particular purpose are excluded to the extent permitted by law, and any and all implied warranties are excluded. This is the exclusive remedy and liability for consequential damages under any and all warranties are excluded to the extent exclusion is permitted by law.

If you have any questions about the use of this product,
please contact S&H Industries:

1-800-253-9726 email: service@shindustries.com

S&H Industries

5200 Richmond Road, Cleveland, Ohio 44146, USA

Toll Free: 800-253-9726

www.shindustries.com