

*Eastwood*<sup>®</sup>

DO THE JOB RIGHT.<sup>®</sup>

Item #55001

# CONCOURS<sup>®</sup> PAINT GUN STAND

## INSTRUCTIONS



Paint Gun and Filter sold separately

The **EASTWOOD CONOURS PAINT GUN STAND** is a unique modular design that can be easily reconfigured to accept just about any size or shape paint gun or gun cup. A convenient upper hoop is designed to support paint strainers while filling the Gun Cup. Constructed of solvent and paint resistant Polybutylene Terephthalate (PBT), it is designed for years of service.

## SAFETY INFORMATION

The following explanations are displayed in this manual, on the labeling, and on all other information provided with this product:

### **⚠ DANGER**

DANGER indicates a hazardous situation which, if not avoided, will result in death or serious injury.

### **⚠ WARNING**

WARNING indicates a hazardous situation which, if not avoided, could result in death or serious injury.

### **⚠ CAUTION**

CAUTION indicates a hazardous situation which, if not avoided, could result in minor or moderate injury.

### **⚠ NOTICE**

NOTICE is used to address practices not related to personal injury.

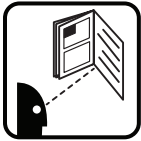

### **⚠ READ INSTRUCTIONS**

- Thoroughly read and understand these product instructions before using this equipment. Failure to follow all warnings can result in tool damage or serious physical injury.
- Keep these product instructions for future reference.



### **⚠ WARNING SHOCK HAZARD!**

- Check for possible interference with electrical lines, other utilities or other unseen obstructions before drilling or driving screws into a surface for mounting.



### **⚠ WARNING INJURY HAZARD!**

- Do not mount in a location where the Paint Gun Stand may become an obstruction where head or bodily contact could cause injury.

### **⚠ CAUTION INJURY HAZARD!**

- This unit must be solidly placed or securely mounted to prevent spilling which could cause personal injury and property damage.

# ASSEMBLY (FIG 1)

- Slide the L Shape Bracket [B] into the recess of the Base [A] so that all 4 holes are aligned in each (FIG 2).
- Push the end of the Paint Gun Support [G] into the recess of the Base [B] (FIG 3).
- Slip the Cup Holder Bracket [B1] down over the upright of [B] (FIG 3).
- Slide the Extension Rod [C] over the pin of [B] (FIG 4) (If needed).
- Place the recess of the "O" Shape Frame [D] over the pin of [C] (FIG 5) (if needed).
- Insert the post of either the Large Cup Holder [E] or Small Cup Holder [F] into the open recess of the Cup Holder Bracket [B1] (FIG 6).

FIG. 1

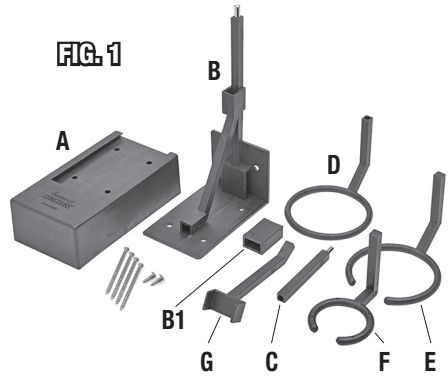

PARTS LIST

PARTS CODE	DESCRIPTION	QTY
A	BASE	1
B	L SHAPE BRACKET	1
B1	CUP HOLDER BRACKET	1
C	EXTENSION ROD	1
D	O SHAPE FRAME	1
E	LARGE CUP HOLDER	1
F	SMALL CUP HOLDER	1
G	PAINT GUN SUPPORT	1

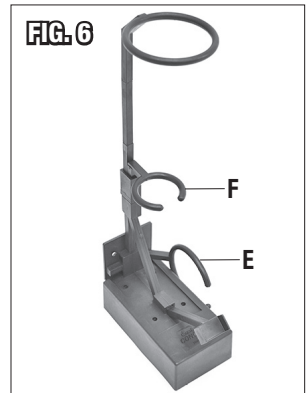
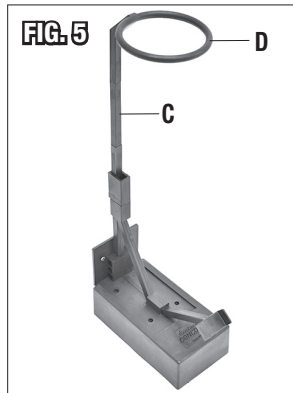
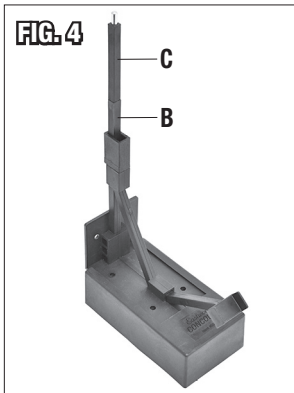
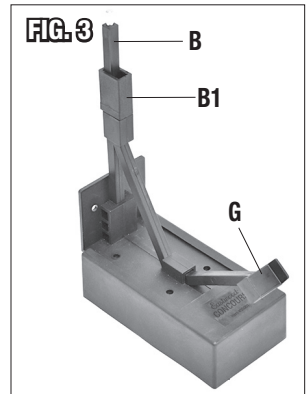
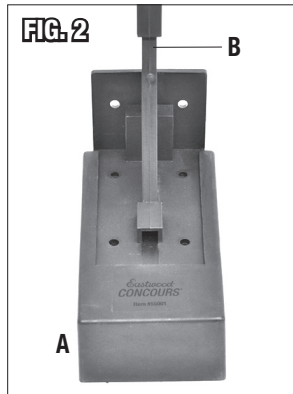

# INSTALLATION

- For best performance, the Paint Gun Stand should be mounted in a level position on a wall, cabinet, shelf, workbench etc, capable of holding 10lbs. [4.5kg.] plus pulling stresses from usage. The use of the included screws for attachment to a structural member is highly recommended.
- If mounting to a horizontal surface, it should be placed near the edge to allow clearance for an attached air supply hose.
- The Eastwood Concours Paint Gun Stand can be mounted one of two ways: Four holes of the Base **[A]** using the included 4 Long Screws to a horizontal surface or with the back plate of the “L” Bracket **[B]** to a wall or other vertical surface using the 2 Short Screws.

**NOTE:** If mounting to a studded wall with drywall or other thicker covering it is recommended to use two of the longer screws to mount into the stud.

# USE

- Select the needed Cup Holder **[E]** or **[F]** based on the Gun and Cup size.
- Set the Paint Gun into the Stand with the air cap oriented toward the back of the Stand and the neck of the Gun Cup cradled in the Cup Holder **[E]** or **[F]** (**FIG 7**).
- If a paint strainer is to be used, set it carefully into the large, “O” Shape Frame **[D]** (**FIG 8**).
- Any unused attachments **[C]**, **[E]** or **[F]** can be stored by pushing the ends into various open receptacle areas of the assembly.



---

**If you have any questions about the use of this product, please contact**

The Eastwood Technical Assistance Service Department: 800.343.9353 >> email: tech@eastwood.com

PDF version of this manual is available at eastwood.com

The Eastwood Company 263 Shoemaker Road, Pottstown, PA 19464, USA

800.343.9353 eastwood.com