

Eastwood®

DO THE JOB RIGHT.®

# BUFF MOTOR INSTRUCTIONS



#64732 1 HP Dual-Speed Professional Buff Motor



#64733 1/2 HP Professional Buff Motor

The **EASTWOOD BUFF MOTORS** are designed and built to high quality standards using precision components. The balanced shaft and armature is supported by substantial roller bearings while the capacitor start motor allows fast, efficient starting and high torque. Extra-long shaft length provides obstruction free working room around the motor housing.

## CONTENTS

- (1) Buff Motor Unit (A)
- (1) Special, Left-Hand Threaded Arbor Nut (for Left Side Shaft Threads) (B)
  - 5/8"-11 x 2 for #64733
  - 3/4"-10 for #64732
- (1) Standard, Right-Hand Threaded Arbor Nut (for Right Side Shaft Threads) (C)
  - 5/8"-11 for #64733
  - 3/4"-10 for #64732
- (4) Buff Wheel Support Flanges (D)
- (2) Short Shaft Spacers (E)
- (2) Long, Shaft Spacers (F) (included only with #64732, 1 HP, Dual-Speed Motor)
- (1) Buffing and Finishing Instructions and How-To Guide (Eastwood #13143Q)

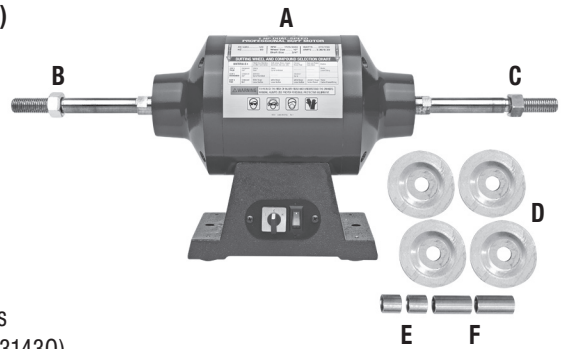
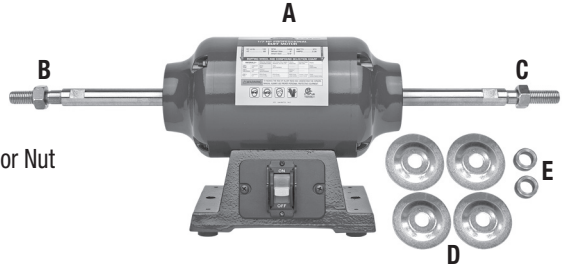

## SPECIFICATIONS

### #64733, 1/2 HP MOTOR

**120 VAC, 60hz, 3.36Amps, 370 Watts**

**Free Speed RPM:** 3450

**Arbor Size:** 5/8"

**Buff Wheel Capacity:** 8"

### #64732, 1 HP, DUAL-SPEED MOTOR

**120 VAC, 60hz, 3.36/6.30 Amps, 370/750 Watts**

**Free Speed RPM:** 1725/3450

**Arbor Size:** 3/4"

**Buff Wheel Capacity:** 10"

# IMPORTANT SAFETY INFORMATION

The following explanations are displayed in this manual, on the labeling, and on all other information provided with this product:

## **DANGER**

DANGER indicates a hazardous situation which, if not avoided, will result in death or serious injury.

## **WARNING**

WARNING indicates a hazardous situation which, if not avoided, could result in death or serious injury.

## **CAUTION**

CAUTION indicates a hazardous situation which, if not avoided, could result in minor or moderate injury.

## **NOTICE**

NOTICE is used to address practices not related to personal injury.

## GENERAL SAFETY RULES

### **WARNING**

Read all instructions. Failure to follow all instructions listed below may result in electric shock, fire and/or serious injury. The term “power tool” in all of the warnings listed below refers to your mains-operated (corded) power tool or battery-operated (cordless) power tool.

### 1) WORK AREA SAFETY

- a) Power tool plugs must match the outlet. Never modify the plug in any way. Do not use any adapter plugs with earthed (grounded) power tools. Unmodified plugs and matching outlets will reduce risk of electric shock.
- b) Avoid body contact with earthed or grounded surfaces such as pipes, radiators, ranges and refrigerators. There is an increased risk of electric shock if your body is earthed or grounded.
- c) Do not expose power tools to rain or wet conditions. Water entering a power tool will increase the risk of electric shock.
- d) Do not abuse the cord. Never use the cord for carrying, pulling or unplugging the power tool. Keep cord away from heat, oil, sharp edges or moving parts. Damaged or entangled cords increase the risk of electric shock.
- e) When operating a power tool outdoors, use an extension cord suitable for outdoor use. Use of a cord suitable for outdoor use reduces the risk of electric shock.

## 2) PERSONAL SAFETY

- a) Stay alert, watch what you are doing and use common sense when operating a power tool. Do not use a power tool while you are tired or under the influence of drugs, alcohol or medication. A moment of inattention while operating power tools may result in serious personal injury.
- b) Use safety equipment. Always wear eye protection. Safety equipment such as dust mask, non-skid safety shoes, hard hat, or hearing protection used for appropriate conditions will reduce personal injuries.
- c) Avoid accidental starting. Ensure the switch is in the off-position before plugging in. Carrying power tools with your finger on the switch or plugging in power tools that have the switch on invites accidents.
- d) Remove any adjusting key or wrench before turning the power tool on. A wrench or a key left attached to a rotating part of the power tool may result in personal injury.
- e) Do not overreach. Keep proper footing and balance at all times. This enables better control of the power tool in unexpected situations.
- f) Dress properly. Do not wear loose clothing or jewelry. Keep your hair, clothing and gloves away from moving parts. Loose clothes, jewelry or long hair can be caught in moving parts.
- g) If devices are provided for the connection of dust extraction and collection facilities, ensure these are connected and properly used. Use of these devices can reduce dust-related hazards.

## 3) POWER TOOL USE AND CARE

- a) Do not force the power tool. Use the correct power tool for your application. The correct power tool will do the job better and safer at the rate for which it was designed.
- b) Do not use the power tool if the switch does not turn it on and off. Any power tool that cannot be controlled with the switch is dangerous and must be repaired.
- c) Disconnect the plug from the power source and/or the battery pack from the power tool before making any adjustments, changing accessories, or storing power tools. Such preventive safety measures reduce the risk of starting the power tool accidentally.
- d) Store idle power tools out of the reach of children and do not allow persons unfamiliar with the power tool or these instructions to operate the power tool. Power tools are dangerous in the hands of untrained users.
- e) Maintain power tools. Check for misalignment or binding of moving parts, breakage of parts and any other condition that may affect the power tools operation. If damaged, have the power tool repaired before use. Many accidents are caused by poorly maintained power tools.
- f) Keep cutting tools sharp and clean. Properly maintained cutting tools with sharp cutting edges are less likely to bind and are easier to control.
- g) Use the power tool, accessories and tool bits etc., in accordance with these instructions and in the manner intended for the particular type of power tool, taking into account the working conditions and the work to be performed. Use of the power tool for operations different from those intended could result in a hazardous situation.

# ADDITIONAL SAFETY INFORMATION



## **⚠ READ INSTRUCTIONS**

- Thoroughly read and understand this manual before using.
- Save for future reference.



## **⚠ WARNING HEALTH HAZARD!**

- Dust and fine particles are generated while buffing which can contain hazardous or toxic substances. Breathing this dust can cause many serious respiratory health conditions. Always use NIOSH approved respiratory protection while using this Buff Motor.
- The rotating Buff Wheel can suddenly grab the work piece with great force causing serious injury. Keep fingers from behind or under work piece while Buffing.



## **⚠ WARNING INJURY HAZARD!**

- Do not apply excessive force to Buff Motor while in use. Always make sure the workpiece or material being buffed is held securely and work is done only in the lower front quadrant of the Buff Wheel.
- This Buff Motor can quickly and violently propel a workpiece at over 80 MPH while operating causing injury and or property damage. Always wear a face shield and ANSI approved eye protection when buffing to protect face and eyes.
- The rotating Buff Wheel can quickly catch loose clothing, long hair or jewelry causing serious personal injury. Keep all loose clothing, long hair and jewelry away from operating Buff Motor.
- Rotating Buff Wheels can cause burns and abrasions if contacted by bare flesh. Do not touch rotating Buff Wheels. Always wear thick, well-fitting leather gloves and arm protection when buffing.
- A damaged Buff Wheel can disintegrate at high speed causing personal injury or property damage. If excessive vibration is felt, discontinue use immediately and disconnect tool from electrical supply. Inspect Buff Wheel or Motor for damage. Do not resume use until resolution is found.
- This Buff Motor can quickly start up when handling while plugged in to electrical supply causing serious personal injury. Always unplug Buff Motor from the electrical supply before changing Buff Wheel or performing maintenance.



# ADDITIONAL SAFETY INFORMATION



## **⚠ WARNING** INJURY HAZARD – DO NOT USE GRINDING WHEELS ON THIS BUFF MOTOR!

- This Buff Motor is designed for use only with Fabric Buff Wheels and does not have the shaft support or necessary guards to protect the operator from solid debris or shattering grinding wheels.



## **⚠ CAUTION** BURN HAZARD!

- Applying excessive pressure against a wheel while buffing can rapidly build heat in an object and cause burns and damage to the object. Do Not apply excessive pressure while buffing.



## **⚠ CAUTION**

- This Buff Motor will eject a trail of grit, fibers and debris at high speed which can injure others nearby. Keep all persons and pets away from the work area.

# SET UP FOR USE

- Place the Buff Motor on a clean, level, dust and grit free surface. The rubber feet of the cast iron Buff Motor Housing are designed to assist with stability during normal operation, however it is strongly recommended if the Buff Motor is to be operated on a bench, it should be placed securely to prevent any chance of it working its way to the edge and falling. Bolting in place or the use of C-Clamps is strongly recommended.
- If mounting to an optional Buff Stand such as Eastwood #13162, the Stand MUST be securely bolted to the floor and the Buff Motor securely bolted to the Stand.
- The Buff Motor must be operated with at least 3 ft of working room around in all directions.
- Keep power cord away from Buff Wheel. The unit is equipped with a 6' [1.8 m] long, grounded, power cord. If an extension cord is required, use 14 ga. or heavier. Do not exceed 25'.
- Buff Wheels will shed and deposit a great deal of fiber, excess buff compound and grit on floor and wall areas in the plane of the rotating wheel. Locate in an easily cleaned area capable of accepting debris.

# MOUNTING BUFF WHEELS

## #64732, 1 HP, DUAL-SPEED MOTOR

### Left Side

- Slip Spacers [E] & [F] over Arbor Shaft to the step of the Shaft (FIG 1).
- Place a Buff Wheel Support Flange [D] onto the shaft up to the spacers [E] & [F] and with the cupped surface facing outward (FIG 1).
- Push a Buff Wheel of choice (not included) over the threaded end of the Shaft up to the Buff Wheel Support Flange [D] (FIG 2).
- Add another Buff Wheel Support Flange [D] with the cupped face toward the Buff Wheel.
- Thread Special, Left-Hand Threaded Arbor Nut [B] onto Shaft threads up against the Buff Wheel Support Flange [D] (FIG 2).
- Use a wrench (not included) to snug up the Nut while holding the Buff Wheel. Another wrench (not included) may be placed around the flats at the inner surface of the Shaft to keep it from rotating if required.

### Right Side

- The Right-Side procedure is identical to the Left except for using the Standard, Right-Hand Threaded Arbor Nut [C].

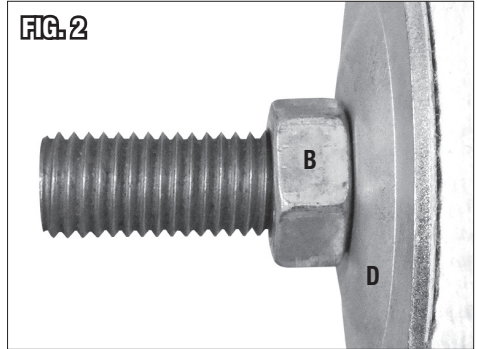
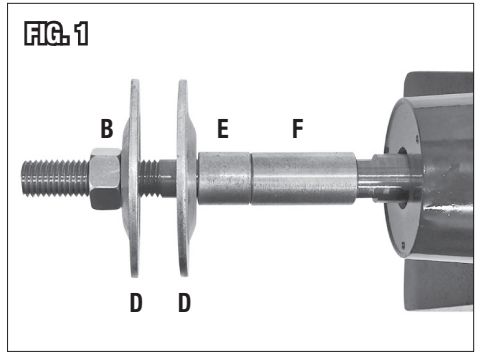

## #64733, 1/2 HP BUFF MOTOR

### Left Side

- Slip Spacer [E] over Arbor Shaft to the step of the Shaft (FIG 3).
- Place a Buff Wheel Support Flange [D] onto the shaft up to the spacer [E] and with the cupped surface facing outward. (FIG 3).
- Push a Buff Wheel of choice (not included) over the threaded end of the Shaft up to the Buff Wheel Support Flange [D] (FIG 4).
- Add another Buff Wheel Support Flange [D] with the cupped face toward the Buff Wheel.
- Thread Special, Left-Hand Threaded Arbor Nut [B] onto Shaft threads up against the Buff Wheel Support Flange [D] (FIG 4).
- Use a wrench (not included) to snug up the Nut while holding the Buff Wheel. Another wrench (not included) may be placed around the flats at the inner surface of the Shaft to keep it from rotating if required.

### Right Side

- The Right-Side procedure is identical to the Left except for using the Standard, Right-Hand Threaded Arbor Nut [C].

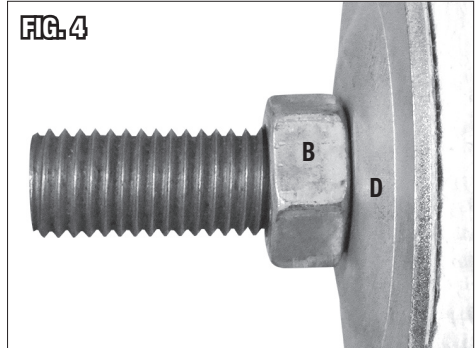
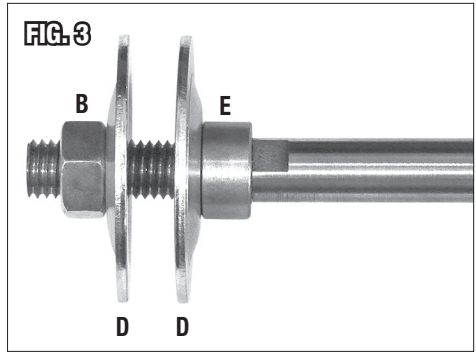



# OPERATION

## #64732, 1 HP, DUAL-SPEED MOTOR

- Check that the Rocker Switch is in the down “OFF” Position (**FIG 5**).
- Turn Rotary Switch to the Neutral “O” Position (**FIG 5**).
- Plug into a properly grounded, 15 Amp outlet.
- Turn Rotary Switch to the desired “L” [Low Speed] or “H” [High Speed] position.
- Move Rocker Switch up to the “ON” Position.
- Motor will begin to rotate. Allow approximately 10 seconds for Motor to “spool up” to operating RPM before use.

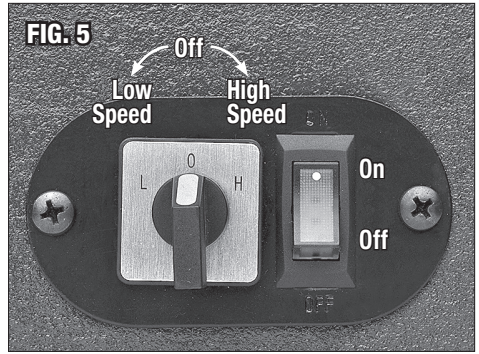

## #64733, 1/2 HP MOTOR

- Check that the Rocker Switch is in the down “OFF” Position (**FIG 6**).
- Plug into a properly grounded, 15 Amp outlet.
- Move the Rocker Switch to the up “ON” Position (**FIG 6**).
- Motor will begin to rotate. Allow approximately 10 seconds for Motor to “spool up” to operating RPM before use.



# BUFFING BASICS

## **⚠ WARNING**

Only work from the “Work Zone” at the front lower portion of the Wheel (Fig 7). Subjecting a workpiece to a point above the centerline of the Arbor Shaft (Fig 8) can quickly tear the item from the operator’s hands and propel the object at over 80 MPH with great force.

## **⚠ WARNING**

Always position workpiece edges so that the wheel is rotating “off the edge” (Fig 9). NEVER feed an edge “into” the wheel (Fig 10). Feeding an edge into a rotating wheel is extremely dangerous and will quickly and violently kick the object back at the operator causing injury and damage.

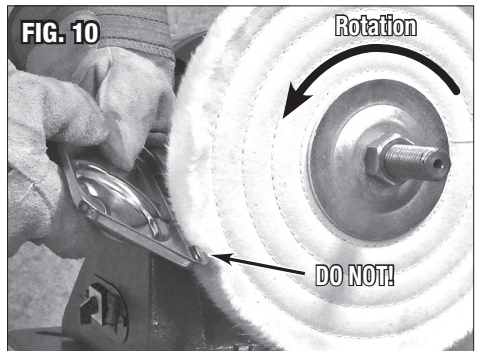
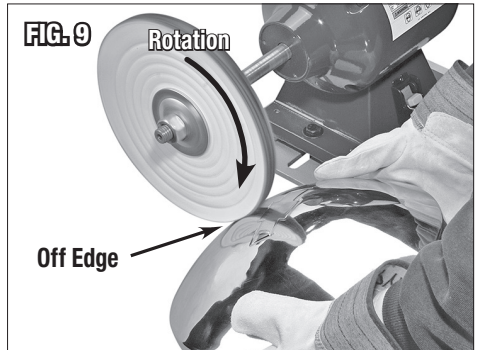
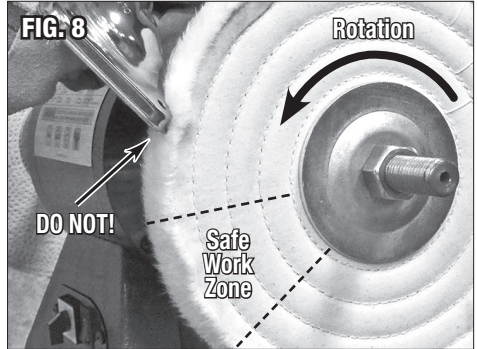
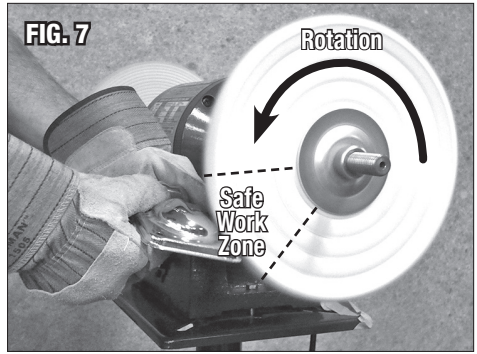

**▲ NOTICE**

**DO NOT OVERLOAD!**

The Buff Motor is designed to operate with minimal pressure against Buff Wheel and the best buffing results will always be accomplished by letting the rotating wheel do the work.

Attempts to quickly buff objects with excessive pressure will generate excessive heat which can damage the work piece, use excessive compound and rapidly wear buff wheels.

A good rule of thumb is to only apply the same amount of pressure to a rotating buff wheel as would be required to shut a drawer. If any deflection of the wheel is noticed, the pressure is too great.

**▲ NOTICE**

When buffing plated objects, always use caution not to buff through the plating.

# SELECTING BUFF WHEELS AND COMPOUND

Compounds are available in a variety of Grits to accommodate different metals and materials. In addition, Buff Wheels are offered in an array of textures ranging from soft to aggressive. Generally, a harder material will require pairing a stiffer, more aggressive Buff Wheel with a courser grit Compound. Also, as the buffing of a part continues, there is a progression of successively softer Buff Wheels and less aggressive Compound formulations.

The following chart can be used as a general guide to choosing the right Compound and Buff Wheel for the job:

<b>Buffing Wheel and Compound Pairing/Stepping Chart</b>					
<b>Materials</b>	<b>Steel, Iron, Stainless, or Other Hard Materials</b>	<b>Soft Metals; Brass, Copper, Aluminum, Zinc, Etc.</b>	<b>Chrome, Nickel, Plate</b>	<b>Solid and Plated Gold, Silver</b>	<b>Plastics</b>
<b>Step 1 – Rough</b> Compound / Buff	Emery Compound / Sisal Wheel	Tripoli, Compound/ Spiral/Ventilated Wheel	N/A	N/A	Plastic Compound, Loose or String Buff Wheel
<b>Step 2 – Intermediate</b> Compound / Buff	Stainless Compound/ Spiral or Ventilated Wheel	N/A	Stainless Compound*/ Spiral or Ventilated Buff Wheel	N/A	N/A
<b>Step 3 – Final</b> Compound / Buff	White Rouge Compound/ Loose Section Wheel	White Rouge Compound/ Loose Section Wheel	White Rouge Compound/ Loose Section Wheel	Jeweler's Rouge*/ Flannel Wheel	Plastic Compound/ String Buff Wheel
Wheel Speed – RPM	3450	3450	3450	1725/3450	1725**

\*Use Caution to avoid buffing through plating.

\*\*Avoid excessive heat build up which will destroy some plastics.

Always use a dedicated Buff Wheel for a specific compound. Example: if using Emery on a Sisal Wheel, use that Wheel exclusively with Emery Compound. Never contaminate a Buff Wheel by attempting to use another type of Compound. This can cause damage to the surface of a workpiece and ruin the Buff Wheel.

# APPLYING COMPOUND

## ⚠ NOTICE

The compound will appear to be hard and dried out which is quite normal. The compound is formulated of specifically graded abrasive in a hard-wax binder. The heat generated by contacting the rotating buff wheel melts the binder and spreads the abrasive on the wheel.

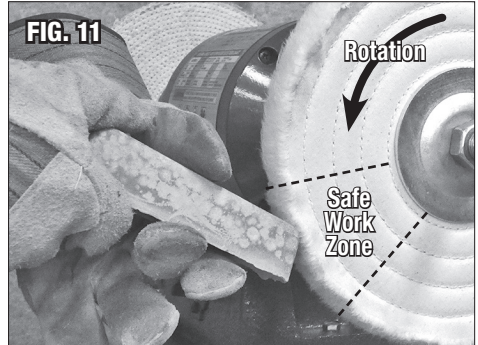

- Remove the Compound Bar from the package and holding it firmly, gently apply Compound to the “Work Zone” area of the rotating wheel (**FIG 11**). Apply sparingly, one or two seconds against the wheel every few minutes is enough. More is not better, and it is best to apply a small amount more frequently than too much at once.

# BUFFING OBJECTS

As with many skills, Buffing requires a learning curve to become proficient; however once learned, will prove to be highly satisfying.

To get started, refer to the included *Buffing & Metal Finishing Instructions & How to Guide* for an understanding of some best practices to use when buffing. Another great source of guidance is item #13304 - Eastwood Art of Buffing Instructional DVD (not included).

It is highly recommended to practice buffing on some old objects of low value and experiment with different metals Compounds and Buff Wheels. Generally, expect to spend some time and waste some product before taking on something of value.

- Before turning on the Motor, take a few moments and plan the work to be done. Take notice of all sharp edges, corners or protruding features that could snag the wheel. Be sure to plan on buffing those areas with the wheel rotating away.
- Begin in one area, let the compound work and move the object across the wheel horizontally. Never stop and hold the object against wheel. Use very light pressure and move down 1/4" after each pass until finished (**FIG 12**).
- On larger objects, divide the surface area into 1" x 2" areas and move from area to area.

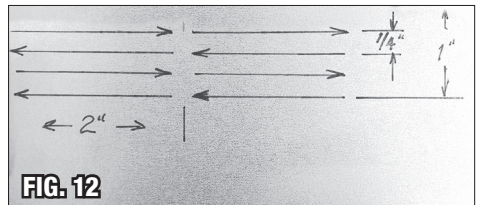

## ⚠ CAUTION

Never lose focus in keeping the edge of the object in the direction of wheel rotation and in the “Work Zone” of the Wheel (**Fig 13**).

- When done, clean the surface of the just buffed object of all compound residue and inspect. Eastwood #10194ZP, PRE Painting Prep is excellent for cleaning buffing residue as are acetone, mineral spirits or denatured alcohol. If some areas require additional attention, repeat above buffing process and check again. Numerous “clean & check” periods may need to be done to achieve the desired results.

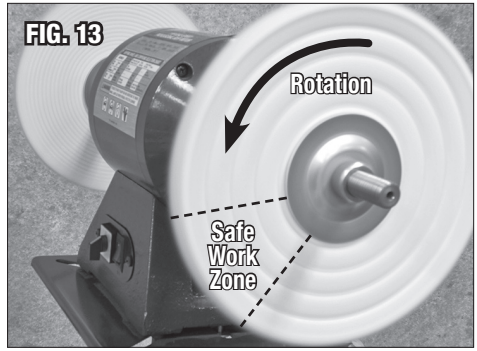

- Always clean the buffing residue on the object before progressing to the next finest Compound/Wheel combination or contamination of the softer wheel will occur.
- When stepping to the next finest Compound/Wheel combination, unplug the Buff Motor and change to the next Wheel.

**⚠ CAUTION**

**Never attempt to buff concave, deeply recessed or inside surfaces where there is a danger of catching and edge on the rotating Wheel.**



# CLEANING BUFF WHEELS

After use, all Buff Wheels will build up an accumulation of compound and metal particles. When this occurs, it reduces the overall effectiveness and must be removed.

Use an Eastwood #13120 Buff Rake. To do so:

- Gripping it firmly by the handles, lightly press it into the rotating Wheel in “The Work Zone” of the Wheel in 10 second increments until the bulk of the material is removed (**FIG 16**).
- The Buff Rake will also true an out of round wheel. This is done by first cleaning the wheel then holding the Rake at the edge of the Wheel and allowing just the high spots to contact the Rake. As the “High Spot” fibers are removed, the Wheel will return to proper roundness.

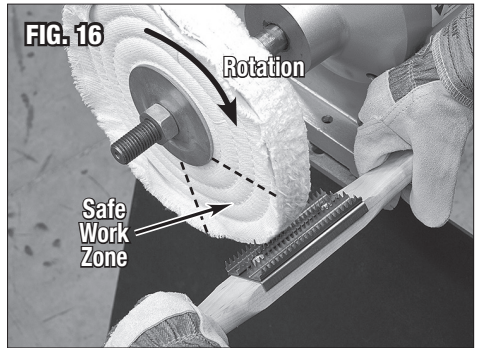

# STORING BUFF MOTOR

- Unplug from power source.
- Wrap cord securely around Buff Motor.
- Store in a clean, dry, dampness free area preferably covered with plastic sheeting.

# MAINTENANCE

The following maintenance should be performed before each use:

- Check tightness of all Motor and Wheel mounting hardware.
- Check Motor controls operation.
- Inspect Buff Wheel for tears, damage or premature wear.

# TROUBLESHOOTING

## Motor Performance Issues

PROBLEM	CAUSE	CORRECTION
<b>Does Not Run When Switch is Turned On</b>	No power to Buff Motor	Check 120 VAC input plug connection
		Check for tripped circuit breaker. The Buff Motor operates on a 15 Amp Minimum circuit.
<b>Motor Runs Too Slow/ Develops Low Power</b>	Excessive voltage drop due to under-sized and or too long of an extension cord used	Extension cords not recommended. If necessary, use only 14 Gauge or larger cord and limit length to 25'.
	Excessive voltage drop due to local power company voltage supply.	Use at another location or at a time when voltage is higher.
<b>Excessive Noise and/or Vibration</b>	Buff Wheel likely torn or damaged. <b>WARNING: This is an extremely unsafe condition!</b>	Discontinue use and replace Buff Wheel.
<b>Motor Overheats</b>	Excessive pressure being applied to Wheel while Buffing	Allow Wheel to work by rotation alone. Do Not Force.



# TROUBLESHOOTING

PROBLEM	CAUSE	CORRECTION
<b>Edge of Buff Wheel Turns Black</b>	This is a normal result of Buffing	Occasionally clean Wheel with a Buff Rake (Eastwood #13120).
<b>Metallic Buildup on Wheel Edge</b>	This is normal and occurs with softer metals such as aluminum or brass	Occasionally clean Wheel with a Buff Rake (Eastwood #13120).
<b>Black Streaks Appearing on Work Piece Surface</b>	Indication of excessive compound application	Use less compound. Apply compound often but in very small amounts.
<b>Buff Motor Does Not Effectively Buff Workpiece</b>	Wheel and compound combination too soft	Select a courser buff wheel and compound.
		Alter direction the workpiece is being passed across the face of the Wheel.
<b>Workpiece Is "Bouncing" or "Shuddering" Against the Wheel</b>	To much pressure being applied against Wheel	Allow work piece to only lightly contact Wheel.
	Wheel out of round or damaged	Turn off Buffer and inspect Wheel. Dress Wheel with Buff Rake (Eastwood # 13120) or replace Wheel if torn or damaged.

# TROUBLESHOOTING

PROBLEM	CAUSE	CORRECTION
<b>Wheel Is Wearing Too Quickly</b>	To much pressure being applied against Wheel	Allow work piece to only lightly contact Wheel.
<b>Wheel Is Shedding An Excessive Amount of Fiber</b>	It is normal for a Wheel to shed some excess fiber at first use however that will sharply decrease	Allow wheel to shed initial loose fibers.
	To much pressure being applied against Wheel	Allow work piece to only lightly contact Wheel.

# BUFF COMPOUND SELECTION

## #32030 EMERY (Dark Gray)

For fast cutting on iron, steel and other hard metals to remove scratches, rust, corrosion burrs etc. Use with Sisal wheels. Do Not use on gold or silver.

## #32031 STAINLESS (Light Gray)

For buffing stainless and other steels, chromium, nickel plate and some harder plastics. Use with Spiral or Ventilated buffs. Do Not use on gold or silver.

## #32032 TRIPOLI (Brown)

For buffing all base metals. Use on brass, aluminum, pewter, copper etc. Also plated surfaces. Use with Spiral or Ventilated wheels. Do Not use on gold or silver.

## #32033 WHITE ROUGE (White)

For final coloring on metal. Produces a brilliant high shine. Removes light scratches. Use with Loose or Canton Flannel buff wheels.

## #32034 JEWELERS ROUGE (Red)

For the highest finish on gold, silver and other precious metals. Use with Canton Flannel or Felt buff wheels for best results.

## #32035 PLASTIC (Blue)

For cut and coloring on hard plastics. Do Not use on soft or low melting point plastics like polyethylene. For cut-down, use Spiral Sewn buff wheel. For final high luster, use Flannel or String buffs.

# BUFF WHEELS

- #13061 10" Sisal Buffing Wheel for 3/4" arbor
- #13060 8" Sisal Buffing Wheel for 5/8" arbor
- #13038 10" Spiral Sewn Buffing Wheel for 3/4" arbor
- #13033 8" Spiral Sewn Buffing Wheel for 5/8" arbor
- #13046 10" Canton Flannel Buffing Wheel for 3/4" arbor
- #13058 8" Canton Flannel Buffing Wheel for 5/8" arbor
- #13041 10" Loose Section Buffing Wheel for 3/4" arbor
- #13044 8" Loose Section Buffing Wheel for 5/8" arbor
- #13030 10" Cotton String Buffing Wheel for 3/4" arbor

# ADDITIONAL ITEMS

- #13120 Buff Rake
- #31573 Rockwood Clear Face Shield
- #21296, 21297 Tilman TruFit Work Gloves
- #13304 Eastwood Art of Buffing Instructional DVD

---

**If you have any questions about the use of this product, please contact**

The Eastwood Technical Assistance Service Department: 800.343.9353 >> email: [tech@eastwood.com](mailto:tech@eastwood.com)

PDF version of this manual is available at [eastwood.com](http://eastwood.com)

The Eastwood Company 263 Shoemaker Road, Pottstown, PA 19464, USA

800.343.9353 [eastwood.com](http://eastwood.com)