

Eastwood®

EW# 51118 - 100 POUND ABRASIVE BLASTER OPERATING MANUAL

Model # EW 51118



The EASTWOOD Company
263 Shoemaker Road
Pottstown, PA 19464
800-345-1178 • Fax 610-323-6269
www.eastwood.com • E-mail: techelp@eastwood.com

WARRANTY

This product has a one year warranty covering any manufacturing defects. Despite our strict quality control standards implemented during our manufacturing process, sometimes a product gets shipped that does not meet our specifications. If you have a product that does not work correctly within 30 days of your purchase, send the product and the original receipt to the Eastwood Company for credit or replacement.

Before returning any product, you must contact the Eastwood Company at 800-345-1178 to acquire a Return Authorization Number.

When sending your product you must include:

1. A copy of the dated receipt showing the original purchase,
2. Your full name, street address and telephone number.

Please ship to:

The Eastwood Company
263 Shoemaker Rd.
Pottstown, PA 19464
ATTN: Warranty Return

We will examine the product. If the problem is due to a manufacturing defect, we will repair or replace the product at no charge and return it to you postage or UPS paid. If the problem is due to misuse, abuse, user modification or it is out of warranty, we will contact you with a repair estimate and ask for a credit card number for payment. After the product has been repaired, it will be returned via postage or UPS paid.

⚠ WARNING: Pressure blasters and blast cabinets emit abrasive particles under high pressure. Adequate respiratory, eye, and body protection must be utilized at all times during product operation. Inhalation of silica-based blast media particles have been known to cause cancer and other deadly diseases and must be avoided. Always wear NIOSH-approved respiratory protection when operating this equipment.

READ ALL INSTRUCTIONS BEFORE OPERATING

SAVE THESE INSTRUCTIONS

Thank you for purchasing an Eastwood 100 lbs Abrasive Blaster. Before attempting to operate your new blaster, please read these instructions thoroughly. You will need these instructions for the safety warnings, precautions, assembly, operation, maintenance procedures, parts list and diagrams. Keep your invoice with these instructions. Write the invoice number on the inside of this front cover. Keep the instructions and invoice in a safe, dry place for future reference.

WARNING: The warnings, cautions and instructions discussed in this instruction manual cannot cover all possible conditions or situations that could occur. It must be understood by the operator that common sense and caution are factors which cannot be built into this product, but must be supplied by the operator.

TABLE OF CONTENTS

Description	Page #
Warranty	2
Specifications	2
Safety rules	2-3
Assembly	3
Operation	4
Maintenance	4
Abrasive Selection	5
Parts Diagram	7

SPECIFICATIONS

Tank Volume	10 gallons / 100 pounds
Hose Length	8 ft. x 1/2" i.d.
Working Pressure	60-125 psi
Air Consumption	6-25 cfm
Overall Dimensions	11" x 17" x 34"
Weight	41 lbs

SAFETY RULES

1. Do not use any sand or silica based abrasives with this tool. Silica based abrasives have been linked to severe respiratory disease.
2. Read this manual carefully. Learn the tool's applications and limitations, as well as potential hazards specific to it.
3. Do not expose tool to moisture. Don't use this tool in damp or wet locations. Keep out of rain.

4. Keep work area clean and well lit. Cluttered or dark work areas invite accidents.
5. Keep children away. All children should be kept away from the work area. Never let a child operate the abrasive blaster.
6. Do not operate this tool if under the influence of alcohol or drugs. Read warning labels on prescriptions to determine if your judgment or reflexes are impaired while taking drugs. If there is any doubt, do not attempt to operate.
7. Use safety equipment. Eye protection should be worn at all times when operating this tool. Use ANSI approved safety glasses. Everyday eyeglasses are NOT safety glasses. NIOSH-approved respiratory protection, non-skid safety shoes, blast hood, hard hat, and hearing protection should be used in appropriate conditions.
8. Wear proper apparel. Loose clothing, gloves, neckties, rings, bracelets, or other jewelry may present a potential hazard when operating this tool. Please keep all apparel clear of the tool.
9. Don't overreach. Keep proper footing and balance at all times when operating this product.
10. Always disconnect the tool from air supply and release pressure from the tank before making any adjustments, storing, servicing, or changing accessories. Such preventative safety measures reduce the risk of starting the tool accidentally.
11. Use clamps or other practical means to secure and support the work piece to a stable platform. Holding the work by hand or against your body may lead to a loss of control.
12. Do not force tool. Use the correct tool for your application. The correct tool will do the job better and safer at the rate for which it was designed.
13. Check for damage regularly. If any part of the tool is damaged it should be carefully inspected to make sure that it can perform its' intended function correctly. If in doubt, the part should be repaired. Refer all servicing to a qualified technician. Consult Eastwood for advice.
14. Keep away from flammables. Do not attempt to operate this tool near flammable materials or combustibles. Failure to comply may cause serious injury or death.
15. Always check to make sure that the trigger is not on before connecting blaster to air supply. Blaster may cause damage to property or person if connected to air while the dead man valve is open.
16. Store idle tools out of the reach of children and untrained persons. Tools may be dangerous in the hands of untrained users.
17. Drain water trap periodically during use. Do not allow moisture to fill more than 1/2 the water trap bowl. Do not leave water standing in water trap when done with work.

18. Do not allow abrasive blaster to sit pressurized while unattended or not in use.
19. Make sure all equipment is rated to the appropriate capacity. Make sure regulator is set no higher than 125 psi.
20. Periodically check the abrasive medium delivery equipment. Valves, hoses and nozzles that carry the abrasive medium after it leaves the pressure tank are subjected to the abrasive blasting action so they will wear out more quickly than other components.
21. Release the air pressure in the tank before opening. See "Releasing Pressure from the Tank" section. Make sure pressure gauge reads "0" before opening the tank. Do not attempt any maintenance on the abrasive blaster until the pressure gauge reads "0", and it has been disconnected from air supply.
22. Maintain correct air pressure when working. Do not allow pressure to exceed 125 psi. If the safety valve does not release excess air pressure, stop all work and release pressure from the tank (see "Releasing Pressure from the Tank" section).

AIR/ABRASIVE SUPPLY REQUIREMENTS

Hose ID	Hose L	Nozzle ID	Compressor HP	CFM@ 125 psi	Abrasive Use/Hr
3/8	50 ft	2	2	6	30 lbs.
3/8	25 ft.	2.5	4	12	80 lbs.
1/2	50 ft.	3	7	20	120 lbs.
1-1/2	15 ft.	3.5	10	25	150 lbs.

ASSEMBLY

Note: Use teflon pipe tape on all threaded joints. Make sure all joints are securely tightened.

Abrasive Safety Trigger Assembly (Figure 1)

1. Locate the Abrasive Safety Trigger, the Abrasive Hose (24) and the two Hose Clamps (23).
2. Slide one Hose Clamp onto each end of the Abrasive Hose. Do not tighten yet.
3. Slide one end of the Abrasive Hose onto the Abrasive Safety Trigger Hose Adaptor (49) and firmly tighten Hose Clamp.
4. Slide the other end of the Abrasive hose onto the Abrasive Outlet Manifold (22) and firmly tighten Hose Clamp.

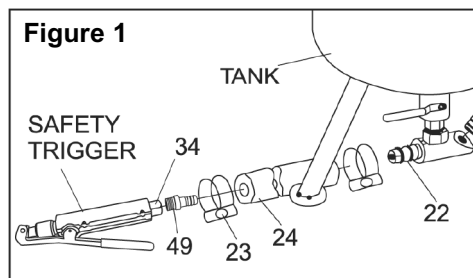

Handlebars, Wheels and Foot Assembly (Figure 2)

1. Locate the two Handle Bars (06), the two Handle Grips (07), the four Screws (08), the four nuts (09), and the four Washers (50).
2. Lay the Abrasive Blast Tank on a flat level surface (such as a workbench or table top), with the handlebar mounting brackets facing up.
3. If Handle Grips are not already installed on the Handle Bars, slide them onto the Handle Bars, with the finger holds towards the bottom of each Handle Bar.
4. Handle Bars are labeled "LEFT" and "RIGHT." Align the holes in the left Handle Bar with the Handle Bar Mounting Brackets on the left side of Blast Tank.
5. Place a Washer (50) onto each of the four handle bar mounting Screws (08). Insert a Screw through each of the holes in Handle Bar and Handle Bar Mounting Brackets.
6. Place a nut onto each of the Screws and firmly tighten in place with a wrench.
7. Repeat steps 4 – 6 for right Handle Bar.
8. Locate the two Wheels (02), the three Cotter Pins (03), the Wheel Axle (05), four Wheel Washers (51), and the Front Foot (04).
9. Slide the Wheel Axle (05) through the axle holes located at the bottom of the Handle Bars.
10. Slide a Wheel Washer (51) onto each end of the wheel axle.
11. Place a Wheel (02) onto each end of the Wheel Axle then slide a Wheel Washer onto the axle.
12. Insert a Cotter Pin(03) through the holes in each end of the Wheel Axle and bend them so the wheels cannot slide off the Wheel Axle.
13. Roll Abrasive Blast Tank over so that Handle Bars are now facing down.
14. Align the holes of the Front Foot (04) with the

holes in the foot mount on the front side of the Blast Tank.

15. Insert a Cotter Pin (03) through the holes and bend it so the Front Foot cannot slide off the foot mount.

Pressure Gauge

1. Locate the Pressure Gauge (15).
2. Wrap the threads of the Pressure Gauge with teflon tape.
3. Insert the treaded end of the Pressure Gauge into the Intake Manifold (14) and firmly tighten in place with an 11mm wrench.

OPERATION

⚠ Warning: Always wear your blast hood, NIOSH-approved respiratory protection, ANSI-approved safety glasses and heavy duty canvas gloves when operating the abrasive blaster.

⚠ Warning: Before operating your abrasive blaster, inspect each connection, double checking to make sure that all are tight and properly sealed.

⚠ WARNING: THIS MACHINE IS NOT INTENDED FOR USE WITH SILICA BASED ABRASIVES. SILICA BASED ABRASIVES HAVE BEEN LINKED TO SEVERE RESPIRATORY DISEASE. ALWAYS USE SILICA SUBSTITUTES (SUCH AS EASTWOOD 22019 SILICON CARBIDE, 13792 ALUMINUM OXIDE, OR 13780 GROUND GLASS) WHEN ABRASIVE BLASTING!

Loading Abrasive

1. Check to make sure the abrasive is dry and clean so that it does not clog the unit.
2. Close the brass Air Supply Valve (18) by turning it to the vertical position.
3. To release the pressure from the Tank, press Safety Trigger until air stops.
4. Make sure the Pressure Gauge (15) reads "0".
5. Remove the Filler Cap (12).
6. Using the Funnel (29), pour the selected abrasive media into the tank (1). Do not fill the tank more than 3/4 full. If humidity in your region is 90% or more, only fill the tank half full and check the water trap (17) more frequently.
7. Close the Filler Cap securely, assuring o-ring is in place.

Note: Place your air compressor in another room to prevent damage to it.

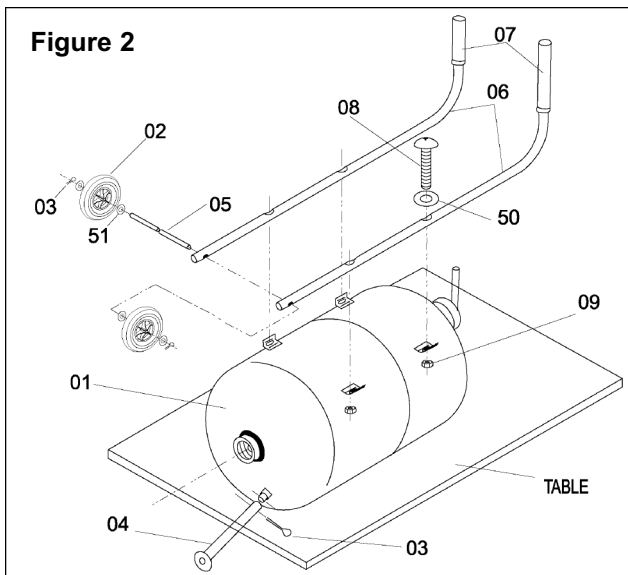

To Start Abrasive Blasting

Note: Start with all valves in the closed position. Following the instructions below will help prevent the formation of clogs in the abrasive hose, outlet manifold and the safety trigger. (refer to Parts Diagram pg. 7)

1. Connect air compressor to the Inlet Connector (19).
2. Start compressor and open Air Supply Valve (18).
3. Open Throttling Valve (18A).
4. Check for leaks at the Filler Cap and along all hoses and fittings as the system pressurizes. If leaks are observed, release the pressure from the tank and repair immediately.
5. Point Safety Trigger in a safe direction away from people, pets or anything around you that may be damaged by direct or indirect abrasive spray.
6. Press and hold Safety Trigger until air is flowing through the trigger.
7. With the Safety Trigger open, slowly open the Abrasive Control Valve (18B) until abrasive material begins to flow out of the Safety Trigger.
8. Adjust the Abrasive Control Valve (18B) until the desired amount of abrasive material is flowing through the Safety Trigger.
9. Begin blasting.

To Stop Blasting

1. While continuing to press and hold the Safety Trigger, turn the Abrasive Control Valve (18B) to the closed position (this is to prevent any clogging.)
2. When you notice only air (no abrasive) is coming out of the Safety Trigger, you can stop the air flow by releasing the trigger. This ensures a clean and clog-free manifold, hose, and safety trigger.

Releasing Pressure from the Tank

1. When you are finished blasting, point Safety Trigger in a safe direction away from people, pets or anything around you that may be damaged by direct or indirect abrasive spray.
2. Press and hold the Safety Trigger to expel any remaining abrasive material from the Abrasive Hose (24).
3. Close the Abrasive Control Valve (18B).
4. Release pressure on the Safety Trigger.
5. Close the Throttling Valve (18A) and the Air Supply Valve (18).
6. Disconnect air supply hose from abrasive blaster.
7. Press the Safety Trigger until air stops flowing and Pressure Gauge (15) reads "0".

MAINTENANCE

1. Keep your abrasive blaster clean, and protect it from damage.
2. Release pressure from the tank after each use.
3. When initially pressurizing, check for leaks at the tank top and at all hoses and fittings. Leaking joints may be repaired by replacing worn or damaged parts and using teflon tape at joints.
4. Check for worn abrasive hose and fittings. The Abrasive Control Valve, manifold, and all parts after the abrasive is ejected from the tank are subject to rapid wear due to the flow of abrasive. Watch especially for leaks, blistering, bulging or thinness of the hose. Replace any parts which appear worn.

ABRASIVE SELECTION

The kind of abrasive you choose will greatly influence the amount of time needed to clean a given surface area. Abrasive materials include glass beads, aluminum oxide, and others. For best results, use 80 grit abrasive or finer. Do not exceed 80 grit media size.

- Make sure that the abrasive you use is thoroughly dry. Damp abrasive can cause clogging of your abrasive blaster.
- While you may reuse abrasive, remember that abrasive does wear out. After use, abrasive becomes smoother and rounder, thus reducing abrasive effectiveness.
- Reusing abrasive may also cause clogging due to debris contained in the mixture from prior use.

Abrasive Flow Adjustment

- Choose a larger nozzle for a broader spray pattern. Choose a smaller nozzle for more focused abrasive blasting.
- Adjust air pressure with the Brass Throttling Valve (18A). Adjust abrasive flow with Abrasive Control Valve (18B).
- Watch for abrasive clogging. Release pressure from the tank if necessary and replace the abrasive with drier or cleaner abrasive.

Safety and Health Considerations

⚠ WARNING: THIS MACHINE IS NOT INTENDED FOR USE WITH SILICA BASED ABRASIVES. SILICA BASED ABRASIVES HAVE BEEN LINKED TO SEVERE RESPIRATORY DISEASE. ALWAYS USE SILICA SUBSTITUTES (SUCH AS EASTWOOD 22019 SILICON CARBIDE, 13792 ALUMINUM OXIDE, OR 13780 GROUND GLASS) WHEN ABRASIVE BLASTING!

- Before opening tank make sure that it is not pressurized. Be sure that the gauge reads “0”. If the gauge does not read “0”, release pressure from the tank (see “Releasing Pressure from the Tank” section).
- Disconnect the compressor before opening tank.
- Protect yourself and those around you from “over-spray”. Remember that your portable abrasive blaster is shooting a powerful spray of abrasive material. Do not point it at yourself or anyone around you.
- Wear protective clothing including hood (30), safety eye covering, and heavy gloves when using this abrasive blaster.
- Wear NIOSH-approved respiratory protection when using this tool. Blasting creates a cloud of abrasive material and debris which is dangerous to inhale.

- Remove, cover or protect anything around you that might be damaged from direct or indirect contact with the abrasive spray or particles. Nothing subject to contamination damage or with a fine surface should be near your abrasive blaster.

Caution

Pay particular attention to the Abrasive Hose (24), the Abrasive Control Valve (18B), and the Nozzles (37) as they will wear out much more quickly than the other pieces.

The Abrasive Hose needs to be replaced immediately if its side walls develop leaks or show blisters in the surface. Do not use if any of these problems are present.

