

Note: All joints to be perimeter welded.

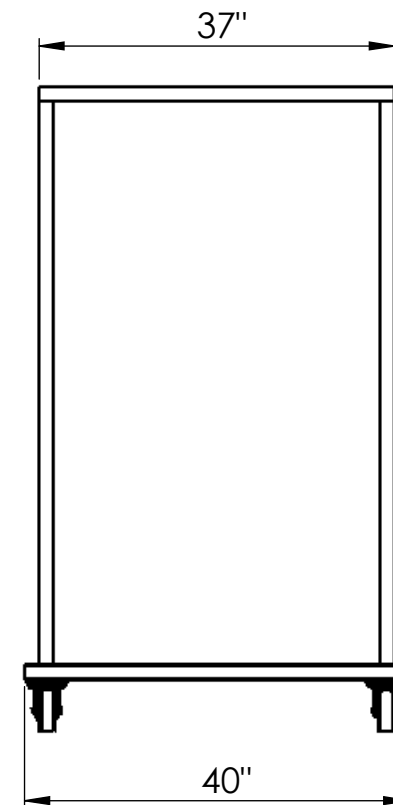

MATERIAL Mild Steel	FINISH Raw	WEIGHT	PART NO.
UNLESS OTHERWISE SPECIFIED: DIMENSIONS ARE IN INCHES		<b>The Eastwood Company</b> 263 Shoemaker Rd. Pottstown, PA. 19464 www.eastwood.com	
		<b>Powder Coat Oven</b> <b>PARTS RACK</b>	
SIZE <b>B</b>	DRAWN NC	DWG. NO.	
SCALE: 1:20		DATE: 20/07/28	REV 1

REV	INIT	DATE	DESCRIPTION
1	NC	20/07/28	Drawn

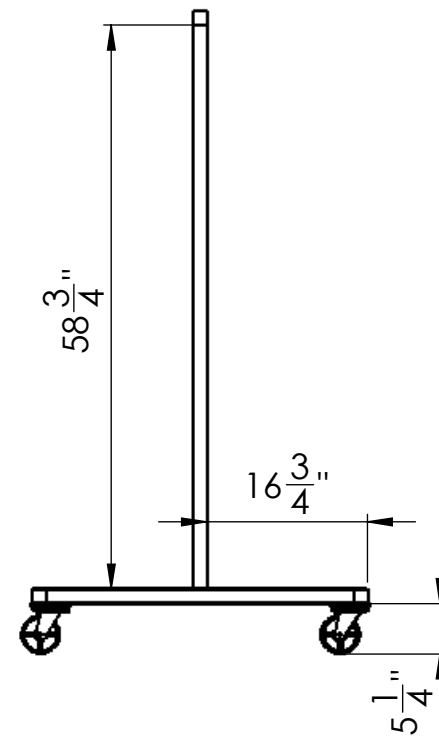
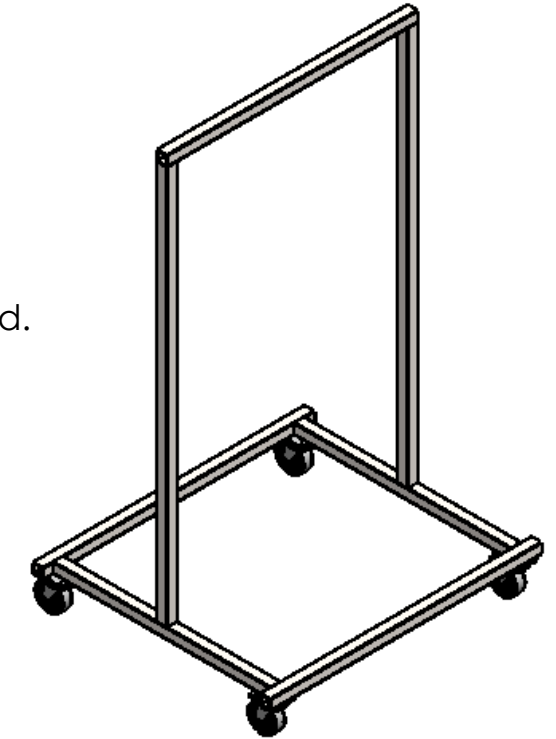
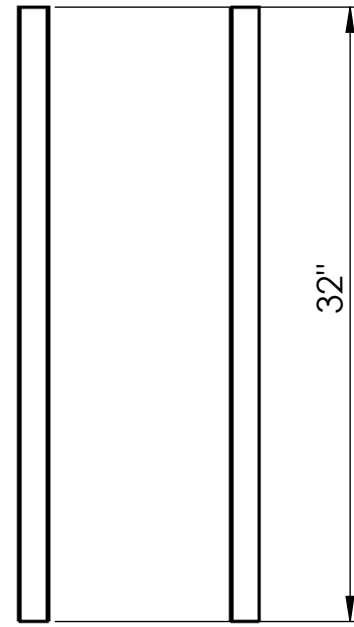
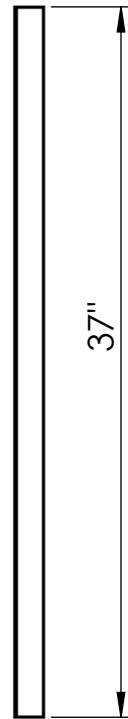
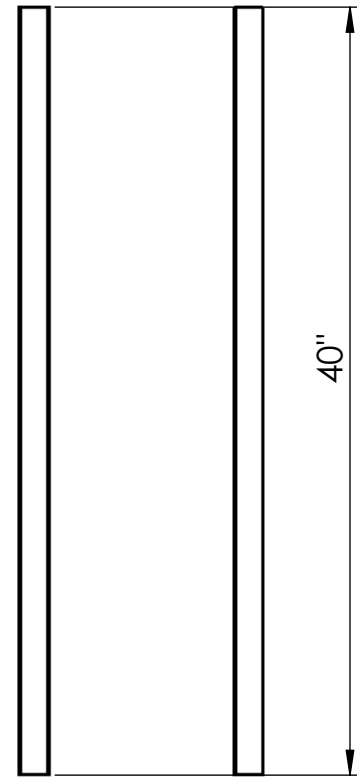
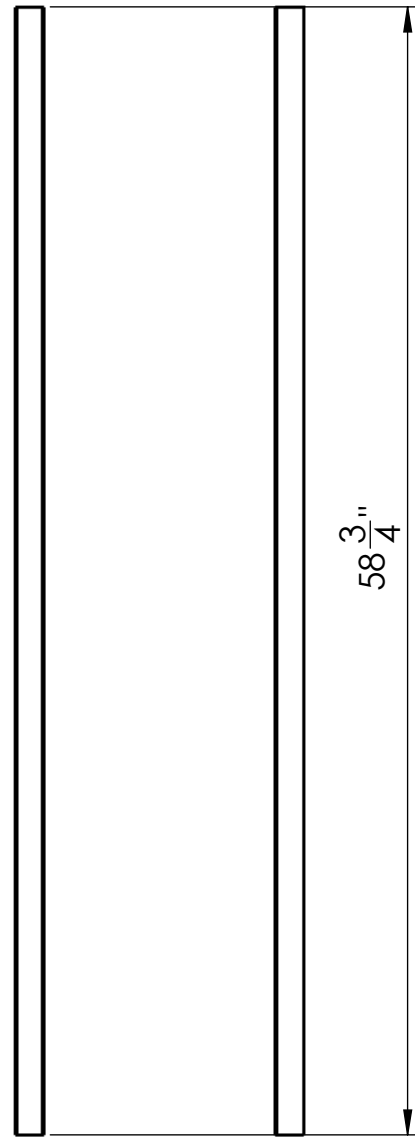

REV	INIT	DATE	DESCRIPTION
1	NC	20/07/28	Drawn

MATERIAL Mid Steel	FINISH Raw	WEIGHT	PART NO.
UNLESS OTHERWISE SPECIFIED: DIMENSIONS ARE IN INCHES		<b>The Eastwood Company</b> 263 Shoemaker Rd. Pottstown, PA. 19464 www.eastwood.com	
<b>HOTCOAT POWDER COATING OVEN PARTS RACK</b>			
SIZE <b>B</b>	DRAWN NC	DWG. NO.	
SCALE: 1:10		DATE: 20/07/28	REV 1